

Canada's  
Amateur Radio  
Magazine

La Revue des  
Radioamateurs  
Canadiens

# THE CANADIAN AMATEUR

JANUARY / FEBRUARY 2024 – JANVIER / FÉVRIER 2024



Publications Mail Agreement # 40028682 Registration # 09866

**TAP INTO OUR GENIUS SOLUTIONS AND MAKE EVERYTHING AROUND YOU FEEL SMARTER.**

Genius products are engineered to work so well in tandem, expanding your station's ability to deliver exceptional experiences and exponential performance increases. Add a Power Genius XL and get the only legal-limit SO2R/Multi-Single capable HF/6M amplifier on the market. Add a Tuner Genius XL and gain not only super-fast, legal-limit impedance matching on antennas with up to 10:1 SWR but then pick up 70dB of port isolation for seamless SO2R operation. Add an Antenna Genius and enjoy frequency-driven contest-class SO2R antenna switching and super-station automation capabilities. With integration this easy our Genius Solutions help you realize the potential of your station, making you genius-level smart along the way. Learn more at [FlexRadio.com](http://FlexRadio.com)



Find Everywhere

# IT'S TOTALLY NORMAL TO SUDDENLY FEEL LIKE THE SMARTEST PERSON ON THE PLANET.



▶ SCAN TO SEE OUR PRODUCT BROCHURE



GENIUS SOLUTIONS INCLUDE

▶ POWER GENIUS XL

▶ TUNER GENIUS XL

▶ ANTENNA GENIUS

# TCA

The Canadian Amateur

# Canada's Amateur Radio Magazine La Revue des Radioamateurs Canadiens

Volume 52 Number 1 – [tcamag@yahoo.ca](mailto:tcamag@yahoo.ca) | [marcom.rac.ca](http://marcom.rac.ca) – W: <https://www.rac.ca/tca/>

January / Janvier /  
February / Février  
2024

### Editor / Rédacteur en chef

Alan Griffin  
Email: [tcamag@yahoo.ca](mailto:tcamag@yahoo.ca)

### Advisors / Conseillers

Dave Green, VE3TLY  
Norm Rashleigh, VE3LC  
Richard Ferch, VE3KI  
Ken Grant, VE3FIT  
Mike Kelly, VE3FFK

### Translation / Traduction

Jacques Roland, VA3DLZ

### Technical Diagrams / Schémas techniques

Stan Smith, VE3DDX

### Advertising Department:

Rate sheet:  
<https://www.rac.ca/tca/>  
Contact: [marcom@rac.ca](mailto:marcom@rac.ca)

The Canadian Amateur is published by Radio Amateurs of Canada Inc. / The Canadian Amateur est publié par la société Radio Amateurs du Canada Inc.

Indexed in the Canadian Periodical Index / Enregistré à l'Index des publications canadiennes : ISSN 0834-3977

Publications Mail Agreement / Accord de publications diffusées #40028682. Registration / matricule #09866

The Canadian Amateur  
720 Belfast Road,  
Suite / Bureau 217  
Ottawa, ON, Canada  
K1G 0Z5  
613-244-4367;  
1-877-273-8304  
[tcamag@yahoo.ca](mailto:tcamag@yahoo.ca)  
<https://www.rac.ca/>

Printed in Canada by St. Joseph Communications  
Ottawa, ON, Canada  
Imprimé au Canada sur les presses de St. Joseph Communications  
Ottawa, ON, Canada

Return Undeliverable Canadian Addresses to Circulation Department:  
217-720 Belfast Road  
Ottawa, ON K1G 0Z5

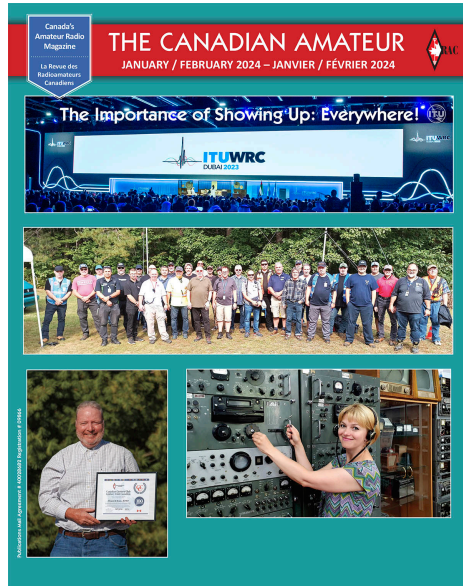

"Le 23 septembre, la Fédération des clubs radioamateurs du Québec (RAQ) a été représentée au Rendez-vous annuel des Bénévoles de l'ASCQ (Association de sécurité civile du Québec) 2023, tenu dans la ville de Contrecoeur, au nord-est de Montréal. – see pages 46-47

On September 23, the Fédération des clubs radioamateurs du Québec (RAQ) was present at the annual Quebec Civil Security Association Benevolents Gathering event ("Rendez-Vous des Bénévoles ASCQ 2023") in the town of Contrecoeur northeast of Montréal. – see pages 46-47

"The World Radiocommunication Conference 2023 (WRC-23) was held in Dubai, United Arab Emirates from November 20 to December 15 and brought governments together for negotiations on the allocation of radio-frequency spectrum." – see pages 26-28

My radio journey to Siberia began in the Urals at Yekaterinburg, right on the border of Europe and Asia. There is a special sign installed there, symbolizing this line between the continents. – see pages 32-33

"A very special mention goes out to Steven W. Hines, N2PQJ, for being the first recipient of our new Canadian Century Club award!" – see page 63

**Articles Wanted:** We would love to receive your articles – both technical and non-technical. Please send them to the TCA Editor at [tcamag@yahoo.ca](mailto:tcamag@yahoo.ca). The deadlines for the next issues of TCA are January 15 and March 15.

## National & International

RAC National Executive and Board of Directors.....	4
A Message from the President / Un Message du Président .....	5
Former RAC President Daniel Lamoureux, VE2KA SK.....	6
L'ancien président de RAC Daniel Lamoureux, VE2KA SK.....	6
Nouveau directeur du Québec/ New Quebec Director.....	7
New Consolidated QSL Manager.....	7
RAC Scholarships 2023, AI Eros, VE4ZB.....	12
RAC Regulatory Roundup, Dave Goodwin, VE3KG.....	24
World Radiocommunication Conference 2023 (WRC-23) – Paul Coverdale, VE3ICV and ITU News .....	26-28
World Amateur Radio Day.....	31
New Section Manager: Ian Clarke, VE7KCP .....	41

## Technical

DXCC in 40 Days with 4 watts! – Rick Williams, VE7TK.....	14
Amateur Radio Satellites – Keith Baker, VA3KSF .....	16
QUA – A Topical Digest – Allen Wootton, VY1KX .....	20
A "Light-Touch" Push-to-Talk Switch for Boom Mic Desktop Operation – Don Dorward, VA3DDN.....	30

Radio Magic – Robert C. Mazur, VA3ROM.....see next TCA

## Departments

TCA Advertising Index.....	2
RAC QSL Bureau System .....	3
Silent Keys.....	3
Defence of Amateur Radio Fund (DARF).....	11
RAC Membership   Adhésion de RAC.....	34-36
Coming Events .....	57

For RAC Membership Inquiries and Change of Address please contact RAC HQ at: [rachq@rac.ca](mailto:rachq@rac.ca)

# Operating

Six Metres and Down – Dana Shtun, VE3DS ..... 8

RAC Scholarships 2023 – Al Eros, VE4ZB ..... 12

Youth On The Air Camp (YOTA) 2024 Returns to Canada ..... 13

RAC Regulatory Roundup – Dave Goodwin, VE3KG ..... 24

“My Siberian DXpedition” – Raisa Skrynnikova, R1BIG/OH7BG/VO1BIG ..... 32

Message from the RAC Community Services Officer – Jason Tremblay, VE3JXT.....37

How to Initiate a local Emergency Management Volunteer Program – Grant Durfey, Emergency Management Program Specialist.....37

New Ontario Golden Horseshoe Section Manager: Ian Clarke, VE7KCP.....41

Community and Emergency Service Reports (ACS/ARES) ..... 42-48

RAC Field Organization Reports / National Traffic System Net Reports.....48

The Sports Page – The Canadian Contest Scene: Tom Haavisto, VE3CX.....49

Contest Calendar for January, February and Early March.....50

World Radiosport Team Championship 2022 .....50

The Club Corner / “Bits and Pieces...” – Phil Boucher, VE3BOC .....56

Celebrating HMCS Haida’s 80th Anniversary – Jerry Proc, VE3FAB.....57

Coming Events (Hamfests and Fleamarkets).....57

My Evolving Journey in Amateur Radio – Cal DiFalco, VA3CDV .....58

GOTA Success at Field Day – Larry Bloom, VE7LXB .....58

Celebrating 90 Years of Halifax Amateur Radio Club – John Bignell, VE1JMB.....59

Roaming Up North (VY1RST, KL7RST and more) – John Reisenauer, KL7JR.....61

The RAC Challenge and Operating Awards – Ante Laurijssen, VA2BBW ..... 62-63

**Articles Wanted:** We would love to receive your articles – both technical and non-technical. Please send them to the TCA Editor at [tcamag@yahoo.ca](mailto:tcamag@yahoo.ca). The deadlines for the next issues of TCA are January 15 and March 15.

## Please Support our Advertisers

Amateur Radio Operators of Canada ..... 31

Coax Publications Inc Study Guides ..... 19, 29

Degen Designs ..... 33

FlexRadio ..... inside front cover

Hammond Manufacturing / Peter W. Dahl Co. .... 39

Hamstudy.com + Study Guides..... 29

HC MacFarlane Electronics..... 57

Premier Communications..... 11

Radioworld .....28, outside back cover

The Personal Home & Auto Group Insurance..... 64

The Canadian Amateur is published in Canada six times per year to provide Radio Amateurs, those interested in radio communications and electronics, and the general public with information related to the science of telecommunications.

Articles, reviews, letters, features, suggestions, photographs and essays are welcomed. Manuscripts should be legible and include the contributor's name, call sign, phone number(s) and addresses (mail, email and packet, as applicable).

For a complete Author's Guide visit:

<http://www.rac.ca/tca/>

The contents of this publication are copyright, and may not be reproduced without prior consent except by a bona fide Amateur Radio organization which may reproduce them provided the author and The Canadian Amateur are acknowledged.

The Advertising Department of The Canadian Amateur, on behalf of the magazine, wholly disclaims any responsibility for the content of any advertisement contained herein and makes no representations on behalf of The Canadian Amateur as to the truth of any statement contained in any such advertising.

Radio Amateurs of Canada Inc., and the publisher and editor of The Canadian Amateur, hereby disclaim any responsibility for any statement of opinion or other statement that may be contained in any article published by The Canadian Amateur and any such statement of opinion or other statement contained in such article is solely the opinion of the author of the article and not that of Radio Amateurs of Canada Inc., or the publisher or editors of the magazine, unless it is specifically stated to be the case therein.

The Canadian Amateur is published by Radio Amateurs of Canada Inc., 720 Belfast Road, Suite 217, Ottawa, ON K1G 0Z5

Indexed in the Canadian Periodical Index: ISSN 0834-3977.

Publications Mail Agreement No. 40028682.

Registration No. 09866.

The Canadian Amateur, publié six fois par an, est destiné à fournir aux radioamateurs, à toute personne intéressée à la radio et à l'électronique et au grand public, des informations de toute nature relatives à la science des télécommunications.

Nous acceptons avec plaisir tout article, étude, suggestions, photos et lettres. Les manuscrits soumis doivent être lisibles et porter le nom de l'auteur, son indicatif, son ou ses numéros de téléphone ainsi que ses adresses postales, courriel et paquet s'il y a lieu. Si vous avez envie d'écrire pour TCA :

<http://www.rac.ca/tca/>

Le contenu de la présente publication est protégé par copyright, tous droits réservés et ne peut être reproduit sans autorisation préalable dont est toutefois dispensé tout groupement reconnu de radioamateurs sous réserve que ladite reproduction paraisse avec les mentions du nom de l'auteur et soit identifiée extraite de The Canadian Amateur. Le service publicité de The Canadian Amateur, agissant au nom de la revue, décline toute responsabilité quant au contenu des annonces publicitaires publiées et ne se porte en aucune façon garant de la véracité des propositions contenues dans lesdites annonces.

La compagnie Radio Amateurs du Canada Inc. ainsi que l'Éditeur et le Rédacteur en chef de The Canadian Amateur déclinent par les présentes toute responsabilité quant aux opinions exprimées ou autres déclarations pouvant apparaître dans tout article publié par The Canadian Amateur et déclarent en outre que toute expression d'opinion ou déclaration figurant dans un tel article représentent uniquement l'opinion de l'auteur dudit article et non l'opinion de la société Radio Amateurs du Canada Inc., ou celle de l'Éditeur ou du Rédacteur en Chef de la revue à moins qu'il soit spécifié que ce soit le cas en l'occurrence.

The Canadian Amateur est publié par la société Radio Amateurs du Canada Inc., 720 rue Belfast, Bureau 217, Ottawa, ON K1G 0Z5

Enregistré à l'Index des publications canadiennes sous le numéro ISSN 0834-3977.

Accord de publications diffusées par courrier : 40028682.

Numéro de matricule 09866.

# The RAC QSL Bureau System

<https://www.rac.ca/qs1-bureau/>

The RAC Outgoing QSL Bureau service is available to RAC members, RAC affiliated clubs (club call only) and QSL Managers who are members of RAC. Your RAC membership number must accompany each shipment of QSL cards. There are limits and restrictions for use of the Outgoing QSL Bureau. For more information, surcharges, card sorting details and some handy tips, please visit <http://wp.rac.ca/> or <http://www.magma.ca/~ve3exy/bureau.html>.

Member Societies of the International Radio Union (IARU) operate a worldwide system of QSL Bureaus. Radio Amateurs of Canada, as the Canadian member-society, operates a National Incoming QSL Bureau, and sponsors the Incoming Bureaus for the 12 Canadian call areas.

Cards received by the National Incoming Bureau from IARU Member Societies are sorted and forwarded to the Incoming Bureau in each call area. All domestic cards (VA-VE-VY) to Canadian Amateurs are to be sent directly to the RAC National Incoming Bureau and not to the Outgoing Bureau.

Note: Domestic cards sent to the Outgoing Bureau will experience a delay. Only cards for destinations outside Canada are to be sent to the Outgoing QSL Bureau.

The Incoming QSL Bureau service is a user-pay system, using one of four methods to get cards to you: (A) envelopes; (B) credits; (C) labels; or (D) combination credit with labels. \*Note: Method B is preferred.

Web: <http://wp.rac.ca/the-rac-national-incoming-qs1-bureau/>

## National Incoming QSL Bureau

Ed Spingola, VA3TPV, Manager  
PO Box 83  
Streetsville, ON L5M 1L5

## RAC Outgoing QSL Bureau

PO Box 11156, Station H  
Nepean, ON K2H 7T9  
T: 613-670-3230  
E: [ve3exy@myrac.ca](mailto:ve3exy@myrac.ca)

## VE1 – VE0 Brit Fader Memorial QSL Bureau (B)

Sponsored by the Halifax ARC  
Roger Stein, VA1RST  
12 Canary Crescent  
Halifax, NS B3M 1R1  
[burch.craft@gmail.com](mailto:burch.craft@gmail.com)  
[www.halifax-arc.org/pages/qs1-bureau.html](http://www.halifax-arc.org/pages/qs1-bureau.html)

## VE2 Bureau (A, B)\*

Jacques Dubé, VE2QK  
Résidence du Jardin  
897, rue St-Pierre, apt. 104  
Trois-Rivières, QC G9A 4W5  
[jacques.dube@cgocable.ca](mailto:jacques.dube@cgocable.ca)

## VA3/VE3 Bureau (B)

Michael Brickell, VE3TKI  
PO Box 46  
Streetsville, ON L5M 2B7  
[bureau-manager@ve3qcb.ca](mailto:bureau-manager@ve3qcb.ca)  
<https://ve3qcb.ca>

## VA4/VE4 Bureau (B)

Harm Hazeu, VE4HAZ  
7 Ashley Cove  
Winnipeg, MB R2G 2Z3  
[ve4haz@gmail.com](mailto:ve4haz@gmail.com)

## VA5/VE5 Bureau (B)

Todd Bendtsen, VE5MX  
616 Moffet Drive  
Weyburn, SK S4H 2M7  
[ve5mx@sasktel.net](mailto:ve5mx@sasktel.net)

## VA6/VE6 Bureau (B)

Jerry Spring, VE6TL  
206 Hampstead Place NW  
Calgary, AB T3A 5J2  
[springjl@yahoo.com](mailto:springjl@yahoo.com)  
[www.buro.ve6hams.ca/](http://www.buro.ve6hams.ca/)

## VA7/ VE7 Bureau (B)

Ken Clarke, VE7BC  
PO Box 1109  
100 Mile House, BC V0K 2E0  
[ve7bc27@gmail.com](mailto:ve7bc27@gmail.com)

## VE8/VY0 Bureau (A, B)\*

John Boudreau, VE8EV  
PO Box 3099  
Inuvik, NT X0E 0T0  
[ve8ev@myrac.ca](mailto:ve8ev@myrac.ca)

## VE9 Bureau (B)

Rino Deschenes, VE9VIC  
8 B rue Jeanne Mance  
Kedgwick, NB E8B1G8  
[ve9vic@hotmail.com](mailto:ve9vic@hotmail.com)  
Web: "VE9VIC" on QRZ.com

## VO Bureau (B, C)\*

Bill Kirby, VO1BB  
60 McNiven Place  
St. John's NL A1A 4X1  
[vo1bb@yahoo.ca](mailto:vo1bb@yahoo.ca)

## VY1 Bureau (A, B)

Allen Wootton, VY1KX  
Box 21217  
Whitehorse, YT Y1A 6R8  
[vy1kx@myrac.ca](mailto:vy1kx@myrac.ca)

## VY2 Bureau (A, B)

Douglas Silliker, VY2DS  
1072 Barbara Weit Road  
Summerside PE C1N 4J8

# Silent Keys – In Memoriam

With regret, we record the passing of the following Radio Amateurs.

Nous avons le regret de vous annoncer le décès des radioamateurs suivants.

- VA2GLB** – Gary Bickes, of Hemmingford, Quebec, on July 18, 2023, at age 80
- VA3GEG** – Geoffrey Geduld, of Ottawa, Ontario, on October 28, 2023, at age 93
- VA3KS** – Kieran Shepherd, of Ottawa, Ontario, on November 24, 2023, at age 64
- VE1BAW** – Barry Whynot, of Milton, Nova Scotia, on July 13, 2023, at age 79
- VE1CDC** – Angus Smiley, of Port Dufferin, Nova Scotia, on November 6, 2023, at age 84
- VE1CGI** – Hazen Middleton, of Grand Bay, New Brunswick, on October 19, 2023, at age 79
- VE1HP** – Raye Mossman, of Boularderie East, Nova Scotia, on October 27, 2023, at age 81
- VE1PO** – Gordon Ratto, of Halifax, Nova Scotia, on August 24, 2023, at age 84
- VE1RC** – Russell Canning, of Trenton, Nova Scotia, on July 10, 2023, at age 71
- VE1WLO** – William Owen, of Lower Sackville, Nova Scotia, on September 29, 2023, at age 86
- VE2KA** – Daniel Lamoureux, of Laval, Quebec, on December 2, 2023, at age 79
- VE2KLF** – Ken Fraser, of Beaconsfield, Quebec, on July 13, 2023, at age 85
- VE3CIL** – Mike Innes, of Tillsonburg, Ontario, on August 14, 2023, at age 80
- VE3CNO** – Gary Helferty, of Oshawa, Ontario, on November 5, 2023
- VE3DVI** – Fred Cross, of St. Catharines, Ontario, on July 8, 2023, at age 88
- VE3HKG** – Frances Mackenzie Roach, of Ottawa, Ontario, on November 19, 2023 at age 73
- VE3NGE** – Bruce Burgess, of Chatham, Ontario, on March 13, 2023, at age 65
- VE3PUZ** – Don Kernohan, of Richmond, Ontario, on October 4, 2023, at age 81
- VE6ATC** – Dennis Banesco, of Grand Prairie, Alberta, on October 26, 2023, at age 86
- VE6WT** – Ande Anderson, of Medicine Hat, Alberta, on October 2, 2023, at age 84
- VE7EVX** – Bob Koop, of Creston, British Columbia, on October 28, 2023, at age 82
- VE7IRT** – David Cowper, of Maple Ridge, British Columbia, on April 14, 2023, at age 63
- VE7WOL** – Gene Parkins, of Abbotsford, British Columbia, on November 14, 2023, at age 88
- VE9AC** – Andre Chiasson, of Moncton, New Brunswick, on August 22, 2023
- VE9JB** – Bryan Nuss, of Moncton, New Brunswick, on October 7, 2023, at age 76
- VE9PDZ\*** – Shelley Finn, of Saint John, New Brunswick, on August 23, 2023 at age 57
- VE9RAY** – Ray Burke, of Moncton, New Brunswick, on October 29, 2023, at age 96
- VE9YN** – Ernest Barthe, of Dalhousie, New Brunswick, on July 19, 2023, at age 78
- VO1EO** – Gerry Russell, of St. John's, Newfoundland and Labrador, on October 18, 2023, at age 74
- VO1FD** – Jack Badcock, of St. John's, Newfoundland and Labrador, on October 11, 2023, at age 91
- VO1HRP** – Ray Penney, of Green's Harbour, Newfoundland and Labrador, on August 29, 2023, at age 82
- VO1MP** – Gus Samuelson, of St. Philips, Newfoundland and Labrador, on October 30, 2023 at age 81
- VO1TO** – David Caravan, of Bay Roberts, Newfoundland and Labrador, on March 25, 2023, at age 86
- VY2WB** – Winfred Bridges, of Charlottetown, Prince Edward Island, on November 10, 2023, at age 93

**Note:** In the above list an \* indicates that a call sign has been reissued. The list of Silent Keys is prepared by volunteers. Please send obituary notices by email to [rachq@rac.ca](mailto:rachq@rac.ca) with a copy to: [ic.spectrumamateur-spectreamateur.ic@ic.gc.ca](mailto:ic.spectrumamateur-spectreamateur.ic@ic.gc.ca). For more information visit: <https://www.rac.ca/silent-keys/>



# Radio Amateurs of Canada / Radio Amateurs du Canada

## National Executive

## Regional Directors



**PRESIDENT**  
Phil A McBride, VA3QR  
134 Longfield Road  
Acton, ON L7J 2K4  
416-884-0480  
president@rac.ca



**VICE-PRESIDENT**  
Allan Boyd VE3AJB/VE3EM  
27 Red Mill Road, Box 208  
Little Current, ON P0P 1K0  
705-368-2779  
vp@rac.ca



**INTERNATIONAL AFFAIRS OFFICER**  
Serge Bertuzzo, VA3SB  
5651 Goldenbrook Drive  
Mississauga, ON L5M 3W2  
905-567-6592  
international@rac.ca



**ALBERTA/NWT/NU**  
Stephen Lee, VA6SGL  
51 Ireland Crescent  
Red Deer, AB T4R 3K8  
403-307-1643  
dir.alberta.northwest.nunavut@rac.ca



**MIDWEST**  
Ed Richardson, VE4EAR/VE4VT  
64 Avalon Road  
Winnipeg, MB R2M 2L5  
204-254-8425  
dir.midwest@rac.ca

## Deputy Directors

**ATLANTIC**  
Joe Earles, VO1BQ  
**BRITISH COLUMBIA/  
YUKON**

Allan J Munnik,  
VA7MP/VE7RMP

**MIDWEST**  
Peter Toth, VE4TTT  
(Selkirk)

## Assistant Directors

**ALBERTA / NT / NU**  
Chris Cameron, VE8WD  
Wally Gardiner, VE6BGL  
Neal Sunderland, VA6NLS  
Bill Tili, VE5FN

**ATLANTIC**  
Rino Deschênes, VE9VIC  
(North-Western NB)  
Sheldon Donaldson, VE1HQ  
(Yarmouth-Shelburne area)

Jim Fisher, VE1JF  
(Annapolis Valley /  
Fundy Shore)  
Bill Glydon, VY2LI  
(Prince Edward Island)  
Naz Simon, VO2NS  
(Labrador)

Peter Surette, VE1PJS  
(Truro and area)  
Ken Tucker, VO1KVT  
(Central Newfoundland)  
Michael Newton, VO1OK  
(Western Newfoundland)  
John Bignell, VE1JMB  
(Halifax and area)

## BRITISH COLUMBIA / YUKON

Lou Beaubien, VE7CGE  
(Burnaby, BC)  
Richard Thompson, VE7XT  
(Victoria, BC)  
Ross Wilmot, VA7NRW  
(Surrey, BC)

**MIDWEST**  
Joe Musgrave, VE5JM  
(Lloydminster)  
Doug Pfaff, VE5DCP  
(Regina)  
Dave Scarfe, VE5UO  
(Saskatoon)

**ONTARIO SOUTH**  
Keith Baker, VA3KSF  
(Samia)  
Jerry Beneteau, VE3EXT  
(Essex & Kent)  
John Lorenc, VA3WM  
(Niagara)  
Stan Leschinsky, VE3TW  
(Greater Toronto Area)



**QUEBEC**  
Patrice Bourdages, VE2PTB/VA2PK  
1266 rue Andante  
Québec, QC G3K 2P7  
581-909-2778  
dir.quebec@rac.ca



For RAC Membership Inquiries and Change of Address please contact RAC HQ at: rachq@rac.ca



**REGULATORY AFFAIRS OFFICER**  
Dave Goodwin, VE3KG  
141 Acton Drive  
Smiths Falls ON K7A 5B8  
613-430-4911  
regulatory@rac.ca



**CHIEF INFORMATION AND TECHNOLOGY OFFICER**  
Jeff Dale, VA3JSP  
Box 91  
Hammond, ON K0A2A0  
cito@rac.ca



**COMMUNITY SERVICES OFFICER**  
Jason Tremblay, VE3JXT  
3 Smyth Crescent  
Beeton, ON L0G 1A0  
705-890-9967  
community@rac.ca



**ATLANTIC**  
Al Penney, VO1NO  
386 Victoria Road  
Aylesford, NS B0P 1C0  
(902) 847-0554  
dir.atlantic@rac.ca



**ONTARIO NORTH/EAST**  
Craig Delmage, VE3OP  
30 Forest Gate Way  
Nepean, ON K2G6P3  
343-988-6336  
dir.ontario.north.east@rac.ca



**CORPORATE SECRETARY**  
Alvin (Al) M. Masse, VE3CWP  
440 Maple Avenue  
LaSalle, ON N9J 1P4  
519-734-0026  
secretary@rac.ca



**TREASURER**  
Margaret Tidman, VA3VXN  
583 Drummond Concession 5B  
Perth, ON K7H 3C8  
613-263-5486  
treasurer@rac.ca



**HONORARY LEGAL COUNSEL**  
Marcel D. Mongeon, VA3DDD  
Suite 374  
3-35 Stone Church Road  
Ancaster, ON L9K 1S4  
905-390-1818  
legal@rac.ca



**BRITISH COLUMBIA/YUKON**  
Keith Witney, VE7KW  
2 - 1443 Edwards Street  
PO Box 78042 RPO Northside  
Port Coquitlam, BC, V3B 7H5  
604-475-5254  
dir.bc.yukon@rac.ca



**ONTARIO SOUTH**  
Barry Brousseau, VE3SLD  
67 Deeparth Drive  
Guelph, ON N1K 1V1  
519-829-9697  
dir.ontario.south@rac.ca

## Radio Amateurs of Canada | Contact information for Section Managers

**Alberta (AB)**  
Ron Pettigrew, VE6RWP  
29 Michigan Street  
Devon, Alberta, T9G 1H7  
ve6rwp@gmail.com  
780-668-3218

**Nova Scotia (NS)**  
Dave Hull, VE1HUL  
45 Archibald Street  
Truro, NS  
B2N 4R5  
d.hull@ns.sympatico.ca

**Ontario East (ONE)**  
Michael Hickey, VE3IPC  
2768 Chartrand Road  
Lefaire, ON K0B 1J0  
ve3ipcc@gmail.com

**Prince Edward Island (PE)**  
Bill McMaster, VY2WM  
11 Birch Hill Drive  
Charlottetown, PE  
C1A 6W4  
bill@vy2wm.ca

**British Columbia (BC)**  
Acting: Bill Gipps, VE7XS  
9362 - 206A Street  
Langley, BC  
V1M 2W6  
bill.gipps@gmail.com

**New Brunswick (NB)**  
Jean-Paul (JP) LeBlanc, VE9BK  
13 Stelor Drive  
Lutes Mountain, NB  
E1G 5E5  
medals2@gmail.com+

**Ontario Golden Horseshoe (GH)**  
Ian Clarke, VA3KCP  
2 Forest Laneway, Suite 1801  
North York, ON M2N 5X7  
k9lyfgrd@gmail.com

**Quebec (QC)**  
Sylvain Lamarre, VE2LAM  
506 rue Père Joseph Jean  
Rimouski, QC  
G5N 1L18  
ve2lam@raqi.ca

**Manitoba (MB)**  
Jan Schippers, VE4JS  
202 Sadler Avenue  
Winnipeg, MB  
R2M 1P3  
ve4js@myrac.ca

**Newfoundland-Labrador (NL)**  
Boyd Snow, VO1DI  
78 Main Road  
Bristol's Hope, NL  
A1Y 0A7  
vo1cbs@eastlink.ca

**Ontario North (ONN)**  
Allan Boyd, VE3AJB  
27 Red Mill Road, Box 208  
Little Current, ON P0P 1K0  
ve3ajb@vianet.ca

**Saskatchewan (SK)**  
Vacant

**Ontario South (ONS)**  
Brett Gilbank, VE3ZBG  
225 Periwinkle Road  
London, ON, N6M1B7  
ve3zbg@gmail.com

**Territories (TER)  
(Northwest Territories/  
Nunavut/Yukon)**  
Vacant



# President's Message / Message du Président

Phil A McBride, VA3QR | [president@rac.ca](mailto:president@rac.ca)

## Happy New Year and Welcome to 2024!

Last year was a very busy year for our national organization as we celebrated our 30th Anniversary throughout the year.

The last half of the year was even busier than the first half. In July, Radio Amateurs of Canada hosted the Youth On The Air (YOTA) Summer Camp 2023 at Carleton University in Ottawa and from all accounts it was a smashing success. I am very pleased to announce that we will once again host YOTA Camp in 2024! The event will take place between July 7-12 at Mount Saint Vincent University in Halifax, Nova Scotia and applications are now being accepted (see page 13).



In August, we held our Planning Meeting and Annual General Meeting in tandem with the Halifax Amateur Radio Club's 90th Anniversary Celebration and Conference. All of the events were wildly successful. I would like to thank the Halifax Amateur Radio Club and the Salvation Army for hosting us. You can find an article about the club's history and celebration on page 59.

The World Radiocommunication Conference (WRC-23) was held in Dubai, United Arab Emirates from November 20 to December 15. RAC Special Advisor Paul Coverdale, VE3ICV, did a fantastic job, both in Dubai and at the Preparatory Meetings which were held in Geneva, Switzerland during the preceding four-year period. While in Dubai, Paul prepared a short summary for this issue of TCA (see page 26).

## Bonne année, et bienvenue en 2024!

L'année écoulée a été une période fort occupée pour notre organisation nationale, qui a célébré son 30e anniversaire en menant à bien une foule d'activités s'étalant du début à la fin de l'exercice.

Le second semestre a été encore plus chargé que le premier. En juillet, Radio Amateurs du Canada a accueilli le Camp d'été intitulé Jeunes sur les ondes 2023 (Youth On The Air - YOTA) à l'Université Carleton (Ottawa), et à en juger d'après tous les témoignages recueillis à son sujet, cet événement a remporté un succès fracassant. Je suis très heureux de vous annoncer que nous accueillerons de nouveau le Camp YOTA en 2024! Il aura lieu du 7 au 12 juillet à l'Université Mount Saint Vincent, à Halifax (Nouvelle-Écosse), et nous acceptons d'ores et déjà les demandes de participation (voir page 13).

En août, nous avons tenu notre Réunion de planification et notre Assemblée générale annuelle parallèlement à la célébration du 90e anniversaire et à la Conférence du Halifax Amateur Radio Club. Tous ces événements ont obtenu un vif succès. J'aimerais remercier le Halifax Amateur Radio Club et l'Armée du Salut de leur cordial accueil. Un article sur l'histoire de ce club et sur les célébrations en question figure à la page 59.

La Conférence mondiale des radiocommunications (CMR-23) s'est tenue à Dubaï (Émirats arabes unis) du 20 novembre au 15 décembre. Le conseiller spécial de RAC, Paul Coverdale (VE3ICV), a accompli un travail formidable, tant à Dubaï que dans le cadre des Réunions préparatoires qui ont eu lieu à Genève (Suisse) au cours de la période de quatre ans qui a précédé. Pendant son séjour à Dubaï, Paul a rédigé le bref compte rendu publié dans le présent numéro de TCA (voir page 26).

L'équipe de RAC compte maintenant plusieurs nouveaux visages! J'aimerais souhaiter la bienvenue aux personnes suivantes :

- Patrice Bourdages, VE2PTB, qui assumera les fonctions de directeur régional pour le Québec en remplacement de Guy Richard, VE2XTD, qui a occupé ce poste au cours des six dernières années, soit la durée maximum autorisée. Nous remercions Guy des services qu'il nous a fournis avec tant de dévouement pendant quatre ans. Nous sommes impatients de collaborer avec Patrice pour promouvoir les intérêts des radio amateurs au Québec et partout ailleurs au Canada.
- Ian Clarke, VA3KC, en tant que nouveau directeur de section pour la région du Golden Horseshoe de l'Ontario. Ancien coordonnateur de district chargé des interventions d'urgence pour Toronto, Ian entrera en fonctions le 1<sup>er</sup> janvier. Nous lui souhaitons la bienvenue au sein du conseil de section et serons heureux de collaborer avec lui sur le terrain.

There are several new faces at RAC! I would like to welcome:

- Patrice Bourdages, VE2PTB, as the new Quebec Regional Director. Patrice is replacing Guy Richard, VE2XTD, who has served as Quebec Director for the last six years – the maximum amount of time permitted. Thank you Guy for your years of dedicated service. We look forward to working with Patrice to further the interests of Radio Amateurs in Quebec and across Canada.
- Ian Clarke, VA3KC, as the new Section Manager for the Ontario Golden Horseshoe Section. Ian Clarke, VA3KCP, formerly District Emergency Coordinator for Toronto, assumes the role effective January 1. We welcome him to the Sectional Council and look forward to working with him in the field.
- Aurele Alain, VE3RDI, joins us as RAC's new consolidated QSL Manager. In addition to managing RAC's QSL cards and Logbook of The World (LoTW) uploads, he will also coordinate RAC's call sign presences on the web and manage the logs for all 23 of RAC's call signs. Aurele assumes these responsibilities from Denis Rule, VE3BF and Richard Ferch, VE3KI. We thank Denis and Richard for their work and look forward to working with Aurele.

All of the incumbent Executive members, myself included, indicated they were willing to serve further two-year terms. Accordingly, all were nominated and acclaimed by the Board of Directors at our November 2023 meeting.

Planning is underway for Part 2 of Operation Dark Skies (see page 40) and World Amateur Radio Day in April, the Dayton Hamvention and the Canada-wide Science Fair in May, Field Day in June, the RAC Canada Day Contest in July, and of course the RAC Challenge and Operating Awards throughout the year (see page 62). I'm looking forward to another year of advancing the cause of Canadian Radio Amateurs here at home and abroad.

### **Former RAC President Daniel Lamoureux, VE2KA SK**

Radio Amateurs of Canada received the sad news that former RAC President Daniel Lamoureux, VE2KA, became a Silent Key on December 2, 2023, at the age of 79.

In addition to serving as RAC President, Daniel was also a member of the Administrative and Finance Committee for several years. He also served as Area A Director of Region 2 of the International Amateur Radio Union (IARU).

Daniel served as President of the Fédération des clubs radioamateurs du Québec (RAQI) for several years from the mid-1990s to the early 2000s. Please stay tuned to the RAC website for more information.

*Phil A. McBride, VA3QR/VA3KPJ – RAC President and Chair*

- Aurèle Alain, VE3RDI, qui se joint à nous en tant que nouveau directeur des services QSL regroupés de RAC. Outre la gestion de l'acheminement des cartes QSL confié à RAC et du téléchargement des données à stocker dans le système Logbook of The World (LoTW), il coordonnera l'attribution des indicatifs concrétisant la présence de RAC sur le Web et gèrera les journaux de bord tenus à jour pour la totalité des indicatifs (au nombre de 23) de RAC. Aurèle prend ainsi la relève de Denis Rule (VE3BF) et de Richard Ferch, VE3KI, que nous remercions de l'excellent travail qu'ils ont accompli. Nous nous ferons un plaisir de le soutenir dans l'exercice de ses nouvelles fonctions.

Tous les membres de l'Exécutif actuellement en poste, y compris votre serviteur, ont indiqué qu'ils étaient prêts à continuer d'y siéger pendant un nouveau mandat de deux ans. En conséquence, tous ont été proposés à titre de candidats et élus par acclamation par le Conseil d'administration à l'occasion de notre assemblée de novembre 2023.

Les préparatifs sont en cours pour la partie 2 de l'Opération Ciel sombre (voir page 40) et pour la Journée mondiale de la radio amateur en avril, la Hamvention de Dayton et l'Expo-Sciences pancanadienne en mai, la Journée sur le terrain en juin, le Concours RAC de la Fête du Canada en juillet, et évidemment le Défi et les Prix pour opérations RAC proposés pendant toute l'année (voir page 62).

J'ai la ferme conviction que l'année à venir nous offrira de nombreuses occasions de continuer à promouvoir la cause des radio amateurs canadiens, dans notre pays et à l'étranger.

### **L'ancien président de RAC Daniel Lamoureux, VE2KA SK**

Radio Amateurs du Canada a reçu la triste nouvelle que l'ancien président de RAC, Daniel Lamoureux, VE2KA, est devenu un Silent Key le 2 décembre 2023, à l'âge de 79 ans.

RAC tient à offrir ses sincères condoléances à sa famille et à ses amis. Un article hommage sera publié dans un prochain numéro du magazine The Canadian Amateur.

En plus d'être président de RAC, Daniel a également été membre du comité administratif et financier pendant plusieurs années. Il a également été impliqué dans l'administration de RAC en tant que président et conférencier international de l'IARU pour la région 2.

Il avait été président de la Fédération des clubs radioamateurs du Québec (RAQI) durant plusieurs années du milieu des années 90 jusqu'au début des années 2000. Restez à l'écoute de ce site Web pour plus d'informations.

*Phil A. McBride, VA3QR/VA3KPJ – Président de RAC*

*– Traduction par Jacques Roland, VA3DLZ. Merci Jacques!*



## Nouveau directeur du Québec : Patrice Bourdages, VE2PTB/VA2PK

Radio Amateurs du Canada souhaite la bienvenue à Patrice Bourdages, VE2PTB/VA2PK, en tant que nouveau directeur du Québec.

Patrice est né à Grand-Mère, Québec et a grandi à Sorel-Tracy près de Montréal. Il a fait ses études en comptabilité financière au CEGEP de Sorel-Tracy et a complété plus tard un certificat en informatique de gestion appliqué avec l'Université du Québec à Trois-Rivières.

Il a travaillé en intelligence d'affaires auprès de multiples compagnies d'assurances générales et quelques ministères du Gouvernement du Québec de 1991 à aujourd'hui. Il est un spécialiste du logiciel SAS et a donné multiples conférences partout au Canada.

Patrice est membre des Forces canadiennes depuis plus de 36 ans maintenant. Il s'est impliqué auprès de la jeunesse canadienne au sein du Programme des Cadets du Canada. Il a occupé multiples rôles et en est actuellement à son cinquième commandement d'une unité de cadets.

En 1977-78, il tente de suivre son cours de radio-amateur pour la première fois mais sans succès. Il se reprend en 2011 et passe avec succès son examen et obtient sa licence de base avec distinction. Patrice est très actif en HF avec de multiples QSO en mode numérique. Il est visible principalement en FT-8 et FT-4 sur les bandes de 40, 20, 15 et 10 mètres.

Étant membre du Club Radio Amateur de Québec (CRAQ) depuis 2011, il anime le réseau local 2m le mardi soir et ce depuis plusieurs années. Il a été membre du Conseil d'administration du Club pendant un an. Il a participé à presque tous les Field Day du club. Il a réinstauré la chasse à l'émetteur il y a quelques années et prévoit continuer dans cette veine. Il a été vérificateur du club et participe le plus souvent possible aux activités sociales et techniques.

Patrice aimerait voir grandir la radio-amateur au Canada et voir de plus en plus de jeunes au sein de l'organisation.



## New Quebec Director: Patrice Bourdages, VE2PTB/VA2PK

Radio Amateurs of Canada would like to welcome Patrice Bourdages, VE2PTB/VA2PK, as the new Quebec Director.

Patrice was born in Grand-Mere, Quebec and grew up in Sorel-Tracy near Montreal. He studied financial accounting at the CEGEP in Sorel-Tracy and later completed a certificate in applied management information technology with the University of Quebec at Trois-Rivières.

He has worked in business intelligence with multiple general insurance companies and several ministries of the Government of Quebec from 1991 to today. He is a specialist in SAS software and has given numerous conferences across Canada.

Patrice has been a member of the Canadian Forces for over 36 years. He was involved with Canadian youth within the Canadian Cadet Program. He has held multiple roles and is currently in his fifth command of a cadet unit.

In 1977-78, he tried to take his Amateur Radio course for the first time but without success. He recovered in 2011 and successfully passed his exam and obtained his Basic certification with distinction.

Patrice is very active on HF with multiple QSOs in digital mode. He is visible mainly in FT-8 and FT-4 on the 40, 20, 15 and 10 metre bands.

He has been a member of the Club Radio Amateur de Québec (CRAQ) since 2011 and has been hosting the local 2 metre network on Tuesday evenings for several years. He was a member of the Club's Board of Directors for a year. He has participated in almost all of the club's Field Days. He also reinstated their foxhunt a few years ago and plans to continue in this vein. He has been the club's auditor and participates as often as possible in social and technical activities.

Patrice would "like to see Amateur Radio grow in Canada and see more and more young people within the organization".



## Aurele Alain, VE3RDI: New Consolidated QSL Manager

I am originally from Bathurst, New Brunswick and moved to Ottawa in 1986 to work in Information Technology.

I was fascinated by radio all my life, almost as much as model airplanes. I earned my Amateur licence in 1989. I had to put Amateur Radio on hold while having a young family but I did fly model airplanes on 6m for many years.

As I get closer to retirement I thought it was a good time to get back into it with a view towards public service. Radio Amateurs of Canada is a volunteer-based organization and I felt that now was the right time for me to make a contribution. I look forward to defining the role of Consolidated QSL Manager and working with the RAC Executive.



# Six Metres and Down...

## Happy New Year! 42 and Counting...

I can't believe that this column is for the first issue of *The Canadian Amateur* of 2024! I started writing "Six Metres and Down" with the Canadian Radio League (CRRL) way back in 1988 and figured I'd do it for a "couple of years". Fast-forward 42 years – including 25 years with the TCA Editor Alan Griffin – and I am still struggling to meet deadlines to share the wonders of Amateur Radio with you. I hope you all enjoy reading it and that its inspired you to get on and explore our bands above 30 MHz!

I also hope that you appreciate the hard work the RAC volunteers do on behalf of us all, in terms of advocating for our continued use of spectrum for the good of our fair land. I would ask that any of you who read this column submit reports from your neck of the woods, as well as technical tips and ideas. That's what this is all about – sharing and inspiring.

### Solar Activity Cycle 25

After a brief downturn in early November, a large sunspot group came around and during the last week of November the flux headed back up to 190 and we did get some F2 openings on 50 MHz, as noted below. However, with activity comes flares and HF blackouts. Keep in mind that this also opens the VHF bands for Aurora, Auroral E and enhanced north-south propagation, as well as antipodal hops, with northern Canadians working into places like Antarctica!

If things stay on track, the spring should see some DX openings to the South Pacific again and by the fall we may see some solid F2 to Europe, the South Pacific and Asia. Watch the space weather reports, the American Radio Relay League's propagation bulletins and other sources for the latest conditions.

### Fall 50 MHz Report

Thursday, October 19 was a good day for me as we were finally in the hot spot for some of the Trans-Equatorial Propagation (TEP) Sporadic Es DX with QSOs to 3B8FA and 3B8CW in grid LG89 Rodriguez Island in the Indian Ocean, between 1528 and 1535 UTC, followed three hours later with 7Q7MEH in grid



### Cross-Border VHF Meeting 2023

On Saturday, October 14, the Ontario VHF Association (VE3VHF) and the Rochester VHF Group (W2UTH) held their second annual joint meeting in Stevensville, Ontario near Fort Erie. As shown in the above photos, we had a great turnout of 40 people from both sides – and there was no snow this year. The group was treated to some great presentations and demonstrations of VHF, UHF and Microwave gear including a neat Pluto multiband system put together by Andy, K0SM/2. Next year's event will be held on the American side so everyone is looking forward to that.

KH67 in Malawi, Africa worked. All were new DXCC as well bringing my DXCC total to 156 confirmed.

We also had some days of very good TEP E-skip into South America – particularly on October 20 with many Brazilian stations worked between 0017 and 0049 UTC including PP7ZP in GG53, PY2XB in GG66, PP5AMP in GG52, PY5EN in GG54, and PY4AQA in GG88 for new grids.

On October 21, ZL3OZ copied VE3OIL, VE1PZ, VE3VN, VE3BW, VA3DX and VE3EJ! VE1PZ was over a 15,885 kilometre path!

Rob, VE3ARF, in FN25 worked 35 South American stations on October 20 covering most of Brazil, Argentina and Uruguay with the band open well past 11 pm!

Dave, VE3KG, in FN24 wrote in with a fine report:

"Since building my new station in my new location in FN24, I have been fairly active on 6 metres. Starting in late March 2023,

I worked LU5FF on CW. Shortly after that, I overcame my distaste for the FT8 and joined Ron, VE3VN, Paul, VA3LX and Cezar, VE3LYC, to follow the DX on that mode and share news in a small email group.

Today, October 19, I worked 3B8FA and 3B9FR for countries #72 and #73 respectively. That was in less than seven months!"

The next day was even more spectacular with an opening to the South Island of New Zealand. ZL3NW and ZL3RC were copied in there solid from grid RE66 at 0041 UTC. ZL3RC was copied and worked as far east as VE1PZ on a tight path just below the great lakes. Among the others in the line of fire were VA3DX, VE3BW, VE3EDY, VE3IKV, VE2DFO and VE1PZ.

The precursor to that opening was my copying the guys in Mexico in here, and we knew that there was a chance that a Mexican link could couple into the TEP zone and it did!

Later that day at 1840, we worked VP8LP in GD18 Falkland Islands followed by a large number of CX stations mostly in GF15.

From FN04, Bob, VE3WY, worked VP8LP for a new one over a 10,025 kilometre path (6,229 miles), as well as 6Y5NH in FK18, LU1WFU in FE62 and LW2EM in FF81 and lots of CX stations!

A few hours later at 0054 UTC on October 22 we worked Bob, ZL1RS, on the North Island in RF64 as well as XE2ML in DL74. Once again there was that western link leading to the ZL contacts. Bob was widely worked again by many. ZL3RC also worked VE3IKE, VE3EDY, VE3EJ, VA3DX, VE1PZ (15,729 km) and VE3VN.

For me these ZL contacts represent finally competing after 40 years of working New Zealand (North and South Islands) and it was DXCC #157 for VE3DS. Next stop will be VK and VU, VS and beyond, eh!

October 29 brought a brief opening to Africa with the TZ6HY/B on 50.006 copied weakly. Unfortunately, Jeff, TZ4AM, was in the United States at the time so hopefully he will be QRV in December. Jeff runs 1500 watts and a 10-element Yagi from his station in Mali.

November was still providing some north-south paths and PZ5RA and TI3ATW were worked on November 5 at 1430 UTC by VE3DS and others and CE6UFF and LU8YD, LU3VA, PY2WC were worked at 2317.

That path over Africa kept appearing as well over the next week with signals at times very strong. In fact, on November 6, we worked 7Q6M at 1413 UTC on FT8 and SSB in Malawi. Then at 1610 UTC, we again worked Robert, 3B9FR, in grid MH10 in Mauritius who was S9+ with his 70 watts and 6-element quad!



**Dave McLennon, VO1LM, in his shack and above with the 6 metre tower and beam in his backyard.**

We corresponded by email and he sent me a paper QSL for the contact!

During the opening Glenn, VA3DX, worked 7Q6M on CW for a new DXCC!

Interestingly, right after working 3B9FR we had an opening to Spain and Portugal which were on the same beam heading.

At 1607 UTC, VE3DS worked EA5GPL in IM98, EA5/LA2PC, CT1JMA, EA7BHO, EA7MT, CT1EEX, EA4GOY, EA5BY and finally EA5RM in IM98 at 1631.

Frank, VO1HP, sent the following report:

“Just a brief update on 6m FT8 activity in October here in VO-land.

October 19 at VO1HP, the band started to come alive with many US and Canada QSOs in the log. Continued with many North American into October 20.

October 22 the band opened at 19:22 – 21:31Z into South America. In the log LU1WFU; VP8NO (#116 DXCC); LU8WAG; LU2BA; PY3DCC; CX7BBR.

October 26 at 19:23 CX3VB.

October 30 at 15:25 3B8FA (incomplete); at 17:59 to 18:10 HC2DR; VP8NO; HC1MD/2.

October 30 at 17:12 ZD7CTO worked by VO1CH.

October 31 at 13:22 3B8FA (#117 DXCC); at 13:26 3B9FR (#118 DXCC).“

Dave, VO1LM, dropped, in a note too:

“I’ve been on 6 metres since the spring of 2019. Primarily FT8. Started with an MFJ dipole up 6.5 metres and made only one contact.



Then by June 2019, I purchased a Maple Leaf Communications 6 metre 3-element beam (6 db gain) from Frank, VO1HP. Then I got a Yaesu G-800DXA rotator/controller from Radioworld. The beam is set up 8.5 metres from ground which is 95 metres elevation above sea level, and 5 kilometres west of the North Atlantic. (On a dark night you can see the lights of Europe...hi) Dave sent along the above station picture!

My rig is a Yaesu FTDX-3000 with onboard sound card run at 50 watts. The computer is an Acer desktop running Ham Radio Deluxe and WSJT-X on FT8 which auto uploads."

Note that Dave worked his first Argentinian station during the October 20 opening as well. Congratulations!

Chris, VO1CH, in GN37 uses a 3-element SteppIR modified into a wide spaced 4-element. On November 7 between 1303 UTC and 163930 UTC, he worked ZS6NJ in South Africa, V51JP in Namibia, A25R in Botswana, ZS6TX/6, F6IDT, V51WW, ZS6WN, 3B9FR, TJ9MD and FR400!

You can sense the excitement at all this DX for the boys on the Rock, surrounded by salt water and open Ocean. DX heaven!

Meanwhile far to the south, on October 21, Enrique, CP6UA, in Bolivia (FH82) worked into Zone 23 with BG9NJY at 0359 UTC. It's a different world down in the tropics. There have been multiple Japan to Argentina/Brazil SSPA (solid state power amplifier) type openings and some long path openings as well!

Enrique is in the last country I need in South America and again it's been a 40 year trial to snag him, so far without success. He is rarely seen up here due to his proximity to the TEP zone so its difficult for him to access the bounce. We have seen him on FT8 but with rapid QSB and multipath distortion. Apparently, a lot of the guys in South America don't hear us even though we hear them. Is it cross-polarization during the signal transit? Not sure.

Things then went quiet on both 6m and 8m as the solar flux sagged down into the 130s and sunspots disappeared. As of this writing, a new group of spots has rotated into view, the flux is up at 190 and there have been some minor flares so we did get a couple of days of F2 at the end of November.

On November 25, the band opened to Trinidad and Tobago briefly at 1402 UTC with 9Y4D.

On November 26, the band opened to Spain and Portugal with CT1APN in IM59 at 1515 UTC, and then EA7SG in IM76 and CT2FEY and CT7BIZ in IN50 and IN60 were worked, before fading out at 1524.

November 27, was a busy day for everyone from VO1, VE1, VE2 and VE3 with many United Kingdom stations in on F2, including EI7BMB in IO63, MOBUL in IO82, MM0AMW in IO75, G16ATZ in IO74 and MI0BOT worked between 1408 and 1443.

November 30 was also another busy F2 day but I was busy with meetings. I did manage to work ON4IQ in JO20, G0BNR and M5BFL.

December 1 found the band shifted far south due to solar flares with YV6IA worked in FJ78 at 1504, PR7XB in Brazil as well as CO2QU in Cuba EL83. I'm sure there will be many more F2 days which we will report next issue. Let us know what you worked!

## 144 MHz

Ike, VE3IKE, down in Leamington, Ontario has been skedding Rick, W5EME, in EM32 in Shreveport, Louisiana daily and they have been able to work almost every day using JT65. We are talking under dead band conditions, with maybe some random meteors thrown in. Rick runs high power and has stacked Yagis, but Ike is running a single Yagi and lower power so its pretty amazing. If you are looking for something to experiment with try some long-distance terrestrial contacts or Earth-Moon-Earth communication (EME or Moonbounce) using JT65.

In FN02, Mike, VE3CKO, has his tower up and antennas connected so he's QRV up to 1296 now!

On November 23, Peter, VE7PS, out in Grand Forks, British Columbia, DN09, worked 4W8X East Timor, in PI23 on 144 MHz EME. Peter mentions that signals were great, but he had to wait until after midnight his time while the moon cleared the "palm trees". Peter was their third contact in the log and first Canadian! Peter's station is 4x 12-element M2 Yagis, cavity preamp and 1 kilowatt from a homebrew W6PO 8877 amp.



## The VHF/UHF Century Club

### 222 MHz

The Tuesday night activity continues between 7 pm and 9 pm with activity focused by K1WHS in Maine and activity ranges from N.C. and out to Missouri in the west for us here in Ontario.

It's good to see additional activity in British Columbia with the West Coast VHF gang being active.

One of the awards that ARRL has is the VHF/UHF Century Club aka VUCC. The award is given for confirmation of QSOs with 100 grids on 50 and 144 MHz; 50 grids on 222 and 432; 25 grids on 902 and 1296; 10 grids on 2304; and 5 grids on 3400 and above.

Even though I was the first ARRL and RAC card checker for VUCC, I didn't really pursue it much except by default on 6m while chasing DXCC.

So last winter I sat down and started figuring if I had anything on the other bands... and I did! The results are shown in the above photo. Yes I still need 5.7 and 10 GHz, but hey it's fun!

As an aside there is also an award called the Fred Fish Memorial Award which is for working all continental US grids and some of our Canadian Amateurs are closing in on it!

Radio Amateurs of Canada has the Canadaward for working all Canadian Provinces/Territories. That to my mind is one of those under-appreciated awards given our vast geography! Now why not take up that challenge on VHF! What about 10 GHz!

### 902 MHz First Worked All States (WAS) Achieved

On October 22, Al, W5LUA, became the first Amateur to work all US states on 902 MHz (33 cm). Barry, VE4MA, writes:

“KA6U has been out on a huge 902 EME rove and gave Al his last state this morning, which was believe it or not, Wisconsin. I have been trying to get on 902 EME, but have been having many problems and have not been successful there.

There is a core group that has been pushing for 902 WAS (many of the guys involved in the 222 push a few years back) that are getting close themselves. The cornfield EME guys down by Cedar Rapids are part of that group.

I know the intent is for this group to move up to 2304 next to get the first WAS done there”

### Microwave Update

Speaking of events, the 2024 Microwave Update will be held in British Columbia from October 3 to October 5. The event is sponsored by the Western Canada Weak Signal Association (<https://wcwsa.ca>) and the Pacific Northwest VHF Society (<http://www.pnwvhfs.org>). Their website indicates that the “planned location is 10 miles south of Vancouver International Airport in the new upscale Casino” and they already have a huge roster of speakers. The event will feature a fleamarket and a dinner with guest speaker and more.

A bunch of us in Ontario are trying to find a private jet and pilot to fly out there – preferably a Globemaster so we can haul goodies back!

Anyone available please let us know. Failing that I know Peter, VA3ELE, is planning a drive with grid-hopping all the way out and back! More on this event over the next months. Book early! Don't be disappointed! For info check this link: <https://microwaveupdate.org/>

### Six Metre DXCC

I was doing a presentation to the Skywide Amateur Radio Club (<https://www.skywide.ca>) and did a tabulation of 6m DXCC held by Canadians.

The tally is now: VE1YX, VE1RAA, VE1ZZ, VE3RM, VE3KKL, VE3DSS, VE3FIT, VE3FF, VA3DX, VE3BW, VE3EK, VE3DS, VA2WA, VE2XK, VE3EDY, VE1JF, VA3LX, VE3CFK, VE3ARF, VE2TZT, VE1JBC, VY2ZM, VO1CH, VE3EJ, VE1PZ, VE3LYC, VE1DX and VE3XN!

Hopefully we will see some of the VE4, VE5, VE6 and VE7 gang make the grade this cycle too!

### ARRL January VHF Sweepstakes

The January contest is one of the three major ARRL VHF contests that tests our collective skills of communicating over large distances using the resources of our VHF bands and, in essence, testing our emergency communications capabilities using no repeater ad hoc networks!

Want to see what you can work with your FM setup? You can do it in the contest on simplex. I think that aspect of EmComm capabilities has kind of been lost in the general “contest” mania over the years, but its an essential part of why we exist – experimenting, social communicating, and emergency comms.

The contest takes place on January 20–22, starting at 1900 UTC. Rules can be found at: <http://arrl.org/january-vhf>

Well that's it this time. Please send your reports, anecdotes and photos. Let's make 2024 a great VHF year!

– 73 Dana, VE3DS

TCA 



The advertisement features a large, stylized 'Max' logo in the center, with 'Super' in a yellow starburst to the left and 'Series' in a purple oval to the right. Above the logo is the 'premier' logo with a globe icon. To the right of the logo is a blue box with the text 'Great performance meets low price'. Below the logo is the text 'Tri Band Antennas' in a bold, black font. At the bottom left, the phone number '(514) 900-8442' is displayed in yellow, and below that is the website 'premier01.com/SuperMax.html'. At the bottom right, the address 'Champlain, NY 12919 Cornwall, ON Canada' is listed. The background is a light blue with a subtle pattern.

## Donate to Defence of Amateur Radio Fund (DARF) Trust

The sole purpose of the Defence of Amateur Radio Fund (DARF) Trust is to support the travel expenses of a certified Amateur(s) as a member of the Canadian official delegation at the International Telecommunication Union's World Radiocommunication Conferences (WRC) and Preparatory Meetings which are usually held in Geneva, Switzerland.

World Radiocommunication Conferences – organized and held by the International Telecommunication Union (ITU) every four years – update the Radio Regulations, the international treaty that, among other things, sets out the frequencies on which radio services such as the Amateur Radio Service may operate. WRC-23 was held in Dubai, United Arab Emirates from November 20 to December 15 (see pages 26-28).

The RAC delegate's role is to assist our regulator – Innovation, Science and Economic Development Canada (ISED) – with all WRC agenda issues that may influence allocations to the Amateur Radio Service. This may include helping defend existing Amateur bands from being reallocated or being subject to harmful sharing by other interested parties. There may also be an agenda item offering the opportunity to advocate for a new allocation or to defend the use of existing Amateur Radio spectrum by other Services seeking to gain access to the spectrum.

Radio Amateurs have a seat at the table – in fact, there is a specific Working Party which includes the Amateur and Amateur Satellite Service in its title – but they need to be able to participate directly. While allowing RAC membership of the Canadian delegation, ISED does not provide any funds towards their participation.

As most of these meetings are usually held in Geneva, one of the most expensive cities in the world, DARF's funding is essential. The DARF Trust's role is to provide funding for our delegate's travel and living expenses in order to attend these various conferences.

Without DARF, there would be no Canadian Amateur presence at these international meetings or in the many pre-meetings that take place developing and working out what ultimately becomes Canada's position.

WRC-23 Summary and Results – pages 26-28

DARF Annual Report 2022:  
<https://www.rac.ca/darf/>

Donate to DARF:  
<https://www.rac.ca/donation/>

TCA 

# RAC Scholarships 2023: The Importance of Showing Up!

**Albert Eros, VE4ZB**  
**RAC Grants**  
**and Awards**  
**Coordinator**



Radio Amateurs of Canada is pleased to announce the granting of scholarships of \$1,000 to each of the following

Canadian Amateurs who are studying full time at the post-secondary level.

Radio Amateurs of Canada provides scholarships and grants thanks to the RAC Foundation. RAC operates the RAC Foundation in cooperation with the Community Foundation of Ottawa (CFO) which administers and invests donated funds and disburses the earnings from those invested funds to scholarship and grant applicants upon approval and direction from RAC.

It is thanks to the continued generosity of Amateurs and Amateur Radio clubs from all parts of Canada that we can support talented Canadian Amateurs who will contribute to the Amateur Radio Service for years to come. Contributions to the RAC Foundation are tax deductible and are most welcome!

Congratulations to all of the 2023 RAC Scholarship recipients!

## **New Scholarship Announcements:**

**Alexander Fogal, VA3LML**  
**Guelph, Ontario**  
**Wilfrid Laurier University**

"I have a Bachelor's of Science degree at Wilfrid Laurier University and am currently working on my Master's degree.

I am an avid hobby electronics enthusiast, which intersects with radio often enough in the form of kits and other small station pieces and controllers.

My main extra-curricular interests include contesting, camping and hiking, during which I enjoy the occasional Parks On The Air (POTA) activation, and generally field-testing my portable radio setup and skills. This presents a new and exciting challenge to me, since most of my radio experience comes in the form of contesting (especially digital contesting).

My goal is to obtain a position at Environment and Climate Change Canada (ECCC), where I have done internships in the past. Ideally, this would be in the Climate Change science branch, working either on problems of hydrology or atmospheric physics, most probably with regard to the Western Canadian Arctic.

**Eyjolfur (Leo) Yoshinaka, VA3EBI**  
**Alexandria, Ontario**  
**Carleton University**

I am a second year student at Carleton University and my degree program is a BSc Honours Physics (Experimental). I plan to continue with my Master's in Engineering or Master's of Science degree immediately after.

I am the founder and President of the Carleton Aerospace Astrophysics Radio Club (CA2RC; <http://www.ca2rc.ca>). In the first six months of operation the club implemented the CA2RC-SAT cubesat satellite project and established ground station VA3CZZ and implemented the eCA2RC STEM High School Cubesat Project for a high altitude balloon launch.

I plan to be involved with CA2RC projects for many years to come to ensure student members are adequately trained to sustain and grow the club. I hope to work in the Aerospace-Satellite Development and Communications / Radiation and Experimental Physics.

**Matthew Frederiksen, VE4MRF**  
**Winnipeg, Manitoba**  
**University of Manitoba**

I am a second year student studying Mechanical Engineering at the Price Faculty of Engineering at the University of Manitoba. I am working towards my Bachelor of Science degree in Engineering, hoping to specialize in the Aerospace option in the coming years.

I am active in two clubs at the school: the University of Manitoba Space Applications and Technology Society (UMSATS) and the University of Manitoba Amateur Radio Society (UMARS).

UMSATS meets from September to August to plan, build and launch a rocket. With the UMARS, we will be meeting periodically to practise using radios and

help the UMARS University Councillor with activities from time to time.

The University of Manitoba Amateur Radio Society (UMARS) gets together to practice using radios and we help the UMARS University Councillor with activities from time to time.

After completing this academic year my plan is to be working in the field as an engineer through the Co-op/IPP program at the University of Manitoba.

I will be working there full time from May- September to get work experience as an engineer.

## **Previous Scholarships in 2023:**

**Hayden Walker, VE9WZ**  
**Sussex, New Brunswick**  
**Mount Allison University**

"I'm in my third year of a Bachelor of Science degree in Computer Science with a minor in Mathematics at Mount Allison University.

I obtained my Amateur Radio certification this summer, and wish to thank Bruce Robertson, VE9QR, for helping me get into the hobby. Outside of school and Amateur Radio, I am on my university's competitive programming team, I am an avid collector of calculators, and I host websites from a server in my basement."

**Tyson Laevens, VA3TYS**  
**Wasaga Beach, Ontario**  
**Georgian College Ontario**

"After graduating with a Police Foundations Diploma, I went back to Georgian College for my Honours Bachelors in Police Studies.

Upon graduating I'll begin applying to Police Services, Nuclear Security Teams and or Conservation work as I have a few different ideas for my career path. My interest in Amateur Radio came from my father's teachings of basic electrical theory and experience with electrical components at a young age and my mom's influence on me as she most definitely is a social butterfly."

**Nicholas Ficara, VA3NDF**  
**Ottawa, Ontario**  
**University of Waterloo**

"I'm currently in my second year of Software Engineering at the University of Waterloo, where I've had the pleasure of being part of

# Youth On The Air Camp 2024

## YOTA Camp 2024 | Halifax | July 7-12

**Attention all young Amateur Radio operators! YOTA Camp is back and better than ever!**

After the success of the YOTA Camp in Ottawa in July 2023, Radio Amateurs of Canada has teamed up with Youth On The Air Americas to bring YOTA back to Canada.



YOTA Camp 2024 will be held at the Mount Saint Vincent University campus in Halifax, Nova Scotia from July 7 to July 12. Modelled after the successful Youngsters On The Air program in Region 1 of the International Amateur Radio Union (IARU), this will be the fourth YOTA Camp in the Americas with past camps being held in Cincinnati, USA (2021 and 2022) and Ottawa, Canada (2023).

YOTA Camp is open to Amateur Radio operators between the ages of 15 and 25. A total of 50 campers will be accepted to this year's program, an increase from last year. Don't miss out on this incredible opportunity! Come to YOTA Camp and we'll teach you all kinds of cutting-edge technology that can be used with Amateur Radio and connect you to other young operators and mentors in North, Central and South America. Through this program, young Amateurs will learn and practise essential skills taught through STEM principles such as electronics and radio wave propagation. The program will also prepare young Amateurs to contribute during emergencies and provide numerous opportunities in their own communities and future careers.

Are you already an expert? We are seeking young Amateurs who are willing to take their knowledge to the next level and share their past experiences with other young Amateurs. The camp will primarily focus on building strong relationships with peers and mentors, as well as developing new radio skills. Campers will operate a special event station featuring cutting-edge HF and VHF/UHF radios and a wide array of antennas that many only dream of using.

Applications are now being accepted! Applications submitted by January 15, 2024 and first-time attendees will be given priority. We will accept applications through May 31, 2024. The application process is free. The cost of the camp is \$100 USD plus transportation to and from the Mount Saint Vincent University campus. The \$100 USD fee will not be payable until after acceptance. Should a potential camper not be able to afford the fee, they may apply for a scholarship or waiver.

**Sponsorship:** This is an excellent opportunity for Amateur Radio clubs to help build the leaders of tomorrow. Radio Amateurs of Canada is also pleased to introduce the new "Send A Youth to Camp Campaign" which will run from February 1 to June 1 in which proceeds collected will be disbursed to assist campers with travel expenses. More information will be available in January on the RAC website.

**Important:** YOTA Camp 2024 organizers will provide updates on our website and through social media if there is any impact on the camp such as the need to reschedule.

For complete details about the camp and/or to sign up for updates by email, please visit the camp webpage provided below or contact [yota2024@rac.ca](mailto:yota2024@rac.ca).

For additional information, please contact Camp Director Neil Rapp, WB9VPG: [director@youthontheair.org](mailto:director@youthontheair.org)

YOTA Camp 2024 – <https://youthontheair.org/halifax2024/>

YouTube: <https://www.youtube.com/@yotaregion2>

UWOOrbital, a design team with an exciting mission: launching a satellite equipped with an Amateur Radio selfie service. You make a request with coordinates attached, and we will take a picture of you from space and send it down over UHF SSTV!

Beyond this exciting project, I'm building an automated QSL card sending software where you can send cards directly to your contacts. You can find more information on my website at <https://va3ndf.com/>."

**Michael Cutts, VA3UTT**  
Etobicoke, Ontario  
Humber College

"I am the Institute of Electrical and Electronics Engineers (IEEE) Student Branch Chair at Humber College.

For the past two years I have held many workshops for the students in Microcontroller Hardware and Software, Women in Engineering, Computer Programming, IEEEExtreme programming competition challenges, Smart City and an international Amateur Radio Study Group. I find helping the students is rewarding for me. I would like to gain employment in the telecommunications industry. I have a special desire to work with radio equipment and to track down radio jammers."

**Jared Thivierge, VE3GT**  
Kingston, Ontario  
St. Lawrence College

"I am enrolled in my first year of the Instrumentation and Control Engineering Technician program at St. Lawrence College. I am enjoying basic circuit building and electrical theory. In addition I am also having fun with all the devices and instruments we have at our disposal in our labs.

I do a lot of reading and crafting (crochet, mini-painting, bracelets) as well as cooking. I like computers and problem solving, and have taken part in local radio nets with my late grandfather's (Larry Thivierge, VE3GT) handhelds that were passed to me."

### Scholarships in 2024

Congratulations to all of the 2023 RAC Scholarship recipients! Applications for the 2024 scholarships will be accepted until September 15, 2024.

The scholarship application can be found at: <https://rac.ca/grant-information/scholastic-grant-application>



# DXCC in 40 Days with 4 watts!

Rick Williams, VE7TK – <https://www.ve7tk.ca>

I recently assembled the latest HF QRP transceiver kit from QRP Labs in Turkey (<http://qrp-labs.com>). Over the last few years I have built several of their kits, including a single band CW transceiver and 50-watt linear amplifier, a signal generator, a couple of clocks and several GPS units. I have always found their kits to be well designed, well documented and well supported by Hans Summers, G0UPL.

The latest kit is the QMX, a 5-band, multi-mode QRP rig. The transceiver covers 80, 60, 40, 30 and 20 metres and currently operates on CW and digital modes including FT8 and FT4 with plans to include SSB as the firmware develops. Like all QRP Labs kits the surface mount components are already on the board when it is shipped. The kit builder still must solder all the through-hole components, as well as wind the toroids and transformers. Some experience at kit building and a level of soldering skill is needed. Above all, the manual needs to be followed accurately step by step.

You can also follow Hans Summers' instructions on YouTube at:

[https://www.youtube.com/watch?v=pBZ\\_SXO-LIM](https://www.youtube.com/watch?v=pBZ_SXO-LIM)

My QMX transceiver kit arrived in late August and I built and tested it over four evenings. The kit included several carefully packaged bags of components, a single printed circuit board (PCB) and an optional case. The single PCB must be carefully scored and broken into a main PCB, 5-volt power supply, 3.3-volt power supply, a control board, a display board, two spacers and, wait for it, a QRP-Labs key fob.

The kit build includes winding all the transformers, low-pass filter inductors, installing the through-hole parts and connectors. The builder must decide if the unit will be powered by a 9-volt or 12-volt power source. I chose a 12-volt supply and the QMX means 12 volts not 13.8 volts!

Figure 2 shows the layout of the completed main board – with both power supply boards, behind the DC jack plugged into it.

The control board and display board plug into the main PCB (Figure 3).

The “nested” assembled boards were installed into the optional case and the little rig was ready for testing.

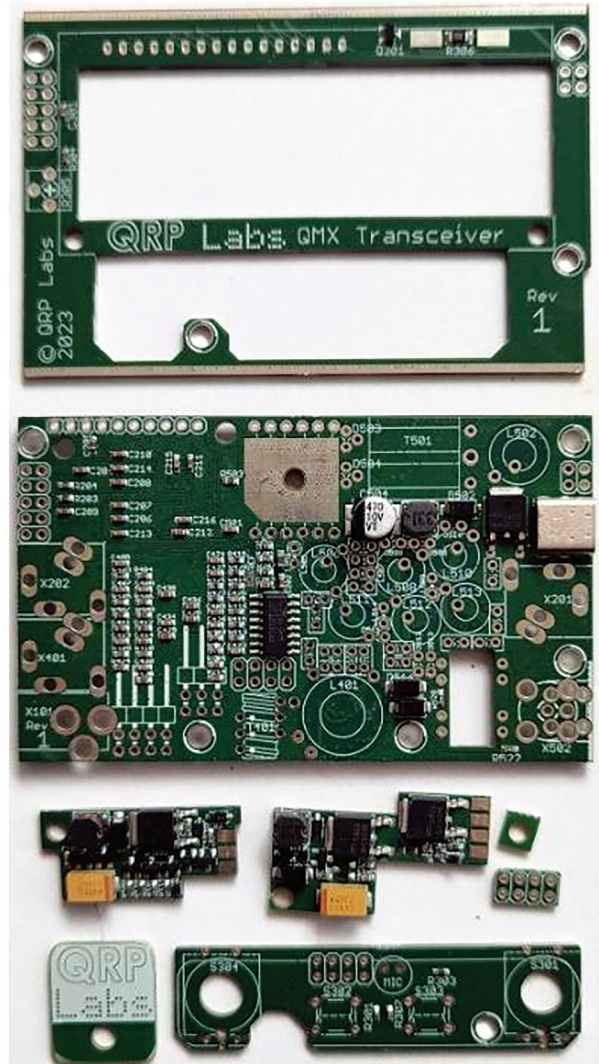

Figure 1: Printed Circuit Board (PCB).

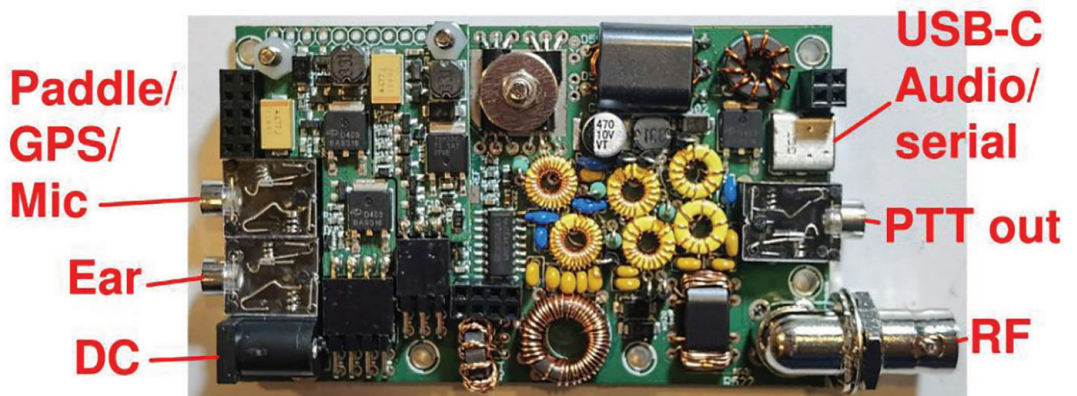

Figure 2: Ports

All that is needed to implement the digital modes and update the firmware is a USB-C to USB-A cable. An electret mic, which is included with the kit, can be soldered into the control board.

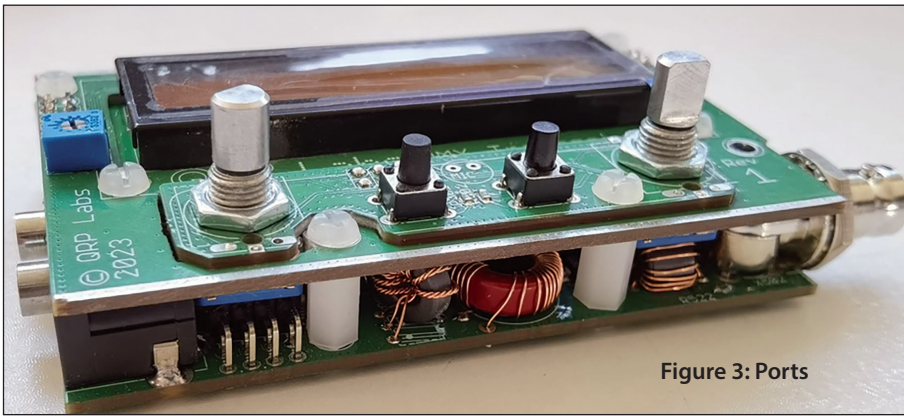

Figure 3: Ports



Figure 4: Assembled

Figure 5 below: DXCC list. Stations in bold have been confirmed via Logbook of The World.

#	DXCC	Call	#	DXCC	Call	#	DXCC	Call
1	Alaska	KL7VX	34	Estonia	ES5QA	67	Peru	OA4DPM
2	Angola	D2UY	35	European Russia	RD4A	68	Philippines	DV1UAR
3	Anguilla	VP2ETE	36	Finland	OH6PP	69	Poland	SP9W
4	Antarctica	VP8/UW5EHR	37	France	F4EXC	70	Portugal	CT1GTI
5	Argentina	LW2EY	38	French Polynesia	TX6D	71	Pples Repub China	BG2CPT
6	Asiatic Russia	UA0ZFW	39	Germany	DK7ZT	72	Puerto Rico	KP4B
7	Australia	VK1AO	40	Ghana	9G5AR	73	Repub Korea	DS1TUW/2
8	Azores Islands	CU3HN	41	Greece	SV8DCY	74	Repub S. Africa	ZS6ZA
9	Barbados	8P6PD	42	Greenland	OX3LX	75	Reunion Island	FR4OP
10	Belarus	EW8W	43	Guadeloupe	FT5GP	76	Romania	YO4NF
11	Belgium	ON2BCB	44	Guam	WA0OI	77	Samoa Islands	5W1SA
12	Belize	V31DL	45	Hawaii	WH6S	78	Scotland	GM4SJB
13	Bosnia-Herzegovinia	E74K	46	Indonesia	YC8RDG	79	Senegal	6W/IV3FSG
14	Brazil	PY5XT	47	Italy	IK5PWQ	80	Serbia	YT3PL
15	Bulgaria	LZ2KTS	48	Jamaica	6Y5PW	81	Singapore	9V1YC
16	Canada	VA5KEN	49	Japan	JA9ELE	82	Slovenia	S58WW
17	Canary Islands	EH8SDC	50	Kenya	5Z4VJ	83	Spain	EB2AM
18	Cayman Is.	ZF1EJ	51	Kuwait	9K2YM	84	St. Helena	ZD7MY
19	Ceuta & Melilla	EA9ACR	52	Latvia	YL3CW	85	St. Lucia	J68HZ
20	Chile	XO1KK	53	Lebanon	OD5KU	86	St. Vincent	J88IH
21	Colombia	HK3W	54	Madeira Island	CT3MD	87	Swains Island	W8S
22	Costa Rica	TI7ORC	55	Malawi	7Q7EMH	88	Sweden	SE2T
23	Croatia	9A9TT	56	Marshall Islands	V73AH	89	Switzerland	HB9HSJ
24	Cuba	CO2AV	57	Martinique	FM4SK	90	Taiwan	BX6ABC
25	Curacao	PJ2MAN	58	Mexico	XE2DDA	91	Thailand	HS0ZOY
26	Czech Republic	OK1FAK	59	Nauru	C21TS	92	Trinidad & Tobago	9Y4DG
27	Denmark	OU4N	60	Netherlands	PD5MVH	93	Tristan de Cuna	ZD9W
28	Dominican Republic	HI8MDQ	61	New Caledonia	FK8HM	94	Tuvalu	T22T
29	East Malaysia	9W8ZAL	62	New Zealand	ZL4KYH	95	Ukraine	UR3LM
30	Ecuador	HC5EG	63	Northern Ireland	MI0SAI	96	Uruguay	CX8FB
31	El Salvador	YS1CH	64	Norway	LA8ENA	97	USA	K1RH
32	England	G3ZQH	65	Panama	HP1DAV	98	Venezuela	YV5DRN
33	Equatorial Guinea	3C3CA	66	Paraguay	ZP6LMR	99	Vietnam	XV9R
						100	Wales	MW0ZZK

The first thing you'll notice is just how small this little rig is. It easily fits into your hand!

I cautiously powered up my new QMX and there were a couple of glitches. In all cases the problem was poor soldering by the builder – me! The PCBs are six-layer and on the interconnection from the main board to the control board I had applied insufficient heat to a ground connection on an 8-pin header. An easy fix and so I loaded the firmware and put it on the air on 20 metres with a couple of CW contacts.

Next I thought I'd try FT8 with a whopping 3.3 watts to a 3-element SteppIR on 20 metres! After a few tweaks I was able to push the output to slightly more than 4 watts and I began to chase DX on 20m in earnest!

The little rig was amazing. Between September 1 and October 10 (40 days), I was able to work 100 DXCC entities, 95% FT8, with 4 watts! You can see my DXCC list in Figure 5. Stations in bold have been confirmed via Logbook of The World (LoTW).

Over the same period the firmware has been updated several times and options protecting the rig from over-voltage and high standing wave ratio (SWR) are now included.

In summary, I love this little rig! The software defined radio (SDR) hears well, the CW QSK (break-in) is smooth, and the output from the built-in sound card is clean! You get a lot of bang for the buck. The rig, optional metal case and FedEx shipping and handling cost approximately \$140 USD!

What's next? QRP-Labs has announced that a 20 through 10 metre version of the QMX is now available. I have already placed my order!

*Rick Williams, VE7TK/VE7ASR, is an avid DXer and occasional contester. First licensed in 1987, he is a member of the ARRL DXCC Honor Roll with 338 of the current 340 DXCC entities confirmed. In addition, Rick is an ARRL authorized DXCC Card Checker and a member of the BCDX Club, the ORCA DX and Contest Club and the Island HF Club.*





Keith Baker, VA3KSF/KB1SF  
kb1sf@yahoo.com

# Amateur Radio Satellites



An artist's impression of what Low Earth Orbit (LEO) may soon look like if the growing orbital debris problem is not solved. (Courtesy: Shane Rebenschied/Scholastic Scope)

## Introduction

In my last few installments of the column, I've been highlighting the many ways one can get in on the fun of operating on our fleet of Amateur Radio satellites as well as highlighting the work of various satellite-oriented organizations that continue to build and launch them. However, at present, there is a looming regulatory problem that threatens to *seriously* curtail Amateur Radio's efforts in space unless and until it is adequately addressed.

The issue is colloquially referred to as "space junk". And, as more and more pieces of this stuff are launched into orbit (and don't rapidly decay or are relatively quickly de-orbited) eventually it will become ever more dangerous to launch and operate our Amateur Radio satellites (or, for that matter, any satellite or a space station) operating there for fear of inviting catastrophic on-orbit collisions of those precious cargoes. Clearly, something must be done to mitigate this looming threat.

And if you think this issue has nothing to do with Amateur Radio, think again. If Amateur Radio satellite providers like AMSAT simply ignore the problem, various government regulatory agencies throughout the world have now been given the power to completely prohibit such Amateur Radio related organizations from building and launching future Amateur Radio satellites *altogether*.

Fortunately, AMSAT's volunteer engineers are now well aware of this looming regulatory problem and are currently working on some innovative solutions to address it.

## The Looming Problem of "Space Junk"

### What is "Space Junk"?

As I've said, orbital debris (the fancy term for "space junk") is now becoming a big issue in space. But back when the very first Amateur Radio satellites were launched in the early 1960s it wasn't. Still, one would think that space remains a pretty big place and that space junk wouldn't be a big issue. However, today, around 7,500 satellites are operating at altitudes below 2,000 kilometres – the upper limit for Low Earth Orbit (LEO). More than a third of those were launched in the past two or three years and there are many more to come. Launches by private companies such as SpaceX and Amazon are already swelling the number of satellites in LEO to more than 45,000.

Satellites represent only a small fraction of the objects now whirling around our planet. The North American Aerospace Command (NORAD) is currently tracking some 27,000 pieces of orbital debris larger than a tennis ball. This includes such things as discarded launch vehicles and parts of old spacecraft, to lost tools and jettisoned bags of garbage from space stations. Added to that tally are an estimated *one million* pieces of debris larger than a marble, and a further *330 million* between 1 mm and 1 cm in size!

All these objects are travelling at 25,000 km/h (or 7 km/s) and often in a variety of intersecting orbits. At that speed, even tiny pieces of debris can do a

significant amount of damage to a satellite – or a human inside an orbiting space station.

Indeed, the first ever collision between two, actually catalogued space objects was detected in LEO back in July 1996 and it involved a satellite based on one of AMSAT-UK's initial UoSAT designs. After one year of perfect operation in space, controllers at the Space Mission Control Ground Station at the Surrey Space Centre in the United Kingdom observed a sudden change to the attitude dynamics of their Cerise microsatellite when it started rapidly tumbling end-over-end in its polar earth orbit.

After an initial investigation, a collision with a piece of space debris was suspected. Subsequent analysis suggested the debris piece may have been part of the defunct 18208 1986-19RF satellite. The collision apparently tore off a 13-foot portion of Cerise's gravity-gradient stabilization boom, which left the satellite severely damaged. Fortunately, controllers at Surrey Satellite Technology Limited (SSTL) – a spinout company from the University of Surrey in England – were eventually able to regain control of the satellite using its onboard electromagnetic stabilization system.

Unfortunately, subsequent collisions or explosions since then have only added to the problem. When Russia successfully tested an anti-satellite missile in

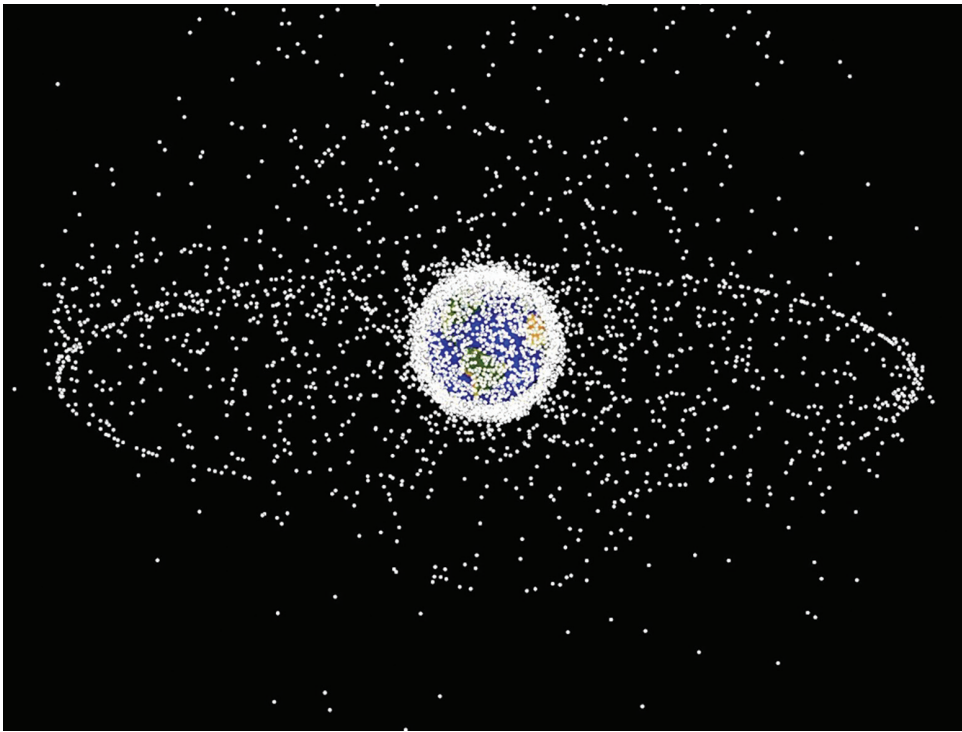

Figure 2 (above): A computer-generated image of objects in Earth orbit that are currently being tracked. Approximately 95% of the objects in this illustration are orbital debris – that is, no longer functioning satellites. The larger population of objects over the northern hemisphere is due mostly to Russian objects in high-inclination, high-eccentricity orbits. (Courtesy: NASA)

Figure 3 (below): Of the known and tracked space junk, 70 percent of it is in Low Earth Orbit, which extends about 1,250 miles (2,000 km) above the Earth's surface. The debris field shown in this image is an artist's impression based on actual data. (Courtesy: Science Media Centre Espania)



November 2021, it created 1,500 *more* pieces of trackable debris as well as hundreds of thousands of smaller pieces. In the immediate aftermath, crewmembers aboard the International Space Station (ISS) had to take refuge in their docking capsules in case they needed to make a quick getaway. The ISS itself has had to move out of the way of space debris over 25 times since 1999.

Fortunately, most of this space junk eventually de-orbits and burns up in the atmosphere. But, there's still enough of it that remains in orbit to cause concern, so much so that many governments around the world are now taking regulatory action. And, if they aren't taking such action at the moment, many soon will be.

### The Regulatory Issue

As I've noted in a previous column, there are actually two internationally regulated Amateur Radio services. The one we are most familiar with (and operate in) is the Amateur Radio Service. But there is a second one – the *Amateur Satellite Service* – that was specifically conceived by the International Telecommunication Union (ITU) to regulate Amateur Radio's efforts in space. These regulations pertain primarily to the building, licensing, launching and operating of our Amateur satellites on orbit, and are the regulations organizations like AMSAT must adhere to when building, launching and operating their satellites.

Up until very recently, the USA's Federal Communications Commission (FCC) allowed AMSAT-North America's satellites to carry a US licence without also carrying some form of de-orbiting capability if the satellite would de-orbit and burn up in the atmosphere *on its own* within 25 years. However, those FCC rules were recently changed so that now any new satellite that is built and launched with a US license must de-orbit only *five years* after its "end of life".

Clearly, this now creates a very difficult problem for satellite builders trying to predict a planned satellite's on-orbit lifetime, the least of which is determining just what "end of life" really means. For example, our venerable AMSAT AO-7's re-awakening after several years of dormancy back in the mid-1990s is a clear example of the problem.

What's more, the FCC has pending requirements that satellite organizations be able to de-orbit a US-licensed satellite "on command". And as if that were not enough, AMSAT's leadership and volunteer engineers are also beginning to hear regulatory rumblings that AMSAT may soon be required to maneuver one of their newly launched satellites to avoid a "conjunction event", that is... a collision.

And, lest you think that this is all just more bureaucratic nonsense, it appears the FCC is absolutely serious about enforcing their new regulations. Indeed, for the very first time, the FCC issued a hefty fine to the USA's commercial Dish Network because they were not able to move their defunct geostationary EchoStar-7 satellite fully into its intended disposal orbit. Dish was supposed to move it 186 miles further from the Earth, but it only reached 76 miles because the satellite ran out of fuel. This fine is clearly a harbinger of things to come.

## So, What Is AMSAT Doing?

Recently, Jonathan Brandenburg, KF5IDY, AMSAT's Assistant Vice-President for Engineering discussed some recent trends in propulsion systems for small satellites – the kind that AMSAT currently builds and launches – at AMSAT's 2023 Annual Space Symposium held in late October in Dallas, Texas. In his talk, Jonathan outlined some of the techniques he and his volunteer experimenters are now exploring for future AMSAT satellites.

To address the problem, he noted there are actually three issues that must be addressed. "We need three things: A GNSS (Global Navigational Space System), an ADCS (Attitude Determination and Control System) and a thruster. A GNSS is needed to determine the exact position of the satellite. We have a current experimenter project in progress for this."

Jonathan also noted that, "We have to be able to accurately determine the position and orientation of the satellite so we know that any onboard thrusters are oriented in the correct direction when they are fired. We are currently planning to fly an ADCS on our GOLF-TEE satellite that is now estimated to be launched in the second quarter of 2025."



Jonathan Brandenburg, KF5IDY, AMSAT's Assistant Vice-President for Engineering, holds up a model of the 3D structure of half of the GOLF TEE satellite that controls the power and the attitude at his presentation at AMSAT's 2023 Annual Space Symposium. Courtesy AMSAT via YouTube at: <https://www.youtube.com/watch?v=pcO4-h7bbxs&t=465s>

Jonathan also discussed what AMSAT is doing to investigate small satellite thrusters. He said, "We have a new experimenter project ongoing for small satellite thrusters because there are many different types of thruster systems that might work for our purposes."

Some of the examples he discussed include solid motor thrusters (which are very powerful), so-called "hall effect" thrusters which are popular (but are also large and power hungry). However, such thrusters are also very reliable. And then there are so-called "electrospray" thrusters. Electrospray thrusters are both relatively simple to build and operate, but they are also inexpensive. The propellant for these systems can be solid or a liquid, which melts down quickly and is then accelerated out of the nozzle using an electric field. It is an affordable (and moderately simple) technology.

Another technique Jonathan mentioned is "pulsed plasma/vacuum arc" thrusters that have the advantage of being a very, very simple and affordable technology. They use an electric arc to ablate the material that actually then becomes the fuel. The fuel material can be a light metal or a high technology plastic. He also noted that, "We've recently acquired a

demonstration kit for a pulsed plasma type thruster. We are in the early stages of engaging our volunteers to perform an in-depth analysis of this thruster as part of our investigation to determine which thruster is the most appropriate for AMSAT."

Jonathan's presentation at the AMSAT Annual Space Symposium is available on YouTube at the link provided below. His presentation includes a short demonstration of a pulse plasma type thruster made by Hypernova Space. The demonstration also includes firing the thruster, the control software, and some of the output data.

You can find it at: <https://www.youtube.com/watch?v=pcO4-h7bbxs&t=465s>

## Wrap Up

That's all for this installment. In future columns, I'll continue to shine the spotlight on Amateur satellites that are currently on the drawing boards as well as satellites still in orbit. In the meantime, you can obtain the very latest Amateur satellite status from the AMSAT website at: <https://www.amsat.org/status/>.

And, as always, I very much look forward to meeting you on the birds!



# COAX PUBLICATIONS INC STUDY GUIDES

## Canada's Most Popular Amateur Radio Study Guides!

For over 14 years Coax Publications has produced the best study materials for students studying for their Canadian Basic or Advanced Qualifications in Amateur Radio. We cover all of the information required for the ISED exams. Our books provide valuable context to what you are learning and are used by the RAC online classes and most Amateur Radio clubs. The price of the books includes lifetime access to the Student Success Pages and *Ask the Professor* help pages on our web site. Students – you will want to keep these books for reference after you pass your course!

### Canadian Amateur Radio Basic Qualification Study Guide

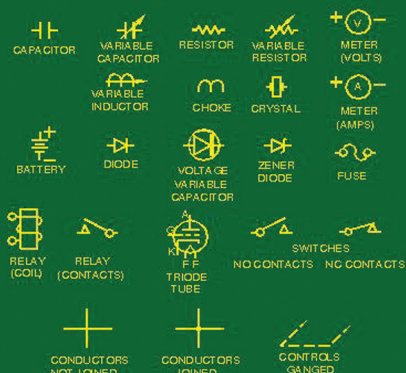

Ninth Edition

Includes Unlimited Access To Student  
Success Pages On Our Web Site!

Coax Publications Inc

\$49.95 + shipping and taxes

### We Want You To Be Successful!

#### Canadian Basic Qualification Study Guide

Designed to teach you everything required to earn your Basic Qualification. Covers all material in the ISED Question Bank with additional material for context.

The new 5th printing now available updates some material and adds information about the 630 metre and 60 metre bands.

Still includes unlimited access to our Student Success Pages online. Now printed on opaque 50 lb stock, 8½" x 11" with rugged lie-flat binding.

#### Canadian Advanced Qualification Study Guide

New for 2023, this new 3rd printing updates some sections that were a bit ambiguous, corrects all known errors in previous printings, and replaces some parts of Section 1.5 related to resonant circuits.

For the student who has prior operating experience and wants a challenge, the Advanced Qualification is the next step.

Now printed on opaque 50 lb stock, 8½" x 11" with rugged lie-flat binding.

### Canadian Amateur Radio Advanced Qualification Study Guide



Includes Unlimited Free Access To The  
Student Success Pages On Our Web Site!

Second Edition

Coax Publications Inc

\$49.95 + shipping and taxes

Clubs: Volume discounts are available for quantities of 7 and 25 books.

Prices do not include shipping and taxes; these will be added when you place your order depending on where you live.

#### Canadian Basic Instructors' Guide

Basic Instructors' Guide: \$19.95, for the first time instructor, this downloadable file contains suggestions for classroom activities, all of the drawings and photos from the Basic Guide in a form that can be printed or projected, class plans, and other materials, divided by chapter.

#### Student Success Pages

Student Success Pages: \$14 – for those who are studying from other sources, it provides access to our learning support features, including *Ask the Professor*. Lifetime access is already included when you purchase a book.

All materials are produced and printed in Canada:  
Coax Publications Inc, Newmarket, ON, Canada

Order From Our Web Site: <http://www.coaxpublications.ca>



**Allen Wootton, VY1KX**  
 Box 21217 | Whitehorse, Yukon  
 vy1kx@myrac.ca

## Reverse Polarity

Occasionally I have connected batteries or power supplies to equipment backwards. I suspect that I'm not the only one that has done this; it's an easy mistake to make. Fortunately, there are some things that can be done to prevent the equipment damage that can result from a momentary surge of reverse polarity current caused by this careless mistake. In this column I will outline some ways to do this.

### Mechanical Methods

Power connectors designed such that they can be inserted in only one way provide some protection against reverse polarity connection. Examples are the Anderson "Powerpole" connectors and the connectors on 9-volt batteries. Though it applies to AC, the different size of the two prongs of a 120-volt plug are another example; in this case ensuring that the "hot" and neutral connections are appropriately connected to an appliance.

In each of these examples, the assumption is that the wires between the power source and connector – or between the connector and equipment – are attached correctly. If, for example, wires to Powerpoles are accidentally connected backwards to a power supply, the mechanical protection of the Powerpoles is lost. Similarly, although the battery terminals of 9-volt batteries are different, it is easy to momentarily touch the connector in opposite polarity – or to wire the connector itself backwards to the circuit. Clearly, while these mechanical methods to prevent reverse polarity

# "QUA – A Topical Digest"

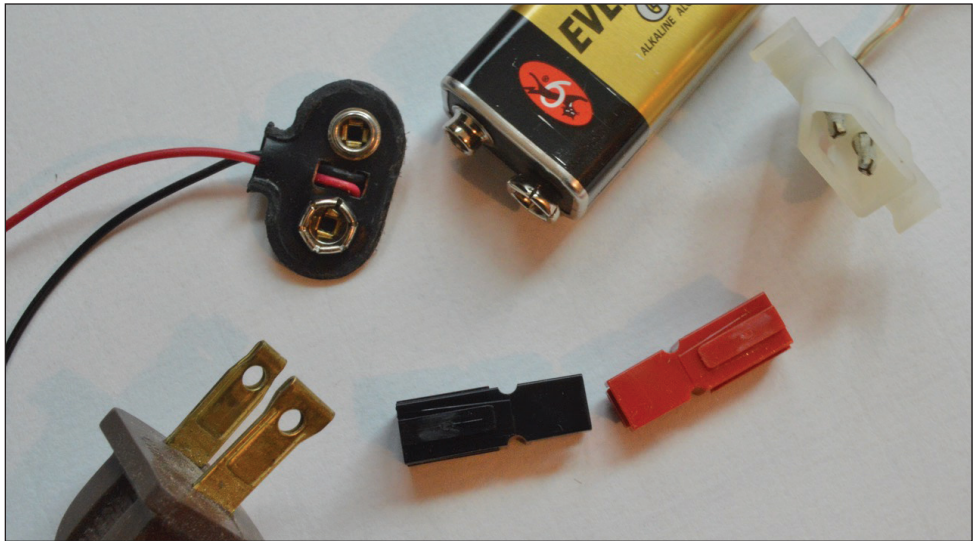

Figure 1: Anderson "Powerpoles", 9-volt battery connector, 120-volt polarized plugs and innumerable odd-shaped connectors provide some measure of mechanical reverse polarity protection. Nine volt battery connectors are not a great example, however, because the connections are exposed at both battery and connector and so can touch momentarily with the wrong polarity.

connection can be helpful, some circuit modifications that also provide electronic protection can be really beneficial.

### Diode Protection

The simplest electronic protection circuit addition uses a diode connected as shown in Figure 2. This simple circuit addition is great for low power circuits that can tolerate a voltage drop across the diode of about 0.6 to 0.7 volts. For a low power circuit the diode could be a 1N400X (where X = 1-7), for example. It is not very good for high power circuits, however, because the diode's voltage drop increases with increasing diode current. This current multiplied by the diode voltage drop is power wasted as

heat in the diode and may cause its overheating. If used to protect the circuitry of a transmitter operating from a 12-volt power supply, a diode connected in this way will, in fact, leave 11.3 volts or less for the equipment.

Because Schottky diodes have a lower forward voltage drop, they are sometimes suggested as alternatives to regular diodes for reverse polarity protection. I made some measurements of the diode drop for several different types of 1-amp rated diodes. My results are shown in Table 1. There you can see that as the load resistance decreases – and the current increases – the voltage drop across the diode increases. You can also see that the

Table 1: Diode voltage drop measurements for a selection of diodes.

Load Resistance [ $\Omega$ ]	Diode	Diode Voltage Drop [V]	Load Voltage [V]
15	1N5061	0.85	13.1
15	1N4004	0.87	12.9
15	?	0.81	13.2
15	Schottky MBR1100	0.72	13.3
25	MBR1100	0.66	13.3
115	MBR1100	0.47	13.5
15	Bridge Rectifier RBV604	1.59	12.47

The third diode tested was of unknown type salvaged from equipment. From its size I estimated its forward current rating to be several amperes. The rest of the individual diodes have a 1 ampere forward current rating. The bridge rectifier has a 6-amp rating.

voltage drop across the Schottky diode is less than that of the regular diodes but not hugely so. This smaller voltage drop is important for some circuits in which Schottky diodes are suited but I don't think the difference is particularly significant for reverse polarity protection.

### Diode and Fuse Protection

Diodes can be used in conjunction with a fuse to provide reverse polarity protection. Circuits of this type are shown in Figure 3. As you can see there, if the power supply polarity is correct no current will flow through the diode and there will be no diode voltage drop between the power supply and the equipment being powered. However, if the power supply is connected backwards, the diode current will be very large and, if the fuse is sized appropriately, it will disconnect power from the circuit.

The advantages of these circuits are simplicity and the direct connection between power supply and equipment with only a small voltage drop across the fuse. The circuits have two major disadvantages, however. The first is the result of the time taken for the fuse to respond in the event of reverse polarity. Even a short pulse of reverse polarity current during the time when the fuse remains intact may cause significant damage to equipment. The second problem is that the circuit depends on both the fuse and the diode. If the power supply is connected backwards, significant current will flow through the diode until the fuse blows. It is important that the diode is sized appropriately to handle this current.

For example the diode in Figure 3(a) should have a current rating higher than (at least 2X) that of the fuse, and the fuse rated about 20% greater than the current required by the equipment. In the power supply chapter of my 2018 edition of the *ARRL Radio Amateur's Handbook* it suggests that a positive temperature coefficient resettable (PTC) fuse could be used as shown in Figure 3(b).

I made some measurements on this PTC fuse type of circuit, first with a 13.8-volt power supply and then with a 12-volt car battery. My results are shown in Table 2. The measurements listed there show similar results for the two different power

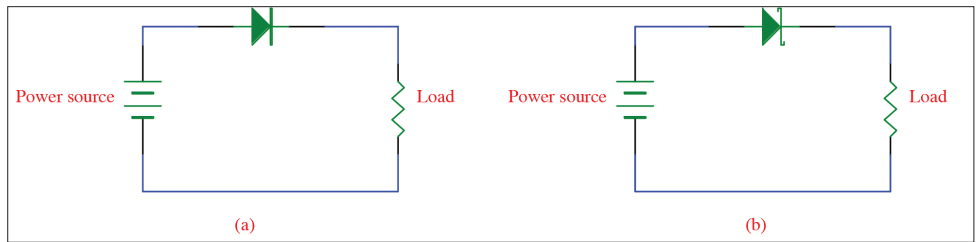

Figure 2: In (a) a regular diode is used to provide reverse polarity protection. A Schottky diode is used in (b). In both examples the power source could be a battery or power supply.

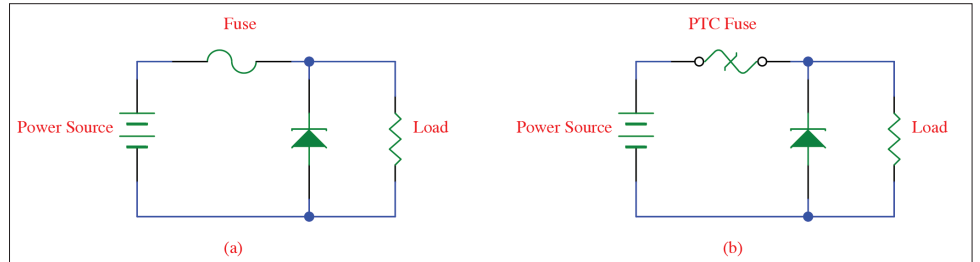

Figure 3: Diode and fuse protection circuits.

Forward PTC Fuse V drop	Forward V Load	Reverse PTC Fuse V drop	Reverse V Load
0.11 V	13.85 V	13.4 V	0.75 V
0.11 V	12.20 V	11.8 V	0.78 V

Table 2: The first row of the table shows the measurements made with a 13.8-volt power supply and the second row are those from a test with a 12-volt car battery.

sources; however, the initial response in the reverse polarity situations was quite different.

When the power supply was connected backwards, the load voltage gradually decreased from about 0.9-volt to that shown in the table while the voltage drop across the PTC fuse increased from about 0.5-volt up to 13.4 volts. This took about 12 seconds. I assume that this behaviour was due to current limiting in the power supply.

In contrast, when connected backwards to the battery, the 11.8-volt drop across the fuse and the 0.78 volts across the load seemed to occur instantaneously. There was no current limiting in this situation! In both reverse polarity tests the PTC fuse became very hot after a few seconds.

PTC fuses are made by embedding carbon particles in a plastic polymer that expands when heated. The expansion moves the carbon particles farther apart until current conduction through the fuse almost ceases. When the PTC fuse cools it returns to its conductive state.

The behaviour I observed matches what I would expect from these components. I understand that PTC fuses are used in many consumer electronic devices – often in tiny surface mount form in places where a regular fuse would be difficult or impossible to replace – but I don't think I would use them as a protective component where significant power is involved.

### Protection Provided by Diodes in a Bridge Configuration

In Figure 4 I have drawn the circuit of a diode bridge just like those used in full wave power supplies but now connected to a DC power source. This bridge circuit has a very nice feature: it doesn't matter which way the power is connected at the input, the output will always have the correct polarity. You can see why by tracing the current direction from the marked positive input of Figure 4 to the negative terminal. If you reverse the input terminals you will see that the conducting diodes change but not the output polarity. Unfortunately, this circuit has the disadvantage that regardless of how the input is connected there are two diode

voltage drops between input and output. This means that a 12-volt input will result in an output of 10.6 volts or less, depending on the load.

I measured the voltage drop for two different bridge rectifiers that I had salvaged from old equipment. Both were intended for several amperes of current. The voltage drop results I obtained for one of these bridge rectifiers when connected to a 15-ohm load resistor are shown in Table 1. The results for the other bridge rectifier were very similar.

### Bipolar Junction Transistor Protection

Whereas the electronic protection circuits discussed so far have the advantage of simplicity, they all have the disadvantage of some voltage drop between the power source and the equipment (even though it is small for the diode and fuse combination). In some cases bipolar junction transistors (BJT) can provide reverse polarity protection with a smaller voltage drop than all but fuse/diode method.

Two circuits are possible: NPN or PNP. These are shown in Figure 5. You will notice there that I have specified a 5-volt power supply in these examples. This is because the limitation of the BJT is the emitter-base breakdown voltage. For the common 2N3904/2N3906 NPN/PNP transistors this is 5 or 6 volts, depending on which manufacturer's data sheet is checked. For the power transistor pair 2N3055/MJ2955 it is only 7 volts. A reverse connection with a higher voltage would very likely destroy the transistor.

I tested the PNP version of this circuit using a 2N3906 transistor, a 5-volt supply and a 51-ohm load resistor. Since there should only be a small voltage drop across the transistor there should be nearly 5 volts across the resistor and a current through it of nearly 100 mA. For a transistor beta of 100, a base current of 1 mA would be sufficient.

Since the emitter-base junction should have a voltage drop of about 0.7 volts, a base resistor of  $4.3/0.001 = 4.3$  Kiloohms would seem appropriate. However, as the collector current increases to substantial values in comparison to the maximum, a transistor's beta decreases. To compensate, the base current needs to be increased.

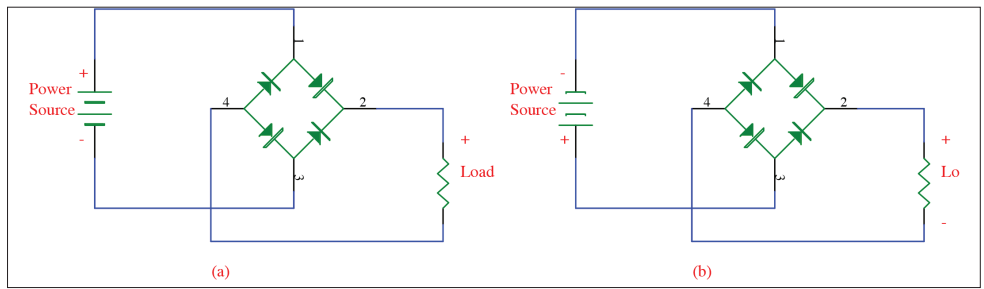

Figure 4: In (a), current flows from point 1 to 2, then through the load and from 4 to 3 back to the power source. In (b) current flows from point 3 to 2, through the load, and back to the power source from 4 to 1. In both cases the polarity at the load remains the same.

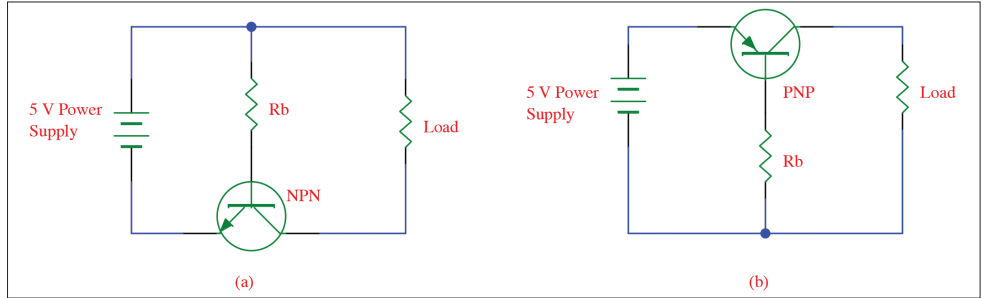

Figure 5. BJT used for reverse polarity protection. The NPN configuration shown in (a) does not permit a common negative between the power supply and the load. Circuit (b) is preferable for that reason, and also, because there the transistor acts as a switch in the positive lead. In both cases the base resistor  $R_b$  is chosen to provide sufficient drive to the transistor so that it is fully "on" when the polarity is correct.

Base Resistor [kΩ]	Transistor Voltage Drop [V]	Output Voltage {V}
3.9	0.91	4.07
1.0	0.28	4.70
0.5	0.20	4.78
0.3	0.18	4.80

Table 3: Transistor voltage drop and output voltage as a function of base resistance and base current.

You can see this in Table 3, in the increasing output voltage – and smaller transistor voltage drop – as the base current increases due to the decreasing resistance of the the base resistor.

From the results, I calculated that a base current of less than 2% of the collector current was sufficient to produce an emitter-collector voltage drop of about 0.2 volts. There was no output voltage if the polarity was reversed. For a low voltage (< 5 volts), low current supply (~100 mA), a transistor circuit could be a good choice for reverse polarity protection due to the low voltage drop across the transistor. The disadvantages are the need for constant base current, a maximum voltage limit imposed by the base-emitter breakdown voltage and a slightly increased circuit complexity.

### MOSFET Protection

Like BJTs, Metal Oxide Field Effect Transistors (MOSFETs) can be made in P or N types. They can also be enhanced or depletion types. The enhanced MOSFETs act like normally "on" switches whereas the depletion mode MOSFETs act oppositely, as normally "off" switches. It is the depletion mode MOSFETs that are suitable for reverse polarity protection. Possible circuits are shown in Figure 6.

Although P-channel MOSFETs are preferable, I used an IRF510 N-channel MOSFET for some tests because I had several available. The IRF510 has a fairly high resistance when conducting; there are many examples with  $R_{DS(on)}$  (ie, the conducting resistance) much less than its 0.54 ohms. For example, the P-channel

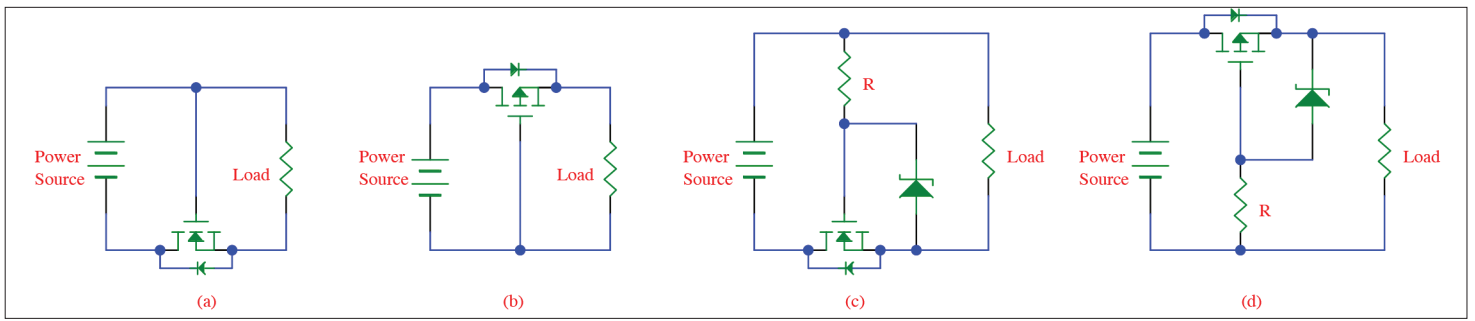

Figure 6: Circuits (a) and (c) use N-channel MOSFETs, (b) and (d) are P-channel MOSFETs. P-channel MOSFETs circuits are preferred because they switch the positive supply and allow a common ground between power supply and equipment. The Zener diodes in circuits (c) and (d) limit the gate-source voltage and prevents damage due to possible overvoltage. The Zener voltage should be a volt or so less than the maximum gate voltage. Resistor (R) is chosen to provide current within the operating range of the diode. If there is a possibility of sudden reversal of polarity its value should be low, in the 100 to 300 ohm range, so as to quickly discharge the gate. Otherwise larger values, 1 kilo ohm or more, can be used.

MOSFET IPB180P04P4L designed for reverse polarity protection has an on resistance of 2.6 milliohms when conducting 100 amps! It is available from DigiKey for about \$6.

For my tests I used the simple circuit shown in Figure 6 (a). The power supply voltage was 14.04 volts. My results for several different load resistances are shown in Table 4. As you can see there, as the load resistance decreased  $V_{DS}$  increased, as expected. When the polarity was reversed there was no measurable conduction.

I haven't included one other type of MOSFET circuit. This circuit uses a charge pump to raise the gate voltage of an N-channel MOSFET so that it can be placed in the positive power lead. At the expense of more complexity this takes advantage of the slightly lower "on" resistance of an N-channel MOSFET (compared to P-channel) while retaining the advantage of a switch in the positive lead.

An excellent "DigiKey" article on N-channel MOSFET reverse polarity protection circuits can be found at:

<https://components101.com/articles/design-guide-pmos-mosfet-for-reverse-voltage-polarity-protection>

### Electro-Mechanical Protection Circuits

Electro-mechanical protection circuits use a relay to provide reverse polarity protection. Two example circuits are shown in Figure 7. In both examples, diode D1 controls the flow of current

Load Resistance [ $\Omega$ ]	$V_{DS}$ [V]	$V_{Load}$ [V]
15	0.31	13.65
10	0.47	13.36
7.5	0.59	13.14
4.3	0.87	12.53

Table 4: Measured results for the circuit of Figure 6(a) using an IRF510 N-channel MOSFET. Although the power supply voltage remained constant, the sum of  $V_{DS} + V_{Load}$  decreased as the load resistance decreased. This was due to the increasing voltage drop in the test leads from the power supply to the circuit as the load current increased.

through the relay; diode D2 is a snubber diode to limit the inductively generated back electromotive force (EMF) of the relay coil. Although diode D1 will decrease the voltage applied to the relay coil by about 0.7 volts from that of the power supply, this difference should have no effect on the relay's operation. Relays will generally switch at voltages considerably less than the coil voltage specifications.

These circuits have some significant advantages for high current applications. A relay coil that operates on milliamperes can provide the switching power to control amperes of current through the relay contacts, and the contacts themselves have very low resistance so the voltage drop across them will be very small even at high currents. Relays are very reliable too. The main disadvantages are the continuous current needed for the coil and any switching time that could cause very brief reverse polarity. Circuit (b) eliminates both of these disadvantages.

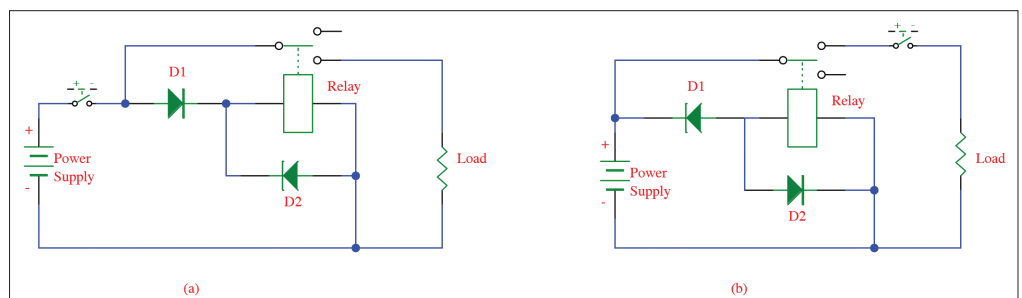

Figure 7: In circuit (a) the relay is energized if the power supply is correctly connected. The load current is supplied through the normally open relay contacts. With reverse polarity, diode D1 prevents current flow through the coil and the contacts open. Reverse polarity energizes the relay coil and the contacts open. In (b) the relay provides power to the load through the normally closed contacts which open if the power source is connected backwards. In this case the switch can be located after the relay, as shown, because with correct polarity, the diode D1 blocks current flow through the relay coil. Placed in this position, the switch allows the relay to respond before any power is connected to the load.

# RAC Regulatory Roundup

## Remotely-Controlled Stations

On several recent occasions, I have had questions from Canadian Amateurs about remotely-controlled stations ("remotes"). A "remote" is a station at a location somewhere physically different from the operator. These days, most remotes are controlled over an internet link using widely-available software.

Individual Amateurs and clubs across Canada and around the world are getting into remote operating. There are even a few private companies building remotely-controlled stations ("remotes") and renting time on them to qualified Amateurs. Controlling and operating a remote is often accomplished over the internet, but control by some kind of RF link is now being done with some remotes. Once upon a time, there were remotely-controlled stations operated over landline telephone links.

The technical challenges of setting up and operating a remotely-controlled station are significant. There are commercial, off-the-shelf (COTS) solutions for remotes, and some contemporary transceivers are designed with remote operation in mind. As good as current COTS equipment for remotes is, there are many technical challenges in setting up and operating a remote to ensure it is adequately controlled.

One absolutely essential remote station design parameter is that it must be possible to turn off the transmitter of a remote in the event that it causes harmful interference. Turning off an interfering transmitter is a lot easier when it's in your shack. If it's a few kilometres away, or across the country, adequate control is a major challenge.

Some Amateurs and clubs chafe at this restriction, often out of enthusiasm for the project. Who wants to have rules get in the way of something so interesting? I have had some pretty cranky reactions from some proponents of remotes and some pretty wild analogies. The rules are really quite clear.

### The Canadian Rules on Remotes

To establish or to operate a remote in Canada, you must hold an Advanced qualification. That is clearly laid out in "RIC-3 – Information on the Amateur Radio Service", a policy document published by the federal department of Innovation, Science and Economic Development Canada (ISED).

In section 4.5 of RIC-3, there is a list of restrictions for those holding Basic, Basic with Honours and Basic with Morse Code qualifications. Section 4.5.1 (Basic Qualification) states: "no remote control of fixed stations permitted regardless of medium used for control."

It further defines remote control: "Remote control is the ability to indirectly manipulate the technical parameters (i.e., bandwidth, emission type, output power, etc) of a radio by means of some intermediate medium. Operation through a repeater is not considered to be remote control."

Section 4.5.2 of RIC-3 makes it clear that one of the additional privileges of holding an Advanced qualification is "remote control of fixed stations, including the use of radio links."

### ISED Policy is Binding

Many have wondered about the validity of the requirement to hold an Advanced certificate. They note that there is no article in the Radiocommunication Regulations that limits who may operate a remotely-controlled Amateur station in Canada.

They also note a phrase in the preface of RIC-3 that states: "Radiocommunication Information Circulars (RICs) are issued for the guidance of those engaged in radiocommunications in Canada... It is important to note that these circulars have no status in law."

We should all understand that Amateur Radio in Canada is governed by a web of laws (the Radiocommunication Act), regulations (the Radiocommunication Regulations) and by ISED policy.



**Dave Goodwin, VE3KG**  
**RAC Regulatory Affairs Officer**  
**regulatory@rac.ca**  
<https://www.rac.ca/regulatory-advocacy/>

In my column in the March/April 2023 TCA (pages 20-23), I described our regulatory environment. I wrote then, and I will repeat now: "RIC-3 provides general information about the Amateur Service, including critical details about the differences in the privileges of people holding the Basic, Advanced and Morse Code qualifications. If you hold an Amateur certificate, you need to understand what's in RIC-3 to know some specific details about what the certificate does and does not permit you to do."

That policy is binding, even if it not explicitly expressed in regulations. To illustrate the point, the contents of every Basic and Advanced exam are clearly laid out in RIC-3. Those contents are not spelled out in regulations, but they are no less binding. A Basic Exam has to contain one question from each of 100 categories of knowledge. No more and no less. And the pass marks are equally clear, even if they do not appear in the Radiocommunication Regulations.

Remember that ISED can limit your privileges at any time should you be found operating outside the parameters of your level of certificate or in contravention of RICs, RBRs (Regulations by Reference), the Radiocommunication Act or the regulations. ISED can invoke the authority of the Minister to curtail your operations, your power, the frequencies on which you operate – in fact any aspect of your Amateur Radio activity. They would not do so without reason, but they still have this power.

RIC-3 is an official document which, among other things, differentiates the privileges we have based on our qualifications. RIC-3 clearly states that you must have your Advanced qualification to operate a remotely-controlled station. This limitation is based on the complexity of building up adequate means of controlling the remote transmitter and the fact you can change the operating parameters of the remote transmitter – frequency, power, mode, etc.

Amateurs may draw parallels between repeaters and remote control stations, citing how Basic certificate holders can operate a repeater. Both are complex to design and build, however users of a repeater don't change transmit parameters remotely. The advanced operating complexity of a remote station requires an advanced level of knowledge for manipulating these transmitter controls, thus remote control stations are a privilege of an Advanced certificate holder.

### Remotes for Clubs: A Great Idea

Several clubs across Canada have set up remotes so club stations can be used by members who cannot have suitable antennas or equipment at their homes. By connecting over the web, members can take full advantage of a better-equipped station without the inconvenience of travelling to the club station.

But, what happens when a club member wants to use the remote, but does not hold an Advanced certificate? As a Basic certificate holder, you have not yet earned the privilege of operating a remote.

The club member has two options:

- Study and earn your Advanced: there are lots of options to prepare for the exam.
- Operate the station under the supervision of a "control operator" with an Advanced certificate.

With a control operator, you would be obliged to operate with the control operator's call sign or that of the club station. The control operator must be able to intervene immediately and take over the station in the event of a malfunction.

Setting up a remote for the use of your members is a great idea. It would be a mistake to underestimate the technical complexity of such a project. To do it

## "QUA: A Topical Digest" – continued from page 25

### Conclusions

As I researched this topic I realized that even a topic like reverse polarity protection that would seem to be relatively straightforward has many nuances that need to be considered in the design of equipment. If you would like to know more here are some references that I found helpful. I also recommend the DigiKey article mentioned previously.

- <https://pdfserv.maximintegrated.com/en/an/AN636.pdf>
- <https://sound-au.com/appnotes/an013.htm>
- <https://tinyurl.com/4nadb7n9>

### WSPR and its Coding

On a completely different topic, Kevin McQuiggin, VE7ZD/KN7Q, has an excellent article entitled "The 'What's It?' of WSPR" in the September-October 2023 issue of the SARC Communicator Journal, pages 15-24. If you want to know more about Weak Signal Propagation Reporter (WSPR) and its coding this article is a really good place to start. Along the way I am sure you will find other very interesting articles in this outstanding (and free) publication available at: <https://ve7sar.blogspot.com/>.

As always, if you have comments or questions contact me at [vy1kx@myrac.ca](mailto:vy1kx@myrac.ca).

responsibly requires clubs to limit the operation of the remote to those holding an Advanced qualification.

If your club has a remote and you have not yet earned your Advanced, start studying, pass that exam and earn that privilege. There are lots of courses and study materials available. Once you have passed the Advanced exam, you will have earned the privilege of setting up and operating remotely controlled stations amongst other "Advanced" privileges.

### Foreign Amateurs and Remotes

Clubs and individuals establishing remotes sometimes like to invite their foreign Amateur friends to use their stations. The requirement to hold a Canadian Advanced qualification stands. This is because *all* of our reciprocal operating agreements are for visitors to Canada.

To be a visitor to Canada, you must:

- Not be a Canadian Citizen or Permanent Resident; and
- Be physically present in Canada.

The Canada-US Treaty, the CEPT Licence and the International Amateur Radio Permit were all designed to facilitate operating by visitors from one country to another. Virtual visiting – ie, over the internet – is not visiting at all.

If you know of a Foreign Amateur who would like to operate a remote station in

Canada, based on the current RIC-3 they will have to pass our Basic and Advanced exams, then use their Canadian call sign. It's not impossible, it just requires a few extra steps.

### RAC Exam Standards Committee

The RAC Exam Standards Committee has worked through the entire Basic Question Bank. At time of writing in mid-November 2023, we are on track to deliver a complete package of recommendations for changes to the Basic exam.

Most of our recommendations focus on making the questions, the correct answers and even the incorrect answers clearer and a better test of knowledge. It will still be ISED's decision which of our recommendations to accept and when to implement a modified Question Bank. In my meetings with ISED, they have expressed a desire to ensure that trainers and authors of study materials have plenty of notice to modify their content.

### Modifications to RIC-1 still pending

ISED continues work to modify "RIC-1 – Guide for Examiners Accredited to Conduct Examinations for Amateur Radio Operator Certificates". One key issue is to formalize direction to Accredited Examiners on the conduct of online examinations. A revised RIC-1 should be released early in the new year.

– 73, Dave Goodwin, VE3KG



# World Radiocommunication Conference 2023

**Paul Coverdale, VE3ICV**  
**RAC Special Advisor**

The World Radiocommunication Conference 2023 (WRC-23) was held in Dubai, United Arab Emirates from November 20 to December 15 and brought governments together for negotiations on the allocation of radio-frequency spectrum.

There was good representation by Amateurs, with not only participation by the International Amateur Radio Union (IARU), but Amateurs participating on the national delegations of several countries, as does Canada.

In introductory remarks, the International Telecommunication Union (ITU) Secretary-General Doreen Bogdan-Martin, KD2JTX, specifically mentioned Amateur Radio:

“It’s the Amateur Radio operators who were able to send damage reports in the epicentre of an earthquake when all other communication channels were down”.

The structure of the Conference has been agreed and Chairs for Working and sub-Working Groups approved. Dale Hughes, VK1DSH is the Chair of the sub-working group dealing with Amateur Radio matters.

On the important topic of interference by Amateurs to the Radio Navigation Satellite Service (RNSS) in the 23 centimetre band, after much discussion over many months a new Recommendation M.2164 – “Guidance on technical and operational measures for the use of the frequency band 1240-1300 MHz by the Amateur and Amateur-satellite Service in order to protect the Radionavigation-Satellite Service (Space-to-Earth)” – had finally been agreed at the Radiocommunication Assembly which took place immediately before WRC-23.

At the beginning of the Conference there was still strong disagreement as to whether M.2164 should be interpreted as being mandatory or left as guidance for individual Administrations if they feel it is necessary.



**From left: Jon Siverling, WB3ERA, Paul Coverdale, VE3ICV, Barry Lewis, G4SJH, Flavio Archangelo, PY2ZX, Bernd Mischlewski, DF2ZC, Tim Ellam, VE6SH, Murray Niman, G6JYB, Ole Garpestad, LA2RR, Joel Harrison, W5ZN, Yudi Hasbi, YD1PRY, Peter Pokorny, VK2EMR, Dale Hughes, VK1DSH and Roland Turner, 9V1RT.**

By the end of the third week of WRC-23 in Dubai, after much discussion an agreement was reached.

There was initial strong disagreement as to whether Recommendation M.2164 “Guidance on technical and operational measures for the use of the frequency band 1240-1300 MHz by the Amateur and Amateur-Satellite Service in order to protect the Radionavigation-Satellite service (Space-to-Earth)” should be interpreted as being mandatory, or left as guidance for individual Administrations if they feel it is necessary.

The final outcome introduces a new footnote in the Radio Regulations regarding Amateur and Amateur Satellite Service operation in the 1240-1300 MHz range. This footnote recognizes that receipt of a report of harmful interference caused by a station of the Amateur or Amateur-Satellite Services, should be the trigger for Administrations to invoke the guidance in the most recent version of M.2164.

WRC-23 also agreed to suppress Resolution 774 “Studies on technical and operational measures to be applied in the frequency band 1 240-1 300 MHz to ensure the protection of the Radionavigation-Satellite service (Space-to-Earth)”, which closes the issue and satisfies the agenda item.

In the final week of WRC-23, an allocation was made for a spaceborne radar sounder operating in the 40-50 MHz range. There was some concern expressed about whether some signal would spill over into the lower portion of the 6m band, but geographical and operational limitations as well as allowable power flux density at the Earth’s surface make the likelihood of this happening very low in practice.

A footnote to the Radio Regulations for Region 2 identifies frequencies for International Mobile Telecommunications (IMT) in the band 10-10.5 GHz. This is only applicable to a number of central and south American countries and does not apply to Canada and the United States.

Agenda items have been determined for the next World Radiocommunication Conferences in 2027 and 2031. These include an opportunity for a possible new Amateur allocation in the frequency range 275-325 GHz; a definition of frequencies for Wireless Power Transmission (WPT) to avoid harmful interference to radiocommunications services (including Amateur); and initial studies which could lead to an Amateur allocation for communications on the lunar surface and between the lunar orbit and the lunar surface.

For more information please visit:  
<https://www.rac.ca/wrc/>

# “World Radiocommunication Conference revises the ITU Radio Regulations to support spectrum sharing and technological innovation”

## International Telecommunication Union Press Release Dubai, December 15, 2023

Member States of the International Telecommunication Union (ITU) agreed on revisions to the global treaty governing the use of the radio frequency spectrum, both on Earth and in space, at the close of the World Radiocommunication Conference 2023 (WRC-23) today in Dubai, United Arab Emirates.

The agreement on updates to the Radio Regulations identifies new spectrum resources to support technological innovation, deepen global connectivity, increase access to and equitable use of space-based radio resources, and enhance safety at sea, in the air, and on land.

“WRC-23 puts the world on a solid path towards a more connected, sustainable, equitable and inclusive digital future for all,” said Doreen Bogdan-Martin, ITU Secretary-General. “Key regulatory achievements on spectrum for space, science and terrestrial radio services build on the momentum of ITU’s ongoing work to achieve universal connectivity and sustainable digital transformation.”

A total of 151 Member States signed the WRC-23 Final Acts. The Final Acts constitute a record of the decisions taken at the conference including both the new and revised provisions of the Radio Regulations, all Appendices, and the new and revised Resolutions and ITU-R Recommendations incorporated by reference into the treaty by the conference.

“The agreements reached at WRC-23 are a testament to the unwavering spirit of cooperation and compromise among all of our members,” said Mario Maniewicz, Director of the ITU Radiocommunication Bureau. “Navigating the complexities of spectrum sharing to update the Radio Regulations has helped us forge a path that provides a stable, predictable regulatory environment essential for the development of innovative radiocommunication services for all.”

### Revisions to ITU’s Radio Regulations

Among the decisions, WRC-23 identified spectrum for International Mobile Telecommunications (IMT), which will be crucial for expanding broadband connectivity and developing IMT mobile services, also known as 4G, 5G and, in the future, 6G. That new spectrum includes the 3 300-3 400 megahertz (MHz), 3 600-3 800 MHz, 4 800-4 990 MHz and 6 425-7 125 MHz frequency bands in various countries and regions.

WRC-23 also identified the 2 GHz and 2.6 GHz bands for using high-altitude platform stations as IMT base stations (HIBS) and established regulations for their operations. This technology offers a new platform to provide mobile broadband with minimal infrastructure using the same frequencies and devices as IMT mobile networks. HIBS can contribute to bridging the digital divide in remote and rural areas and maintain connectivity during disasters.



**Doreen Bogdan-Martin, Secretary-General of the International Telecommunication Union, at WRC-23 in Dubai.**

For non-geostationary fixed-satellite service Earth Stations in Motion (ESIMs), the conference identified new frequencies to deliver high-speed broadband onboard aircraft, vessels, trains, and vehicles. These satellite services are also critical following disasters where local communication infrastructure is damaged or destroyed.

Provisions were included to protect ship and aircraft mobile service stations located in international airspace and waters from other stations within national territories.

To support the modernization of the Global Maritime Distress and Safety System (GMDSS), WRC-23 took regulatory actions including the implementation of e-navigation systems to enhance distress and safety communications at sea.

The conference provisionally recognized the BeiDou Satellite Messaging Service System for GMDSS use, subject to successful completion of coordination with the existing networks and elimination of interference.

The WRC-23 negotiations were led by conference Chair, H.E. Eng. Mohammed Al Ramsi from the United Arab Emirates with assistance from six committee chairs: Basebi Mosinyi (Botswana); Cindy Cook (Canada); Hiroyuki Atarashi (Japan); Anna Marklund (Sweden); Abdouramane El Hadjar (Cameroon); and Christian Rissone (France).

Overall, WRC-23 approved 43 new resolutions, revised 56 existing ones, and suppressed 33 resolutions. Other key WRC-23 outcomes include:

- 1) Allocation of additional frequencies for passive Earth exploration satellite services to enable advanced ice cloud measurements for better weather forecasting and climate monitoring.

2) Allocation of new frequencies to the aviation industry for aeronautical mobile satellite services (117.975-137 MHz). The new service will enhance bi-directional communication via non-GSO satellite systems for pilots and air traffic controllers everywhere, especially over oceanic and remote areas.

3) Allocation of the bands 15.41-15.7 GHz and 22-22.2 GHz in Radio Regulations Region 1 and some Region 3 countries to the aeronautical mobile service for non-safety aeronautical applications. This will enable aircraft, helicopters, and drones to carry sophisticated aeronautical digital equipment for purposes such as surveillance, monitoring, mapping, and filming, and have the capacity to transfer large data from these applications using wideband radio links.

4) Adoption of regulatory actions for the provision of inter-satellite links. This will allow data to be made available in near-real time, enhancing the availability and value of instrument data for low-latency applications such as weather forecasting and disaster risk reduction.

5) Endorsement of the decision by the International Bureau of Weights and Measures (BIPM) to adopt Coordinated Universal Time (UTC) as the de facto time standard by 2035, with the possibility to extend the deadline to 2040 in cases where existing equipment cannot be replaced earlier.

6) Recognition of the importance of space weather observation in a new Resolution and a new Article in the Radio Regulations to recognize the operation of space weather sensors as part of the meteorological aid service to observe space weather phenomena including solar flares, solar radiation and geomagnetic storms which can interfere with radiocommunication services including satellites, mobile phone services and navigation systems.

7) Approval of a recommendation by the Radio Regulations Board to allow 41 countries to acquire new and usable orbital resources for satellite broadcasting. The countries were unable to use their assigned orbital slots in recent years due to factors such as lack of coordination and interference from other satellite networks. The decision aims to enable countries to implement subregional satellite systems.

To prepare for future world radiocommunication conferences, the WRC-23 also adopted several resolutions that mandate the ITU Radiocommunication Sector Study Groups to undertake studies on specified topics that include:

1) Possible new or modified space research service (space-to-space) allocations for future development of communications on the lunar surface, and between lunar orbit and the lunar surface.

2) The development of regulatory measures to limit the unauthorized operations of non-geostationary-satellite orbit (non-GSO) earth stations in the fixed-satellite service (FSS) and mobile-satellite service (MSS).

3) Technical and regulatory measures for fixed satellite systems (FSS) while taking into account the specific needs of developing countries including the need for equitable access to the relevant frequency bands.

**Radioworld.ca**  
Canada's favourite Amateur Radio Stores!

**We wish to say...**



**We appreciate your support and patronage!**  
**Serving Canadians for over 25 years.**

**Radioworld** central **Radioworld**  
Toronto, ON      Calgary, AB  
866-666-8600      800-585-9331

4) Technical and regulatory provisions necessary to protect radio astronomy operating in specific Radio Quiet Zones from radio-frequency interference caused by systems in the non-geostationary-satellite orbit.

5) Possible new allocations to the mobile-satellite service for direct connectivity between space stations and mobile user equipment to complement terrestrial mobile network coverage.

6) Spectrum needs and appropriate protection criteria for space weather sensors.

7) Potential new frequency allocations and regulatory actions for future development of low-data-rate non-geostationary mobile-satellite systems (small satellites).

8) Identification of measures to facilitate the operation of earth stations on board unmanned aircraft, including identification of suitable frequency bands to decide on the appropriate course of action to be taken in 2031 (WRC-31).

WRC-23 also approved the agenda items for the next World Radiocommunication Conference (WRC-27) and the provisional agenda for WRC-31.

Over 3,900 delegates from 163 Member States attended WRC-23, including 88 ministerial-level participants. Women made up 22 per cent of all WRC-23 delegates, an increase from 18 per cent at WRC-19 in 2019.

Source: WRC-23 Newsroom:  
<https://www.itu.int/wrc-23/newsroom/wrc-news/>



# RAC OFFERS BOTH BASIC QUALIFICATION STUDY GUIDES

## The Hamstudy Basic Study Guide 2021/2022



Hamstudy Basic 2021/2022 is the 4th edition of a Study Guide that is published by Radio Amateurs of Canada. The content mirrors the subscription-based self-study course offered at <http://www.hamstudy.com>.

This is the perfect reference for new Radio Amateur enthusiasts. It provides everything needed to qualify for the Basic Exam.

- ✓ Innovation, Science and Economic Development's complete examination Question Bank
- ✓ Based on the popular Internet self-study course Hamstudy
- ✓ Low price of \$41.54 (plus shipping and taxes)

### Key information:

- ✓ Basic qualification is required to obtain your call sign
- ✓ Exams are multiple choice – 70% to pass
- ✓ 80% or higher marks gives you access to the HF bands

For more information visit <http://www.hamstudy.com/>

**HAMSTUDY** BASIC

**2021/2022**

EVERYTHING YOU NEED TO KNOW FOR YOUR CANADIAN BASIC EXAM

RADIO AMATEURS OF CANADA  
www.rac.ca

## The Canadian Amateur Radio Basic Qualification Study Guide, 9th Edition – 5th Printing

This Study Guide includes all information required to pass the current Innovation, Science and Economic Development's examination. Please see the ad on page 19 for information on the new 5th printing.

Coax Publications Study Guides are revised bi-annually or whenever changes occur in the Question Bank.

- ✓ Matched to the Question Bank update in 2020 with more context for the new and revised questions
- ✓ Still includes unlimited time access to the acclaimed online Student Success Pages support
- ✓ Our *Ask The Professor* help is added for some questions
- ✓ Current stock: \$49.95 plus shipping and taxes

For more information visit <https://www.rac.ca/study-guides-2/>

Canadian Amateur Radio Basic Qualification Study Guide

CA  
VOLTS  
AMPS  
NO CONTACTS  
NC CONTACTS

Ninth Edition

Includes Unlimited Access To Student Success Pages On Our Web Site!

Coax Publications Inc

For more information about getting started in Amateur Radio visit: <https://www.rac.ca/how-to-begin/>

# A “Light-Touch” Push-to-Talk Switch for Boom Mic Desktop Operation

**Don Dorward, VA3DDN**

I recently installed a boom microphone for use with my new Yaesu FTDX10 HF transceiver, with a Heil HM-12 microphone. Not having looked ahead too far, I soon discovered that first I needed a suitable mic-to-radio cable with pin-out for the DX10, and I also would have to have either a foot switch or some other kind of hand switch to operate the PTT – egads! Yet more \$\$.

Well I immediately ruled out a foot switch, which I considered as being big and “clunky”, with yet another cable to get tangled up in. Not to mention the horror stories from other Amateurs about desperate “foot-groping” for the foot switch beneath the operating position at critical times.

A hand switch was a possibility and several options were out there such as a “modified” hospital call switch with a button on the end, or a “trigger” type handheld switch such as offered by Heil.

I have severe arthritis in my hands (as well as in other places!) and neither of these options would work for me – prolonged times of clenching my hand would be a problem. I realized that what I needed and wanted was a basic low-force, push-on, push-off switch that could live obscurely on my desk near to the transceiver.

Figure 1 shows some of the switches that I acquired for testing, after scouring online catalogues etc. In the end I chose just two for further testing:

- the Leviton 1451 “quiet” AC toggle switch (<https://www.leviton.com>)
- the NKK YB16xxx push-button, that had many options for buttons, colours etc (<https://www.nkkswitches.com/>)

With either one, there were potential mounting issues. The NKK switch, although quite short, still needed its solder terminals bent almost 90 degrees in order to fit in the one-inch high Hammond 1590G aluminum box I favoured (<https://www.hammmfg.com>).



Figure 1: A few of the switches.



Figure 2: The completed PTT switch.

However the AC toggle switch would need more extensive Metal work to adapt the toggle handle to the aforementioned aluminum box – actually I still like it a lot!

Figure 2 shows the completed PTT switch in use using the NKK switch in the Hammond box, painted fire engine red! Note: for a few more dollars you can get a Hammond pre-painted box which likely looks better than my home-painted version!

The simple schematic is shown in Figure 3 on the next page with the parts needed.

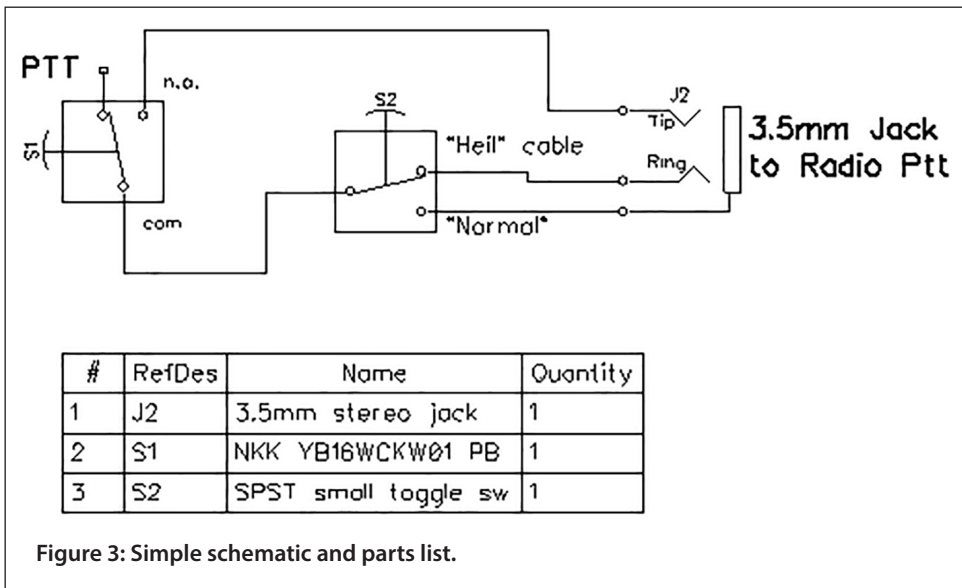

Figure 3: Simple schematic and parts list.

**Notes:**

- 1) The bottom of the Hammond box was lined with insulation paper, which we used to call "fish-paper" back "in the day" for some odd reason. This is to prevent shorting, in case the switch terminals get too close.
- 2) Normal PTT connections are from the chassis ground to the designated PTT pin in the microphone connector. Hence connections in the box to the 3.5 millimetre jack are from the ground terminal to "tip" connection. However, if you use a Heil connection – as in the Heil pigtail PTT jack – then PTT ground is the "ring" connection on the 3.5 millimetre jack. Switch S2 allows choosing which connection method you use.
- 3) The NKK switch button can be illuminated by an internal LED to show when it's "ON". There are issues such as where to get 3 VDC or more for the LED, sharing the PTT switch with LED current etc., so I decided not to do that at this time. It should be pretty obvious when the rig is transmitting without illuminating the button.

Don Dorward, VA3DDN, has had 43+ years experience in the electronics industry including vacuum tube manufacturing, semiconductor and component testing, R&D, ISO Quality Systems, Regulatory Affairs, UL/CSA/EU/CE/EMC compliance, Environmental testing, Standards & Calibration. He has been an Amateur Radio operator since 2002. He is a Life Member of the Institute of Electrical and Electronics Engineers (IEEE) and is a member of the American Radio Relay League (ARRL), Radio Amateurs of Canada (RAC) and the Radio Society of Great Britain (RSGB). He can be reached at va3ddn@myrac.ca.



**Amateur Radio Operators of Canada**

Share your OTA adventures, DIY Builds, or maybe learn CW. The discord chat is a great place to find hams near and far to discuss a range of topics 24/7.

Come check us out at the link below.

73s

Discord.me/AmateurRadioCanada

**SPECIAL DEAL FOR RAC MEMBERS**

**10% OFF BOOKS**  
at the **RSGB Bookshop**

Simply insert the following code:  
**RACdiscount**  
(Excludes Postage)

**Get great books delivered to your door, and benefit the RAC in the process**

Radio Society of Great Britain [www.rsgbshop.org](http://www.rsgbshop.org)  
3 Abbey Court, Priory Business Park, Bedford, MK44 3WH. Tel: 01234 832 700 Fax: 01234 831 496

# WORLD AMATEUR RADIO DAY AWARD

PROMOTING GLOBAL FRIENDSHIP AMONG AMATEURS WORLDWIDE



## World Amateur Radio Day Thursday, April 18

<https://www.rac.ca/world-amateur-radio-day/>

Every year on April 18, Radio Amateurs worldwide take to the airwaves in celebration of Amateur Radio and to commemorate the formation of the International Amateur Radio Union (IARU) on April 18, 1925.

Radio Amateurs of Canada is once again holding a "Get on the Air on World Amateur Radio Day" special event in which we encourage as many Amateurs as possible to get on the air and contact as many RAC stations as possible.

<https://www.rac.ca/world-amateur-radio-day/>

# “My Siberian DXpedition”

Raisa Skrynnikova, R1BIG/OH7BG/VO1BIG

I live in St. Petersburg, on the shores of the Baltic Sea, almost in the very west of Russia, and travelling to the Urals and Siberia has long been one of my dreams.



But this only came true thanks to Amateur Radio when I made friends in all the cities through which the route would pass.

Of course, I planned to go on air and activate various interesting places in the east, but I couldn't take the equipment with me as it's heavy and in any case is prohibited on airplanes. Therefore, from this point of view, it was important to have local support for transport, equipment and antennas.

My radio journey to Siberia began in the Urals at Yekaterinburg, right on the border of Europe and Asia. There is a special sign installed there, symbolizing this line between the continents (see top photo).

I was QRV (169 QSOs), practically in a special “DX position” with one foot in Europe and the other in Asia. (Figure 1)

The next day I participated in the Russian Radio Fox Hunting (ARDF) Championship in the 3.5 MHz band as shown in the photo on the right.



I catch “foxes” at an amateur level and don't compete with the cool athletes.

I like to move through the forest with a direction finder, listen to foxes on the air and try to correctly reveal their location. This is also radiosport – a very active version.

Yekaterinburg is a very beautiful city. You understand this best when you are at an altitude of 188 metres on a local skyscraper (Figure 2).

Thus ended the first two days of my trip to the Urals. The next day I visited the Institute of Firefighters and Rescuers, where the young collective station RA8CP is located (Figure 3). I answered questions from students about my journey on Amateur Radio and also worked on air – this time with the noise of a large city with a million population, the largest city in the Urals.



Figure 1: One foot in Europe and the other in Asia.



Figure 2: Enjoying the view of Yekaterinburg.



Figure 3: Answering questions from students at RA8CP station.

Next, my path lay east to my cherished dream – Lake Baikal. From my hometown of St. Petersburg it is almost 6,000 kilometres to Lake Baikal. But I was already almost halfway and had 3,500 kilometres to fly over Siberia to the city of Irkutsk.

In Irkutsk, which is located on the Angara River near Lake Baikal, I was again warmly received by local Radio Amateurs and provided great assistance in organizing my further travel and activating this place on the air. After all, it is completely impossible to fly with your own equipment.

First, I visited the local Museum of Communications (Figure 4). I then went to the main goal of my trip: the world's deepest lake – Lake Baikal – containing 23% of the world's fresh water resources.

The hike along the shores (Figures 5 and 6) of this grandiose lake and the activation on air (see below) left an indelible impression.

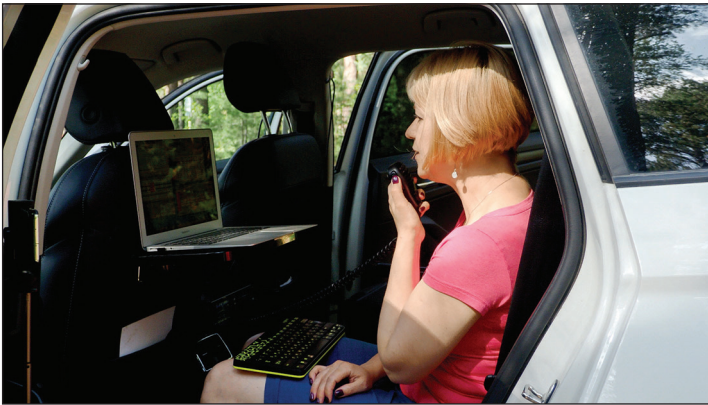

I was once again convinced that our hobby is not just sitting in “The Shack”, as many people imagine it to be. This includes: making and meeting new friends around the world; travelling with the activation of interesting points; and the excitement of learning new things, both in technology and in life in general.

On my online resources – YouTube, Facebook and Instagram – and offline, whenever possible, I try to explain this to as many people as possible who are interested in decorating their lives with new experiences.

– 73, 88, Raisa, R1BIG/OH7BG/VO1BIG (<https://Raisa.blog/>)

*Raisa Skrynnikova (41), was born in Tashkent, Uzbekistan. Since 2005 she has lived in St. Petersburg and was first licensed there as a Radio Amateur in 2018. Since then, life has been inextricably linked with Raisa's desire to promote Amateur Radio on social networks and YouTube, including and “especially among young people and ladies”.*

*Raisa participates in all major contests, makes pileups, works in the field, goes on DXpeditions, and arranges Amateur Radio events and meetings. At the moment, Raisa's subscribers in her main accounts total about 30,000 people, some of whom admit that they received their certification after watching her path to Amateur Radio.*

*In 2020, Raisa received the Finnish call sign OH7BG (since she often worked from Finland), and in 2021, a Canadian call sign VO1BIG, which she uses for remote QRV via Rob Noakes, VE3PCP. The main call sign is still R1BIG and it is easy to find all Raisa's activities online using it as a search word.*



Figure 4: A visit to the Museum of Communications in Irkutsk.



Figure 5: Hiking at Lake Baikal. |



Figure 6: A beautiful view!

TCA 



*Degen*

Antennas, Connectors, Cables and More

WWW.DEGENDESIGNS.COM

416-347-8517

SALES@DEGENDESIGNS.COM



### Gold / Or

Tim Ellam, VE6SH

### Silver / Argent

Francois Daigneault, VE2AAY  
Craig Delmage, VE3OP  
Eric Kehler, VA7NX  
Ronald Vadeboncoeur, VE3REV  
Gerard White, VO1OR

### Bronze / Bronze

Dave Ackerman, VE3UGT  
Yvonne Adam, VE3RYA  
Michael Adams, VE2KVU  
Rob Adams, VE6YXE  
Russell Adams, VE7MTU  
John Alexandersen, VE5JJA  
Stuart Allan, VE3STY  
Paul Allen, VA3PB  
Chris Allingham, VE3FU  
Christopher Allsop, VE3SKH  
Pablo Alvarez, VE3FNT  
Wayne Anderson, VE3UWA  
Michael Anson-Cartwright, VA3QAC  
Luis Araiza Chavez, VA7WCR  
David Argo, VE3NLZ  
Les Arnott, VE3UCW  
Ken Asprey, VE1PDL  
Gijo Augustin, VE2GIJ  
Cory Austen  
Gary Badcock, VO1GWC  
Tim Bailey, VE3TXB  
Bernard Baker, VA3BGB  
Doug Bannard, VE3SPF  
Lance Barber, VE4JLB  
Douglas Barnes,  
David Barnes, VO1YA  
Lawrence Barnett, VE6WL  
Kelly Barr, VA2KRB  
Eric Barr, VA7EHB  
Wayne Barrey, VE3JV  
David Barron, VE3ZKA  
Trevor Batstone, VE7BM  
Matthew Batten, VE3ZQW  
Geoffrey Bawden, VE4AE  
William Bayrak, VE7WAJ  
Gary Bazdell, VA3GBZ  
Don Bedard, VA6BED  
Warren Bekker, VA3WEB  
Michael Bell, VE3NOO  
Cary Benson, VA7MXY  
David Bernard, VE3YH

# RAC MEMBERSHIP / ADHÉSION À RAC

## RAC MAPLE LEAF OPERATOR MEMBERSHIP / ADHÉSION À "OPÉRATEURS MAPLE LEAF" DE RAC

Michel Bickerstaffe, VE3AQE

Adam Bird, VA3IRD

Chris Bisailion, VE3CBK

Leif Bjornson, VE7LTB

Stewart Blackburn, VE7SZB

Clinton Blackmore, VE6CWB

Henry Blais, VE3HJL

James Blemkie, VA3JXB

Colin Bodor, VA6CCB

Roy Boehli, VE6CBG

Denis Bois, VE3OOZ

Sidney Boloten, VE7BIA

Don Booker, VA2EEK

Ashraf Botros, VE3ANO

Bruno Bouliane, VE2VK

Rodrick Bourque, VE9HV

Jeremy Bourque, VE9RJB

Matthew Bovolotto, VE3QMB

Jason Bowolin, VE7JBQ

Allan Boyd, VE3AJB

Robert Boyer, VE3XBB

Steven Bradshaw, VE7CBH

Patrick Brewer, VE3KJQ

Michael Brickell, VE3TKI

L.A. Robert Brosseau, VA2DBJ

Yvan Brosseau, VE2DYY

Eric Brown, VA6EBR

Matthew Eric Brown, VE3EB

Edward Brown, VO2ED

Ian Brownlee, VA4IAM

James Bruce, VE4ATL

Denis Brunette, VA3DCB

Karen Bryden, VA3IGO

Eric Bryer, VE3HF

Nino Bucciarelli, VE1NDB

Don Buchan, VE3DBM

Harry Buckley, VE3YSH

Pam Buckway, VY1PJB

Richard Budny, VA3RSA

Guy Bujold, VE2CXA

Ron Bull, VE7DIO

William Burgess, VE3CRU

Paul Burggraaf, VE3PRB

Rob Burns, VA3KGY

Gary Butler, VE7OQ

Simon Butt, VA7ZAW

Dale Butt, VE3IOU

Paul Caccamo, VA3PC

David Caddell, VA7VVV

Frederick Cain, VE3JMJ

Michael Caissie, VE9MCA

Bruce Calhoun, VE3BER

Antonio Callà, VE7AXI

Ralph Cameron, VE3BBM

Jordan Campbell

Jim Campbell, VE1DXL

Mark Capewell, VA7MNV

Mary Card, VE3FEB

Ben Carter, VA7FK

Malcolm Challis, VA7MKB

Chris Chant, VE3CDC

Borden Chapman, VA1CBC

Rob Chartier, VA7QAD

Gilles Chevalier, VA2CG

John Chin, VA3BOF

Janice Lynn Clanfield, VA3POX

Ernest Clintberg, VE6ECK

Scott Clitheroe, VE3QBZ

Yael Cohen, VE7YDC

Reginald Collie, VE1DOG

Bob Conlon, VE6UKR

Karen Conner

Aaron Conner, VA6ATC

John Connor, VE3TG

Johnny Console, VA3MOF

Daryl Corbett, VA3UAP

Brendan Cormier, VE1BTC

Pierre Cossette

Guy Costanzo, VA7GAC

Justin Cotreau, VE1JJC

David Coutts, VA7UX

Robert Cove, VO1REC

Mary Coyle, VE3MVM

Paul Cragg, VE3AXT

Andrew Csinger, VE7UM

Vanja Culjak, VA3XLJ

Mark Cundict, VA6MKC

Terry Cutler, VE5TLC

Jeff Dale, VA3ISP

Rick Danby, VE3BK

Brian Davies, VE6CKC

Glenn Davis, VE3WGD

Frank Davis, VO1HP

Paul de Bourcier, VE7ELD

Karel De Vries, VE7KDV

John DeBoer, VE3XXJ

Andrew DeMarsh, VE3HCA

Luc Desnoyers, VE2AEI

Richard Dion, VE3LAD

Grant Dixon, VE3CGV

Lawrence Dobranski, VA3IQ

William Dorfmann, VE7WDO

Richard Dow, VE3DQW

Michael Doyle, VE3EJF

Nicholas Doyle, VE7NCD

Keith Drader, VE6KKD

Mike Drake, VA3BKQ

George Duffield, VE3WKJ

Lachlan Dufton, VE7ZUM

Denis Duquet, VA3MAD

Peter Dwan, VE6DWN

Matthew Dwight, VE3OCC

Robert Dyer, VE3KTY

Michel Dyotte, VA2MDY

Robert Eichhorn, VA7RPE

Clinton Elliott, VA6CBE

Jeffrey Ellis, KD9BLO

Mark Ellison, VA2MKE

Brett Emerson, VE3SJA

David Empey, VE3KVR

Leif Erickson, VA7CAE

Paul Albert (Al) Eros, VE4ZB

Marcel Eschenmoser, VE3UKW

Albert Everett, KF5LNM

Gordon Fairchild, VE3GDN

Antony Fenton

Richard Ferch, VE3KI

Margaret Ferguson, VA7VF

Andriy Fesun

Halden Field, VE7UTS

Garrick Filewod, VE3ONU

Terry Finn, VE6TF

Sally Finora, VA7SMF

Bob Foley, VE3RVZ

Scott Fortnum, VE3ISF

L Clare Fowler, VE3NPC

Doug Frame, VE3JDF

Ed Frazer, VE7EF

Norm Freidin, VE3CZI

Stefan Fridriksson, VA3FDX

Rob Fry, VA3FR

G Keith Fuller, VE7GKF

Frank Fullum, VE2KOI

David Gallois, VA3DGA

Frank Garofalo, VA3FGF

Jean Gauthier, VA2NJG

David Gervais, VE6KD

Brett Gibson, VA3EES

Phil Gibson, VA3KDC

Paul Giffin, VE7IPM

John Gilje, VE6KJG

Keith Gill, VE3KRU

William Gillies, VO1WJG

Eric Gingras, VA3DZY

Vince Giroux, VA3WGI

Alexandre Giroux, VE3OYO

Thomas W. Godden, VE3TWG

Carlos Ernesto Gomes Medeiros,  
VA3VIE

Dave Goodwin, VE3KG

Stephen Goodwin, VE6SMG

Donald Gover, VA6DLG

Timothy Graham, VE7LXC

William John Grandell, VA3WJX

David Green, VE3TLY



Dustin Greig, VE6SVN  
 Guy Grosjean, VA3ZHF  
 Michael Grover, VE7MGQ  
 Colin Guillas, VA3CSG  
 J. Paul Guy, VE8JG  
 Tom Haavisto, VE3CX  
 Will Haggerty, VA1HEL  
 Bruno Haineault, VE2EQ  
 Alan Haines, VE3ALH  
 Lana Hale, VA6LDH  
 Don Hamilton, VA7GL  
 David Hamilton, VE6DWH  
 Gordon Hamilton, VE7ON  
 Garry V. Hammond, VE3XN  
 Jovan Hamovic, VA7JOV  
 Richard Hanishewski, VE5RH  
 Henry Hansen, VE6HNN  
 Douglas Hardy, VE7HZY  
 Brad Harris, VE3MXJ  
 Gerald Harris, VE6GBH  
 Bertram Harrison  
 Yvan Harvey, VE7DVY  
 James Haworth, VE3DXG  
 Harm Hazeu, VE4HAZ  
 John Hemingway, VE3HAY  
 Jean-Paul Henault, VE2JHP  
 Hugh Henderson, VY1HH  
 Mathew Hengst, VE9GF  
 Paul Henry, VE3CPH  
 Jody Herperger, VE5SAR  
 Randy Hewitt, VA3XFE  
 James W. Hodgson, VE3HOV  
 Peter Hodgson, VE3UR  
 Frank-Michael Hofmann, VE6FMH  
 Csaba Hollo, VA7NDT  
 Roger Hopson, VA3HPR  
 Gabor Horvath, VE7DXG  
 Alan Hotte, VA3IAH  
 Robert (Bob) Howard, VE3YX  
 Derek Howes, VE3BRV  
 Adrian Huber, VA7AGH  
 Jim Humphrey, VE3TKV  
 Mark Humphreys, VA5LNX  
 Harold Hunt, VA3HWE  
 John Hunter, VA3OOD  
 Jan Hykamp, VA3EPP  
 John Illes, VE7JSI  
 James Irvine, VE3UZX  
 Lorne Jackson, VE3CXT  
 Gordon John Jacques, VA3GJJ  
 Peter Jago, VA3PJ  
 Zain Jaison, VA7VZN  
 Stephen Jamieson, VA3ZXN

Robert Jankov, VA3KRJ  
 S. Wray Jaques, VA3EO  
 B.M. Jatzcek, VA6BMJ  
 Jason Johnson, VE3PEJ  
 Dave Johnson, VE7VR  
 Harris Jones, VA3HMJ  
 Jeremy Jones, VA3ZTF  
 James Joyce, VE3LTN  
 Jean-Michel Julien, VE2ZEB  
 Ernie Jury, VE3EJJ  
 David Kammann, VA3DKM  
 Gordon Kelland, VO1KGZ  
 Jason Kendall, VE3YCA  
 Stephen A. Keppel, VA3LDK  
 Ryan Kerr, VA6FTW  
 Richard Kettle, VE3QRK  
 Patrick Kierans, VE3KPA  
 R Neil King, VA7DX  
 David Kingsland, VE3MDX  
 Glen Kinner, VE5GHK  
 Erland Kirste, VE7EFK  
 David Klatt, VE5GN  
 Peter Knazko, VE3ZKZ  
 Boris Kohut, VE4BG  
 Brian Konopski, VE4KON  
 Larry Konowalchuk, VA4LMK  
 Gordon Kosmenko, VE6SV  
 Mahendra Kumar, VR2ER  
 Steven La Hay, VE6SCL  
 Luc LaCasse, VE2LLX  
 Leslie Laffoley, VE9ASN  
 David LaHay, VE7FVW  
 Ken Laker, VE3LRK  
 Robert Laramée, VE2KZW  
 Don Latter, VE7DIL  
 Derrick Lau, VA3LGT  
 Al Law, VE3FZ  
 Samuel Leach, VO1CBL  
 Gregory Leck, VA2LCK  
 Francis Leclerc, VE2FLP  
 John Lediett, VE3FVC  
 Gerald Lehtola  
 Guy Lemieux, VE2BWL  
 Barrie Lennox, VE3AOI  
 Stan Leschinsky, VE3TWW  
 Ritchie Leslie, VA7RLX  
 Joel Levis, VE3CJJ  
 Peter Liatowitsch, VE7PLI  
 Trevor Lien, VE5TDL  
 Carolyn Liggins, VE1CRL  
 David P. Lopetinsky, VE6ELL  
 John Lorenc, VA3WM  
 Daren Lorentz, VA6DRL

Greg Loucks, VE9PHX  
 Gordon Lowick, VE7YMF  
 James Ludwar, VE6JWL  
 Eric Lusk, VE7EMI  
 Ancil Lynch, VA3FIP  
 Paul Lynott, VA3PNL  
 Jory Maccan, VE6JBM  
 Richard MacDonald, VA1UAV  
 Charles MacDonald, VA3CPY  
 Glenn MacDonell, VE3XRA  
 Ian MacFarquhar, VE9IM  
 Mike MacGregor, VE3QMM  
 Darcey MacInnes, VA7DKY  
 John MacKay, VE7EEX  
 Robert MacKenzie, VA3RKM  
 Neil Macklem, VE3SST  
 Terrance MacLean, VE9ATM  
 Frank Maddix, VA3FMM  
 Pierre Mainville, VA3PM  
 Alan Mallett, VA7AWM  
 Eric Manning, VA7DZ  
 Rick Marcogliese, VE3RVV  
 Bruce Marshall, VA6BRM  
 Gregory Mason, VE4AMN  
 Marc Masson, VE2MMH  
 Gabriel Mazzeo, VA3CWT  
 Phil McBride, VA3QR  
 Don McCallan, VA3GFD  
 Hugh McCully, VE3AYR  
 Brian McDonnell, VA3CBG  
 Leonard McDougall, VA5MCD  
 Doug McDougall, VE3DGY  
 Steve McEdwards, VA3TPS  
 William McEvoy, VE3NEF  
 John McGrath, VE3JPW  
 Ken McIntosh, VA7KBM  
 Andrew Allan McKay, VA4XRY  
 L. David McLennon, VO1LM  
 Grant Mcsorley, VY2GAM  
 Martin Menard, VA3EIC  
 Robert Millar, VE3LNV  
 Ken Miller, VE3KQR  
 Roger Miller, VE3ROG  
 Eric Mills, VE1AST  
 Michael Milosevic, VE3EQM  
 Vladimir Milutinovic, VE3JM  
 Andrew Mitchell, VA3CW  
 J.T. Mitchell, VE6OH  
 Paresh Mody, VE3PQX  
 Lenard Moen, VA3HBR  
 Jean Moffett, VE3WAD  
 Marcel Mongeon, VA3DDD  
 John Moylan, VA3YOM

Harry Mueller, W1HMM  
 Wilf Mulder, VE7OHM  
 Eric Mundle, VA3EAM  
 Gordon Murray, VE3JSJ  
 Bruce Murray, VE6BRZ  
 Mykhailo Mykhno, VE7WOA  
 Robert Nash, VE3KZ  
 Jim Nelson, VE6ACR  
 Chris Nielsen, VA6JCN  
 David Niemi, VA3NIE  
 Allan Niittymaa, VA3KAI  
 Brian Nilsson, VE3SLB  
 TREVOR NISBET, VA7TLN  
 Andrew Norwood, VE3YTP  
 Mark Nowicki, VE3MNA  
 Brad O'Brien  
 Keith Olson, VE4VO  
 Alex Opotchanov, VE6ALO  
 Jeff Page, VA3OBJ  
 Ed Pasetka, VE5AM  
 Gordon Passmore, VA7GAP  
 Bruce Patten, VE7PTN  
 Bruce Patterson, VE7XBP  
 Tony Pattinson, VE2KM  
 Colin Pavey, VA3FP  
 Irmgard (Geddie) Pawlowski  
 Bruce Payan, VE7CGN  
 Tim Pekkonen, VE3UO  
 Steve Pengelly, VE3STV  
 Raymond Perrin, VE3FN  
 Lars James Taillon Petersen  
 Brent Robert Petersen, VE9EX  
 John Peterson  
 Jim Pierce, VA1YZX  
 Richard Pierik, VE1RPX  
 Dale Pilsworth, VA6OK  
 Bruce Poirier  
 Marc Poitras, VE3VEB  
 Gary Pollock, VE1GMP  
 Gregory Popelas, VA3CBN  
 Peter Potjewyd, VE3WYD  
 Terry Potts, VE3TEP  
 John Potts, VE6JWP  
 Scott Prior, VA7LMP  
 Theodore Arthur Rachwal, VE9AQM  
 Victor Rowell Radovan, VE4RWL  
 Kolya Ramirez-Hughes, VE5KE  
 Paulo Ranzani, VE8PR  
 Norm Rashleigh, VE3LC  
 Tony Ratcliffe, VE6AER  
 Glenn Rattray, VA6AGR  
 Bryan Rawlings, VE3QN

William Redmond, VA3WBR  
 Steve Regan, VA3MGY  
 David Reid, VE6BIR  
 Robert Rennie, VA3BSJ  
 Gilles Renucci, VE2TZT  
 Guy Richard, VE2XTD  
 Earl Richardet, VE7QJ  
 Randall Risto, VE6RND  
 Simon Rizzardo, VE7RIZ  
 Jeff Robb, VE3MDC  
 Donald Robinson,  
 William Robinson, VE3ARE  
 J. Mark Robinson, VE3JMR  
 Allan Ross, VE7WJ  
 Shaun Rossi, VE3FNI  
 Louise-Michelle Rouillard,  
 Don Rowed, VE3KII  
 Dave Rowlinson, VE3ZDR  
 Cary Rubinfeld, VE4EA  
 Robert (Bob) Ryll, VA7RYL  
 Ted Rypma, VE3TRQ  
 Bunty Saini, VA3KBM  
 Mason Salmon, VE7PMD  
 Edward Samborski, VE3TAS  
 Dan Sanchez, VE7EOZ  
 David Sangwin, VA3NSC  
 Kim Schaffer, VA3ZXC  
 Bill Scholey, VE7QC  
 Trevor Schriver, VE3VVB  
 Mark Scola, VA3HES  
 John Scott, VE1JS  
 Joseph Scott, VE3ADB  
 David Scott, VE3ZZU  
 Don Scott, VE7DLI  
 Ian Seddon, VE3HUT  
 Zachary Seguin, VA3ZTS  
 David Serednicki, VE3XSU  
 Gord Settle, VY1GS  
 Ian Shaw, VE3IJS  
 Harold Shepherd, VE3HSB  
 Ronni Shino  
 Pietra Shirley, VE4PXL  
 Joseph Shynn, VA3GOC  
 Boris Sidelnikov, VE3DQ  
 Kevin Sidlar, VA3SID  
 André Silveira Santos de Souza,  
 VA2HAS  
 Antonio Simonetta, VE3WZM  
 Glenn Simpson, VE3GTS  
 Jack Sinclair, VA3WPJ  
 Ron Sinclair, VE3JRN  
 Erik Skovgaard, VE7MDL  
 Curtis Smecher, VE7CAS  
 Douglas Smith, VE3OUI  
 Richard Songhurst, VE7XU  
 Patrick Speer, VE7PJS  
 Ron Spencer, VA3RSX  
 Mark Spencer, VE7AFZ  
 Tom Spina, VE7TKS

## New Members: October to November | Nouveaux membres : octobre à novembre

Sameh Altakla, VA7SYA  
 Keith Baribeau, VA2KB  
 Douglas Barnes  
 Leonard Bland, VE7LBP  
 Chris Brandson, VA7RXD  
 Joshua Caissie, VA3ZJC  
 Joe Campbell  
 James Cann, VE3MEK  
 Zhen Cao, VA2AFX  
 Vijay Chander, VDAY  
 Eduardo Cristo, VA7ECR  
 Michael Cutts, VA3UTT  
 Jean-Claude Daehler, VE7AXY  
 Olivier de la Chevrotiere, VE2ODN  
 Jennifer de Montigny, VA7TDT  
 Michel de Senneville, VE2OMD  
 Scott Dean, VA3IHU  
 Devon Delisle, VO1DEV  
 Jimmy Desbiens, VA2LFO  
 Douglas Dick, VE4DSD  
 Richard Dixon  
 Adrian Dooley, VE6ADZ  
 Darryl Downey, VA7DDU  
 Adam Drake, VE7ZAL  
 Lachlan Dufton, VE7ZUM  
 Antony Fenton, VA7AQF

Larry Giguere, VA3RSQ  
 Ken Grigg, VA7ELO  
 Yaroslav Grygorov, VA3GYV  
 Daniel Guerin, VA2RTA  
 Julian Gumley  
 Cameron Hall, VE3GVG  
 Robert Harmaty, VE3JYD  
 Bertram Harrison, VA7WWX  
 Yvan Harvey, VE7DVY  
 Alexandre Henry, VE2EDO  
 Steve Hutchings, VE1WTH  
 Akanksha Joshi, VE6AKS  
 Cyan Kim  
 Dennis Knott  
 Kimberly Kostescu, VE3KKA  
 Danny Kukla, VA3HRV  
 Michel Leclair, VE9BGE  
 David Levard, VA2PWN  
 Bryan Li  
 Rick Lloyd, VA1RLL  
 James Loewen, VE4ANE  
 Lee Lull, VE3IEX  
 Brian Lynch, VA3BXL  
 Stephen MacIntosh, VE9SMA  
 Joe Maurer, VE7AWS  
 Shanta McBain, VE7TIT

Jay Melvin, VE7KC  
 Andrew Mogk, VE4AYM  
 Scott Moseley, VE7CMN  
 David Noseworthy, VE3KWP  
 Stéphanie Pelletier, VE2WSS  
 Vanessa Perrier, VO1NES  
 John Platt, VA7NDL  
 Virat Reddy, VE6VIR  
 Jordan Romain, VE3AVA  
 Simran Sandhu, VA7PUJ  
 Ronni Shino  
 Terry Siow, VE3RBU  
 Craig Skinner  
 Ernest Smith  
 Thomas Smith, VE4SI  
 Edward Soorany, VA7WNA  
 Joeseeph J Sparrow, VA4JOE  
 Greg St. Louis, VE3ISL  
 Gerald Stuckless, VO1PS  
 Jay Thompson  
 William Thorne, VE3IDC  
 Stuart Tingle, VA7KLT  
 Quentin Vallin, VA2HSW  
 Joel Vermont, VE3MVG  
 David Wagner  
 Paul Webb, VE7PDQ

Welcome! Bienvenue! | Thank You! Merci!

Edward Spingola, VA3TPV  
 Mike Stafford, VE6MEX  
 Michael Stagg, VA6CNC  
 Edward Staviv, VE3VYT  
 Peter Stec, VE3TOT  
 David Steels, VE3UZ  
 Rob Steenweg, VE1CHW  
 Al Stephens, VE3NXP  
 Bruce Stevenson, VA3BSR  
 Jeff Stewart, VA3WXM  
 David Stewart, VA4DJS  
 Patrick Stoddard, VA7EWK  
 Edmund Strange, VE2MPP  
 William Stunden, VA3ZA  
 Jon Styles, VA3AYD  
 Brian Summers, VE7JKZ  
 Walter Szyz, VE3SYZ  
 Hiroshi Takahashi, VA7LET  
 Raymond Tanguay, VE2RZQ  
 Rainerio Tayco, VE3RYT  
 Malcolm Taylor, VE6YL  
 Art Tendies, VE4AK  
 Leonardo Terceiro, VE6KLE  
 Richard Tervo, VE9AS  
 Jim Thiessen, VA3KV  
 David Charles Thompson, VE3SXY  
 Stephen Tian, VE6TLM  
 Doug Tompkins, VE3IDT

Jason Toms, VE3TBE  
 Jean-François Tremblay, VA2FW  
 Jason Tremblay, VE3JXT  
 Gerry Trueman, VE7GGT  
 Yori Tsuji, VE4ACX  
 Ian Turnbull, VE7TGI  
 Paul Twa, VE7KWA  
 Scott Ullrich, VE7RSU  
 William Underwood, VE1WLU  
 Rosemarie Elizabeth Upfield, VA3RIE  
 Richard Upfield, VA3RMU  
 John Van Egdom, VE6XJV  
 Michael Van Kuyk, VE7KPZ  
 John van Loenen, VA3FVL  
 Rob Van Wyck, VE3FLB  
 Robert Vanderminnen, VA3RMV  
 Pierre Vella-Zarb, VE3VZP  
 Steven Verhoef, VE3WLV  
 Cory Vickruck, VE7KFX  
 Maurice-André Vigneault, VE3VIG  
 Stephen Vinokuroff, VE7WCZ  
 Earnest Vinson, VA3EWW  
 Rob Walker, VE3RWY  
 Scott Waller, VE3OCB  
 John Weale, VA7ZMR  
 James Webb, VE3WA  
 Joel Weder, VE6EI  
 Greg Weir, VE1GWE

Gerald Welch, VE6WCE  
 David Wendt, VE3EAC  
 David Westerman, VE7DVQ  
 Alfred Whitehead, VA3ZTB  
 Donald Whitty, VE9XX  
 Brice Wightman, VE3EDR  
 James Wilkins, VE7UUL  
 Kenneth Williams, VE9KW  
 Wayne Willis, VE5WFW  
 Glenn Wilson, VA3XOG  
 Alan Wilson, VE1AWW  
 Maureen Wilson, VE3MWL  
 Rodney (Rod) Wilson, VE3RXN  
 Bruce Winter, VE7HBW  
 Scott Winton, VA3RSW  
 John Wiseman, VE7BVS  
 Kevin Wittke, VE6KVV  
 Richard Wodzianek, VA7RLW  
 Jeffrey Wood, VE6PAI  
 K. Scott Wood, VE1QD  
 Allen Wootton, VY1KX  
 Robert Wortman, VE9RLW  
 Clayton Wozney, VA3WOZ  
 Leo Yoshinaka, VA3EBI  
 John Janusz Zawierucha, VE3OKZ  
 Fei Zhou, VA3EMQ  
 Jeff Zimmerman, VE3JZT

# Message from RAC Community Services Officer

Jason Tremblay, VE3JXT | Community Services Officer | [community@rac.ca](mailto:community@rac.ca)

## How to Initiate a local Emergency Management Volunteer Program

In this issue I am pleased to present an article by Grant Durfey who currently works as an Emergency Management Program Specialist at the municipal/ regional level in Ontario. In his day to day role, Grant's portfolio covers Emergency Operations Centre preparedness, CBRNE (Chemical, Biological, Radiological, Nuclear and Explosives) CBRNE planning, notification system lead, and responsibility for implementing and coordinating the local Community Emergency Response Team (CERT).

Grant has extensive experience functioning both in EOCs and on-scene during emergencies and takes pride in blending this real-world experience with emerging trends and industry best practices. Grant is a strong proponent of the concept of community resiliency and believes working with the public is one of the best ways to improve disaster preparedness, planning, response and recovery.

The article was originally published as a two-part article in *Avert* magazine and is being used with its permission. Thanks Avert!

### Local Disaster Volunteers

**Grant Durfey**  
– Emergency Management Program Specialist

Many of us as local/ municipal Emergency Managers in Canada benefit from the bottom-up approach taken here. For most disasters, ultimate authority falls to the local Emergency Manager and their department or agency. From most perspectives, this is a good system, giving the local experts with the most detailed knowledge of an area the ability to plan and act on that knowledge. Further support is then provided to the



municipality by the province and eventually the federal government as needed.

While higher levels of government are able to provide specialized resources and equipment, there is a large capabilities gap present. Given that most authority to respond lies locally, higher levels of government in Canada generally do not maintain large operational response/ surge capacities for disasters. Individual ministries and agencies do have their own specific capabilities, but quickly providing a large influx of personnel to assist locally is not what they do. While there currently exists many great non-governmental organizations (NGOs) and independent organizations who can provide assistance, their capacities are limited and their operations, personnel and equipment may be spread over a wide area. The lack of civilian disaster surge capacity in Canada is not a unique realization.

Over the last few months, increasing calls have been made urging the Canadian government to drastically increase its civilian disaster response capacity. While change and improvement at all levels of government is welcome, the federal government is not the only player involved. Even though local funding is generally very limited, municipal governments and organizations can and need to start taking action to ensure their communities are as resilient and prepared as possible, building capacity truly from the bottom up, like Emergency Management (EM) doctrine in Canada calls for.

In lieu of a national, coordinated civilian disaster force, each local EM program is able to recruit and work with volunteers directly on its own. We know that large disasters are going to overwhelm our current workforce, and we know the surge



capacity from higher levels of government is not there, so we need to start proactively embracing the use of volunteers in a disaster.

Generally, this type of volunteering can be broken down into spontaneous volunteers, colloquially known as “walk-ons”, and pre-organized volunteers. While there are many NGOs that provide organized disaster volunteers, we are going to be focusing on those directly affiliated with an Emergency Management program. While this may be presented as a simple answer, there is much to consider when examining volunteer management in emergencies.

While many will advocate relying on the spontaneous volunteers who arrive after a disaster occurs, this does come with some significant risks. If you expect volunteers to come aid from elsewhere, what if the disaster is wide impact, and many other areas are affected as well? This means volunteer forces will be more spread out and take longer to arrive. While the majority of spontaneous volunteers will have good intentions, it is unknown what training, if any they have, the same being said for appropriate PPE, and communications. These difficulties are only further compounded with the issue of command and control, how are these, potentially hundreds, of brand new volunteers going to be folded effectively into your operations?

Instead of the uncertainty of “walk-ons” Emergency Managers need to seriously consider establishing in-house groups of pre-trained and pre-equipped disaster volunteers. Programs such as these are by no means new, and exist across the world in many different forms. In Ontario we even used to see a similar concept funded by the provincial government, funding which was unfortunately stopped some time ago. International models range from the German Federal Agency for Technical Relief (THW), a very technical, specialized group, to the State Emergency Services in Australia, a predominantly volunteer group with extensive rescue responsibility and training. While these groups operate well at a national or provincial/state level, only the largest of municipalities could sustain an organization of their size and technical requirements. For most local Emergency Managers in Canada, adopting a Community Emergency Response Team (CERT) model from the United States is more affordable, realistic, and in some ways, more effective at the local level.

CERTs represent a trained group of volunteers, local to your community, designed and equipped to fit the needs and hazards your program faces. Ranging from a list of people you can call to help, to dedicated equipment and vehicles, a CERT program can be as extensive or limited as your resourcing allows. While much can be learned from the current CERT programs south of our border, a simple copy-paste to a Canadian environment is not the best approach. Instead conduct a gap analysis of your program or area and identify where you would need additional help, and design and train your CERT team to fill that gap. Building a new volunteer program is not easy and many questions need to be answered, from funding and recruitment, to liability and insurance.

Creating a new program can be an intimidating prospect, but it is also a rewarding endeavour with the possibility to have a lasting impact. Starting in 2022 the Niagara Region in Ontario established their own CERT program reporting directly to Niagara Region Emergency Management. As the lead in creating this program, I will walk through our process from inception to the current day and the different challenges we faced.



Niagara Region CERT members training. Photo courtesy of Avert magazine.

Initial concepts for the team began in 2019 as the result of a volunteer management plan review. Many of the concerns raised earlier in this article were realized and we had decided to address them by starting our own CERT program. With a lack of existing CERT programs in Canada, our research started with CERT teams south of the border. This helped to influence some of our initial training decisions and even though we created much of our own material and content, it provided examples of what could realistically be expected from a volunteer group.

This research, combined with a gap analysis of our own area helped us decide the initial skill set and equipment needed for the team. While COVID in 2020 delayed the start of the program and definitely took the majority of our time, we spent 2020-2021 developing the initial training material and working on internal approvals.

The common concerns often voiced when the concept of a new CERT program was raised related to liability and financing. Both these issues deserve consideration, but when examined thoroughly, do not provide a barrier to the creation of a CERT program. Beginning with the liability concern, there are two main aspects to examine, the first being the alternative volunteer source. We know from the previous article and through many recent online articles, discussions and op-eds,

that additional personnel will be needed after a disaster and Canada does not currently have a large civilian surge capacity.

This means most of your surge capacity will constitute walk-on volunteers. While their motives may be good and there are great examples of spontaneous volunteers providing assistance, the lack of training, personal protective equipment (PPE) and operational integration is a concern. Liability is a lot lower if the group you are using is trained, vetted and screened ahead of time with defined policies and roles. An additional mitigating factor is the training provided to the volunteers, this training matches that which staff receive. For example, our volunteers driving dedicated CERT vehicles go through the same driver training as our paramedics. This helps to mitigate any additional risk and provides no more risk than if a staff member were driving the vehicle.

The financial aspect of starting a team is a complex one. Funding can be secured through grants, donations, one-off emergency funding, or proper capital and operational lines. The important aspect to remember is CERT can be scaled to whatever resources are available. While one CERT may have vehicles and technological assets, another may be a list of names to be called should a disaster happen. Both can be effective and aid the community in their own way.



# HAMMOND MANUFACTURING®

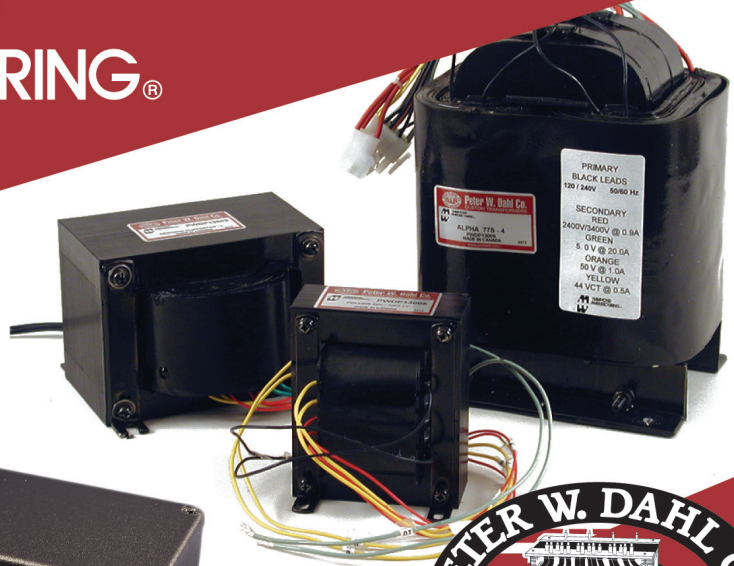

[www.pwdahl.com](http://www.pwdahl.com)  
[www.hammondmfg.com](http://www.hammondmfg.com)

Emergency Managers should also remember that long-lasting programs are built over time, not all at once. Start slow and build one step at a time to achieve the end goal you want, this is the best way to build a lasting program.

Even with secured funding, the primary aspect that will make or break any organization like this are your volunteers. Without enough of the right people, no volunteer program will succeed. The good news is, the right people are out there and wanting to help. In the first year of the Niagara CERT program, a callout was made for 50 volunteer positions, with minimal paid advertising, about \$100 spent on social media ads. In just two weeks, over 300 volunteer applications were received. The volunteers are there, provided the ask is reasonable. One of the most important aspects is to ensure the expectations of the volunteers are not overly strenuous.

The goal for a CERT is to have a true mix of members, not all students, not all middle-aged, not all retired, a blend of the population. For this to work, membership requirements must not be so onerous that

they cannot be effectively balanced with full-time work, school and family life. Additionally, the framing of the volunteer request can go a long way in aiding recruitment. No one will be more interested in helping a community than those who live in it. CERT is meant to be that exact program, helping neighbours, families and friends directly where you live. This type of direct local support appeals directly to people's sense of community involvement.

Once volunteers are recruited, they must also be retained. Looking at our Niagara CERT example case study, there are three main factors used to help keep volunteers active and on the team. The first is a low required commitment but high optional commitment. Niagara CERT members have a low number of required hours they must train per year. However, monthly optional trainings are offered to any member who wants to attend. While some of these trainings are directly CERT related, others are offered based on member suggestions, allowing them to learn about what topics they are interested in.

The second aspect is simple, food. If you are hosting evening training sessions and people are volunteering their time to attend, then make sure to feed them (and more than just pizza every night!). This turns the beginning of a training session into a casual dinner where team members can talk and build bonds outside of formal training scenarios. Lastly, open and honest engagement is key.

Two-way communication between volunteers and those running the team goes a long way to allowing all volunteers, from the newest to the most senior, to feel involved with how the team operates. Many training ideas, exercise scenarios, or public education ideas can come from volunteers and the experiences they have had. CERT is not just about utilizing volunteers to respond, but also providing a direct connection for local emergency managers into their community.

If you are fortunate to have funding and people, the next important question is what should your CERT program do? The obvious answer is to prepare to respond to emergencies, especially since Emergency Response is in the name.

However, a true CERT program will expand beyond preparedness and response and operate in all phases of the EM continuum.

While using CERT as a key response surge resource was the initial impetus of the program in Niagara, a CERT can easily be much more. Niagara's CERT volunteers are trained in traditional response topics, such as first aid, basic search and rescue, incident organization, radio procedures etc. However, based on a gap analysis conducted, specific needs were also identified. CERT worked with the local ARES/ACS group to start a CERT-Auxiliary Communications Unit, bringing Amateur Radio operators and systems directly in-house. This is supplemented by satellite internet terminals and deployable radios stations all run by CERT volunteers.

One of the most impactful aspects of the Niagara CERT program is the dedicated Public Education Unit. Working with the local safety village, starting in September 2023, specially trained CERT volunteers will provide weekly education to elementary-aged students on severe weather and emergency preparedness. This helps the preparedness aspect of CERT flow from the volunteers and program being prepared to increasing general preparedness of the public.

The last aspect to touch on is an example of a CERT response. Niagara CERTs' first deployment was on the morning of Christmas Day 2022. An extremely severe blizzard had hit Niagara over the previous 48 hours resulting in extreme flooding, icing, snowfall, and power and cell phone outages. It was determined Christmas morning that three evacuation/warming shelters would need to be opened immediately and would end up staying open for three days.

Niagara CERT is not the primary shelter operator in Niagara, this responsibility is contracted out to another NGO. However, on Christmas morning, at the tail end of a blizzard that completely closed roads throughout the entire Region, volunteer availability was an issue for this provider. The contracted NGO was unable to staff the shelters fully due to the storm impacts, and many of the staff who would normally assist were also unable to attend. This led to a CERT callout and with

all of the CERT volunteers living locally, many were able to make it in and help staff the shelters.

This is a perfect example of the need to have a depth of personnel when it comes to incident response and the need to have a core group of volunteers local to the area, available at any given time. This also means it is important to consider how large your CERT team is. In Niagara the assumption is made of roughly 33% available volunteers at any given time, however, it is recognized this will be less around key holidays. With this in mind, a team size of 150 volunteers is maintained to ensure an appropriate number will always be available.

While no two CERT programs may be structured or run the same way, they all provide the same function; a local, trained personnel reserve, integrated with your community and your local emergency plans. This can be executed in many different ways, but as long as that function is kept in mind, then a CERT will benefit any community. By expanding CERT use beyond just response, CERT volunteers can truly represent a force multiplier for Emergency Managers everywhere.

## Operation Dark Skies

On October 16, the Regional Municipality of Niagara conducted a full-scale exercise named Dark Skies 2023, which aimed to provide training for the upcoming total solar eclipse on April 8, 2024. It is estimated that around 700,000 people will visit the region to witness the eclipse, which could result in traffic congestion, communication disruptions, and add a strain on local resources.

During the Dark Skies simulation event, CERT AuxComm was assigned three tasks: establishing a radio room at the Regional Emergency Operations Centre (REOC); establishing radio communications at a forward operating base using the CERT-01 support vehicle; and establishing a remote operating station located in an outdoor shelter at a conservation area on the outskirts of the region.

The exercise provided an increased understanding of local operations and protocols and insight into future deployment strategies. Unofficially, it is estimated that the use of CERT and CERT

AuxComm personnel during the event saved a considerable amount of money for the region (est. \$70,000) compared to tasking these operations to paid personnel. CERT provides the community with an influx of trained and skilled volunteers, and the specialization of a communications team opens the door to numerous potentials through future training programs and planning.

The Emergency Management scenario for the total solar eclipse on April 8 will provide an excellent opportunity to test the new Auxiliary Communications Service. The test will focus on deploying rapid response teams to designated staging areas in Southern Ontario and assessing the potential complications that may arise during this process. These teams have the potential to become active support teams within the regional response plan.

Furthermore, a test of Ontario North Emergency Operations Centre activations and communication system will be conducted in partnership with Emergency Management Ontario's (EMO) planned response priorities. The Auxiliary Communications Service will actively assess potential complications with field and EOC communications between Northern Ontario and the Provincial Emergency Operations Centre (PEOC). This full-scale exercise establishes an all-hazards provincial communications plan to support EMO's plan for a "Safe, Practiced and Prepared Ontario".

As described earlier, the October 16 Dark Skies exercise demonstrated that the Amateur Radio Service remains viable in today's ever-changing communications environment. By deploying more than 50 trained operators, voice and data communications were provided directly and indirectly to the PEOC from Northern Ontario and parts of Manitoba to Peterborough and into the Niagara Region without using the internet.

Additionally, the Winlink Global Communications System deployment has improved and evolved communication abilities. Auxiliary Communications can serve as a backup plan when primary communication systems fail. While Auxiliary Communications utilizes technologies similar to those used by commercial and government agencies,

the diversity of equipment, operator training in repair, installation and customization, and the range of frequencies and operating modes available to Auxiliary Communications guarantee that communication can continue even in worst-case scenarios. Even in the most extreme conditions, a significant percentage of Auxiliary Communications stations are expected to operate in some capacity.

Emergency planners must balance cost versus benefit, which means that emergency plans provide communication capacity to meet most needs in most situations. However, problems arise when emergency demands exceed planned capacity or the emergency itself affects the availability of critical communication resources needed to manage it. Radio Amateurs of Canada intends to collaborate more with agencies with jurisdiction, such as EMO, to understand communication requirements better and educate local Community Emergency Management Coordinators on the benefits of the Auxiliary Communications Service.

While provincial, municipal and other agency communication systems are robust and well-suited to most emergency requirements, they are not easily scalable in times of crisis. Extra transceivers, repeaters, frequencies and personnel familiar with communication procedures may be challenging to obtain in time to be helpful. During the upcoming solar event on April 8, it's essential to consider how many Cellular on Wheels services will be available and whether they can be deployed and set up before the event begins.

Auxiliary Communications is one possible solution if the demand for communication exceeds capacity. The Amateur Radio community provides many experienced telecommunication operators and equipment. Furthermore, the frequency diversity available to Auxiliary Communications far exceeds anything available on commercial or government radio systems.

Auxiliary communication capabilities can also be customized quickly to meet unusual needs. The radio operators involved in Auxiliary Communications are skilled in installing, configuring and repairing the radio systems they use. They can quickly adapt technologies and systems to meet unforeseen requirements.

Auxiliary Communications can create high-capacity ad-hoc networks anywhere they are needed, with very little lead time. The deployment of this capability is the province's responsibility and how it promotes the use of these services to the local Community Emergency Management Coordinator. These Coordinators are usually volunteers who work for a municipality and have little training or disaster experience. They generally follow provincial doctrine and plans to the letter to save time developing their operation system or plan.

If the Emergency Management Office of Ontario decides to support and assist in the future development of Radio Amateurs of Canada's Auxiliary Communications Service, it could follow a similar approach to that of the Community Emergency Response Team (CERT) of the Regional Municipality of Niagara. This would involve setting up a provincial Emergency Response communications program that comprises trained and certified volunteers who can assist their community during times of crisis

or disaster. Once an auxiliary communication response team is established, the safety and resilience of the provincial municipalities will be significantly improved. Radio Amateurs of Canada is willing to collaborate on such a project with provincial authorities and meet their requirements under the Provincial Emergency Management Strategy and Action Plan.

## **New Section Manager: Ian Clarke, VE7KCP**

I would like to welcome Ian Clarke, VA3KC, as the new Section Manager for the Ontario Golden Horseshoe Section effective January 1.

Ian has previously served as the District Emergency Coordinator for Toronto since December 2022. We welcome him to the new Sectional Council and look forward to working with him in the field. Ian provided the following bio:

"My father, now a Silent Key, originally had the call VE7KCP. He acquired his Amateur Radio licence in the 90s for use while on his seafaring cruiser for ship to shore communications. I found this very intriguing and although he was not active in his later years, I was fortunate enough to ask if I could use his call suffix as my own when I passed my exam. He eagerly agreed.

Although not formally educated in wireless communications, I did have a consulting contract with a company that designed, built and sold internet modems and later invented DSL for internet use in the early years. It was through this exposure and acquired technical understanding of wavelengths, propagation, attenuation and other attributes of both wired and wireless communication that I undertook a self-study program and acquired my Basic with Honours designation all within 30 days.

Almost from the very beginning of my Amateur radio career, I joined the Amateur Radio Emergency Service (ARES) in Toronto. I volunteered with Malcolm Kendall and learned a lot about volunteer organizing and the importance of emergency planning. We both volunteered for the 2015 Paralympic games and we were chosen to create, design and deliver the 'comms' protocols for the 22,000 volunteers. We created a 'train the trainer' program so we could deliver and get the entire volunteer organization trained in time for the games in July of 2015. I was assigned to manage the daily communications at the largest venue of the games – the Enercare Centre at the Canadian National Exhibition. It was the highlight of my volunteering to date.

I have been involved with ARES/ACS ever since here in Toronto. I also joined the Toronto Amateur Radio Club several years ago and have served as its Vice-President since 2021. My interest in the Section Manager role lies in both the current situation as well as the future. Understanding the role that ACS will play and translating that into operational capabilities will take advantage of many of the skill sets I developed in my own business."



# Community and Emergency Service Reports (ACS/ARES)

## BRITISH COLUMBIA / YUKON:

### Acting SM: Bill Gipps, VE7XS

A/SM: David Musselwhite, VY1XY

A/SM: Neil King, VA7DX

STM: Al Ross, VE7WJ

SEC: Acting Al Munnik, VA7MP

SEC: Terry Maher, VYIAK (Yukon)

OO: Dennis Wight, VE7IJJ

ACC: Karla Wakefield, VA7KJW

CEC: Gursimran Gill, VA7GUR

SBM: Fred Orsetti, VE7IO

Website: [www.va7mpg.ca](http://www.va7mpg.ca)

### September-October SM Report:

If you have an item of interest to include in this section, please send it to Acting Section Manager Bill Gipps, VE7XS, at [bill.gipps@gmail.com](mailto:bill.gipps@gmail.com) and to the TCA Editor at [tcamag@yahoo.ca](mailto:tcamag@yahoo.ca).

### Operation Nanook and Noble Skywave David Musselwhite, VY1XY

The Government of Yukon participated in a territory-wide emergency preparedness exercise, Operation Nanook-Tatigiit 2023, from October 23 to 26, together with partner agencies and governments.

Operation Nanook-Tatigiit is an interagency territorial exercise that takes place yearly in one of Canada's three territories. Tabletop exercises are valuable learning tools which contribute to enhanced emergency planning and coordination. This year's exercise involved responding to a simulated winter storm causing widespread highway closures, power outages and other incidents across southern Yukon.

The Yukon Amateur Radio Association (YARA) manned our radio station which is beside the Emergency Measures Organization (EMO) station to pass any messages that they wanted. At the same time Yukon Rangers held an overnight exercise called Operation Noble Skywave with the purpose of contacting other Rangers in Canada on the military HF frequencies. YARA was included in helping them to set up their radio antennas.

### High Altitude Balloon Test Adrian Stimpson, VE7NZ

On November 11, the North Fraser Amateur Radio Club held a special "Remembrance Day Super High Altitude Balloon Launch with APRS & Cross-Band Repeater" event.

The balloon rose to over 100,000 feet before bursting and then returned to ground by parachute and hopefully will be recovered. It drifted east as planned and landed in the Okanagan. Total flight time was three hours.

The payload included a 1-watt APRS transmitter using the call sign VE7NFR-11 and a crossband 5W UHF/VHF repeater so people could talk to each other using the balloon as the repeater. Telemetry included lat/lon/pressure/temp (see [aprs.fi](http://aprs.fi) and look for VE7NFR-11). However, telemetry failed at 9,000 metres due to what was believed to be damage to the antenna during the launch.

Contacts were made as much as 600 kilometres apart with the most distant stations including Coeur D'Alene, Indiana, southwest of Seattle, Nanaimo and Kelowna using just a simple handheld. In all more than 37 unique stations were logged.

Earlier launches (without repeaters) have been funded by Adrian, VE7NZ, Scott, VA7SL and Steven, VE7SLZ, but a GoFundMe campaign is being started so that more experiments can be done taking into account the lessons learned from this launch. Details on that, a recording of the downlink, and other info can be found at [www.ve7nfr.com/pico-balloons](http://www.ve7nfr.com/pico-balloons).

### Public Service Honour Roll

#### September:

VE7XLH: 78; VA7MPG: 160; VE7GN: 110;

VE7WJ: 76

#### October:

VE7XLH: 81; VA7MPG: 290; VE7GN: 115;

VE7WJ: 84

---

### TERRITORIES:

#### SM: Vacant

### September-October SM Report: RAC Community Services Officer – Jason Tremblay, VE3JXT

I have been working with Amateur Radio enthusiasts in Yellowknife and Cambridge Bay to create training programs for remote groups in the territory and to develop future communication plans.

I want to express my appreciation to Ron Thompson, VE8RT, for his commitment to community development through Grassroots Emergency Communications Operations (GECO) and the Wanderers Amateur Radio Club for providing recent updates on the wildfires and flooding this season.

As a Community Services Officer, I had the opportunity to meet the group during a weekend breakfast, where we discussed the challenges and dedication of Amateur Radio operators in the Northwest Territories (NWT). Based on this meeting, we have developed strategies to support

future efforts in the Northwest Territories. RAC is working with two individuals for the Section Manager position.

### Northwest Territories and area – Paulo Ranzani, VE8PR

As a result of the last wildfire incident here in Yellowknife, I requested a Starlink access to the internet to be used as a redundancy of the internet connection provided by Northwestel. It is not uncommon to have fibre optic cables destroyed by the temperatures or wildfires so this satellite link will be used as a backup for RAC/ARES and NWT 9-1-1 operations.

We still have problems with our repeater Echolink connection, but the repeater itself and the AllStarLink are working well.

---

### ALBERTA:

#### SM: Ron Pettigrew, VE6RWP

SEC: Brian Davies, VE6CKC

STM: Don Moman, VE6JY

OO: Don Moman, VE6JY

[wp.rac.ca/ares-alberta-yellowknife-nwt/](http://wp.rac.ca/ares-alberta-yellowknife-nwt/)

### September-October SM Report:

SM Ron Pettigrew, VE6RWP and a few local Amateurs from central Alberta – Wenn, VE6MLC, Ed, VA6EJP, Jim, VA6JC, Melanie, VE6MSH, Kirby, VE6MFX and Star, VE6SCC. worked with the First Leduc Scouts to run radios and promote Amateur Radio at their Jamboree On The Air (JOTA) Camp on October 21. There were 55 youth attending.

### Red Deer – Stephen Lee, VA6SGL

The Sunday evening VHF net continues to be well attended. An additional net controller has been recruited the group now has four net controllers.

### Grande Prairie – John Gilje, VA6JG

I am sad to report the passing of Dennis Bancosco, VE6ATC (SK). He provided repairs of our radios for our club at no charge and also looked after our repeaters for over 50 years. He also allowed us to use his sites and gave us the site in the Saddle Hills plus the tower at no charge. We are uncertain as to what will happen to the down repeater on his site in Beaverlodge, and we have been informed that the city of Grande Prairie has left the site in Grovedale, where our XN repeater is located. These are challenges we will have to deal with.

The last time I spoke with search and rescue, they were having difficulties with the newly trained crew who were given gear. They are refusing to go out on calls,

and we are facing similar problems. I was only able to find one volunteer for the Peace Area Ride for the Disabled. For the past several years, we have had 12 Amateurs participating in this event. The Grande Prairie Volunteer Association advised that most clubs are experiencing the same problem.

#### **Medicine Hat – William Baugh, VE6CTM**

The Medicine Hat Amateur Radio Club is now located in the meeting room of the Forty Mile Gas Co-op Limited company at 254 7th Street in Dunmore. We would like to thank the company for letting us use their space. We no longer have a permanent standalone operating station with HF and 2 metre / 70 centimetre abilities.

The club has discussed how we could respond to a civil emergency and have set in place a plan to respond from our individual stations at our homes. Many of the club members have completely equipped stations (HF, 2 metre, 70 centimetre, internet).

#### **Calgary – John Jardine, VE6ONO**

On Saturday, September 16, five members of ACS Calgary (formerly Calgary ARES) took part in the Killarney Glengarry Community Association Safety Day event between 1 pm and 3 pm. On Wednesday, October 11, four of us met in person.

On Saturday, October 14, three of us held an SET on 146.580 MHz and sent Winlink messages. On Wednesday October 25 we held our monthly simplex net.

– SM Ron Pettigrew, VE6RWP

---

#### **MANITOBA:**

##### **SM: Jan Schippers, VE4JS**

STM: Jan Schippers, VE4JS

SEC: Vacant

DECs: Jeff Dovyak, VE4MBQ (Capital Region and CanWarn); Gord Snarr, VE4GLS (South-East Central Region / South-West Region); Wayne Warren, VE4WR (North Region and Special Projects); Vacant (North-Eastern Region); Vacant (North-West Region).

ECs: Ron Willisroft, VE4QE (Selkirk and District); Bill Boskwick, VE4BOZ (RM of Grey, RM of Dufferin & Town of Carman); Jason Coombe, VE4JYC, (Brokenhead ARES); Grant Delaney, VA4GD (LGD of Pinawa and surrounding municipalities)  
wp.rac.ca/ares-manitoba/

##### **September-October SM Report:**

##### **Winnipeg ARES – Jeff Dovyak, VE4MBQ**

At our October meeting, Don Mackinnon, VE4DJ, spoke about “Volunteering in the 21st Century”. Thank you Don for a great presentation!

#### **Winnipeg ARC 2023 Fall Fleamarket**

The Winnipeg Amateur Radio Club held its Fall Fleamarket on Saturday, October 14 at the Dakota Community Centre. Amateurs from throughout the area came out to see what was up for sale and to enjoy some eyeball QSOs. Doors to the fleamarket opened at 9 and over 70 Amateurs were in attendance to look over the vendor tables that neared almost 20. Tables were packed with great gear and good deals were made.

WARC and their cable shop, the QSL Bureau and the Winnipeg Digital Repeater Group as well as a test bench manned by Yori, VE4ACX, were represented at the market. Thank you to all who volunteered: Jamie, VE4JHT, Nicholas, VA4NJF, Harm, VE4HZ, John, VE4IM, Brad, VE4BSC, Sue, VE4SYM, Fred, VE4TRO, Andrew, VE4DRW, Yori, VE4ACX, Gary, VE4GG, David, VE4DL and Cary, VE4EA.

They all made the task of setting up, obtaining prizes, selling tickets and greeting guests a breeze. Thank you to all the vendors that supported WARC with the purchase of tables and to the Dakota Community Centre for providing the space for the event. Thanks to everyone who came out to support WARC for their final fleamarket. As the organizer, I hope all who attended had a good time and enjoyed the market.

#### **Traffic Totals**

**September: 2**

**October: 4**

---

#### **ONTARIO – GOLDEN HORSESHOE:**

##### **SM: Ian Clarke, VA3KCP**

##### **September-October SM Report:**

My name is Ian Clarke, VA3KCP and it is my honour to have been appointed as the new Section Manager for the Ontario Golden Horseshoe Section as of January 1, 2024. The region spans Durham, Toronto proper, York, Peel, Halton and Niagara. As you can imagine it is a busy area with many exciting things happening across it.

I'd like to recognize my predecessor Rick Harrison, VA3NV, for a very long and dedicated tenure. Keeping the Section going through COVID was no small task.

From the new CERT program in Niagara, to Winlink trainings in York to meetings with municipalities and other agencies in Halton and a lot more, the GH section has some of the most innovative and creative operators in the hobby. By now you should be aware of the Auxiliary Communications Service (ACS).

If you're not, take some time and head over to the RAC website to learn about it. This organization will be the interface to our served agencies when they call us out for assistance. Its structure is different from ARES as is its mandate. 2024 is the year that we really embrace it. There will be new appointments, new training opportunities and new ways for us all to be far more effective in how we volunteer our skill sets in an emergency.

The purpose of the name change follows what we actually do. We are the wireless communications volunteers that come with standardized, comprehensive training when called out by our served agencies. Because of this, we can be deployed both locally and further a field knowing that our training, knowledge and capability will be the same where ever we are asked to help.

The organization and its mandate is substantially different than ARES too. Don't worry, we will still need you and your skill sets more than ever, but our responsibility will be to make the very best use of them. We will equip you with relevant, comprehensive training in several different focused areas. Its exciting. It's a much improved organized and a vastly more efficient way of providing our critical service in an emergency.

If you are a member of ARES and I know there are lots across the section and you are interested in how you can volunteer with ACS, please reach out via email to k9lyfgrd@gmail.com. ACS has several new positions that the GH section needs to fill with energetic, qualified people. If you are keen on being involved with a group of like-minded people that are ready and able to serve various agencies in an emergency, we'd like to hear from you.

---

#### **ONTARIO NORTH:**

##### **SM: Allan (AI) Boyd, VE3AJB**

ve3ajb@vianet.ca

STM: Patrick (Pat) Dopson, VE3HZQ

dopsonp@vianet.ca

SEC: Stiig Larsen, VE3LBX

slarsen@vianet.ca

OBM: Paul Caccamo, VA3PC

va3pc@ciinet.org

Web: <http://ontario.racares.ca>

##### **September-October SM Report:**

It has been a busy a time for the Northern Ontario Section with lots of changes. Amethyst DEC Warren Paulson, VE3FYN, has decided to step down from his position due to personal commitments. I want to take this opportunity to thank Warren for all his years of service as District Emergency Coordinator for the Amethyst District. Warren did an amazing job keeping the Northwest

connected and brought in the use of Winlink training and procedures that are now being used by Amateurs across Canada and he has indicated that he will remain active.

I am very pleased to announce that Woody Linton, VE3JJY, will be the new DEC Amethyst District. Woody has served as EC Nestor Falls for several Years. He is a retired Ontario Provincial Police Officer who served Northern Ontario and has extensive experience in Winlink and Canadian Forces Affiliate Radio System (CFARS) Communications. He will be a great representative for the district. Welcome to your new position Woody! It will be an honour to continue working with you.

Northern Ontario was involved with the National SET Operation Dark Skies and many of our Northern EOCs were activated. Voice and Winlink, along with VHF and UHF communications to Toronto and the Provincial EOC, were conducted with the Provincial Communications Linked System net. A full debrief report will be provided once the reports are received from all sections.

#### **Albany District**

##### **Elliot Lake – EC Bob Young, VE3ETE**

Our Tuesday evening net participation was lighter, averaging 31 in September and 34 in October. In September, formal traffic messages were the usual number, but much was lost due to the reinstallation of Winlink Express. Our NCS Earl, VE3AB, continues with the CW and SSB nets on 144.200 MHz, followed by the FM net on Tuesday nights, to give our more numerous FM stations first chance at checking in. Earl has been operating from the height of the Fire Tower location for the period, with some DX success. I have been NCS for the C4FM digital net when Earl has other responsibilities.

The local CEMC continues to be copied with our Winlink weather reports. During the period I attended eight Manitoulin ARC AGM membership. All were well attended. I checked into the ProComm net 13 times. There were 9 XRF-103 reflector check-ins (D\* Digital Mode) during the same period.

I also checked into ONTARS, on Sunday mornings, nine times and into the 40-metre NWO Ares Net on Wednesdays three times. After a lot of reading, talking to other Amateurs, I was finally able to get the FTDX10 working with VARA HF modem for Express sending of Winlink messages.

Halloween fell on a Tuesday this month, so we cancelled the nets and the visit to MacDonald's. Formal traffic messages were back to the usual numbers. Four of us went up to the Fire Tower and installed a temporary J-pole antenna at a higher elevation than the previous antenna. We have been having noise causing desense of the repeater receiver, and the new antenna worked like a charm. We had rave reviews for the quality of the repeater reception and transmission to the furthest stations checking in. Unfortunately, we couldn't keep it there, as it was only temporary. I was able to take part in the CQ WW DX contest and bettered my previous year's score.

##### **Sault Ste Marie – EC Dave Rowlinson, VE3ZDR**

Monthly meetings are back on schedule and the turnout has exceeded expectations. The September meeting had a Winlink 101 demonstration to show how Winlink is a valuable tool for emergency communications. Brent, VE3OTL and Dave, VE3ZDR, attended the AuxComm Position Task Book training / Completion with our Michigan counterparts. Completed and signed Position Task Books are in transit. It was a great training event.

It was a busy October for the Sault team. The month started with Dave, VE3ZDR, attending an ICS-200 course offered by the City of Sault Ste Marie, then the monthly club meeting included a seminar and First Aid and CPR.

The busiest activity was the Simulated Emergency Test in which the group supported both the Canadian and the Chippewa County events. On the Canadian front, we submitted Winlink Check-ins and Check-outs and monitored for any traffic directed our way. The Chippewa County event was much more hectic, providing net control backup for the Chippewa EOC, relaying traffic from "shelters" to the EOC, right through to providing simplex relay from stations only a few miles from each other that couldn't directly communicate, but were able to connect to the Sault ON EOC. The biggest takeaway from the SET is to work with the team to generate a Sault Ste Marie centred PACE plan for future exercises and events.

#### **Amethyst District**

##### **Thunder Bay – EC Brad Harris, VE3MX**

We have two new members – Eric, VE3XET and John, VA3WJX – and both will be my Assistant Emergency Coordinators. The monthly EC/AEC zoom meetings are being

held on the last Thursday of each month and the EOC net is on the first Thursday of each month. This net is a closed net and is for Amethyst District EOCs only.

The Thunder Bay EOC is working on being fully operational. In October there was no internet and some RFI on 80m. A heavy-duty stand was built for our mast on the EOC roof; it has been installed with the help of the fire hall and their bucket truck.

Welcome to new Amethyst District DEC Woody, VE3JJA and thanks to Warren, VE3FYN, for doing a great job.

##### **Atikokan – EC Warren Paulson, VE3FYN**

On behalf of Atikokan ARES, the Atikokan Amateur Radio Club secured a five-year agreement with the Town of Atikokan to use space in the Town Hall and on their property for the operation of the EOC (VA3EOA). Atikokan ARES had been using this space and space in the previous Town Hall for some 20 years, but under a verbal agreement. Routine maintenance was performed at the VA3EOA EOC station in October.

##### **Fort Frances – EC Rod Davis, VE3RYD**

The month of September was quiet. We participated in weekly nets. I tried to participate in the RAC seminar Zoom meeting, but couldn't get in. Other than that, enjoying the warm weather. In the month of October, we participated standard ARES/ACS nets and were part of Operation Dark Skies. Warren, VE3FYN, retired and I want to thank him for all his help. We also sat in on our EC Zoom meeting at the end of the month.

##### **Kenora – EC Chris Bigelow, VA3ECO**

On October 16 the Kenora EOC and other Northwest Ontario stations took part in a province-wide SET called Dark Skies. We passed messages up to 1400 kilometres using voice, and digitally using Winlink Vara HF. Two observations that I found interesting were that sometimes the Winlink messages worked when conditions were too weak for voice, and that on one occasion both Winlink and voice traffic happened simultaneously, and although slow were both sent successfully.

##### **Sioux-Narrows – EC Nestor Falls – Woody Linton, VE3JJA**

In October we had one power outage because of heavy snowfall resulted in local Amateurs connecting on the Sioux Narrows repeater and advising each other of conditions. CanWarn was not officially activated. The highlight of the month was

Operation Dark Skies. The Primary EOC ARES/ACS station was activated at 0730 hours CDT and Operators using the EmComm Charlie Frequency passed and relayed Phone & Winlink (Vara) messages to the SEC and the Provincial Emergency Center liaison station. The station then stood down at 1400 CDT. On our part it was a meaningful Exercise.

#### **Dryden – EC Bob Ernewein, VE3YDN**

Dryden participated in Operation Dark Skies and weekly nets. The annual "Laura Howe Haunt" event was held as part of Dryden's Fall Fest. Six members participated in positioning/crewing our Emergency Response Unit to the registration and finish line area. I provided portable area and security (with OPP participation) lighting for the start area. The organizers this year had about 420 participants as opposed to 732 last year. This was seemingly due to offering a pre-registration but ending up with considerable "no shows". The ARSD provided communications for the trail and checkpoints and the start and finish lines. The organizers were again thankful for our participation.

#### **Killarney District**

##### **Manitoulin Island and North Shore – Acting EC Allan Boyd, VE3AJB**

The Manitoulin Amateur Radio Club participated in the Haweater Parade providing traffic control and communications for the Little current Lion's Club. We were part of the National SET Operation Dark Skies and had our EOC activated relaying important traffic from Northwest Ontario to the Toronto core area. We also participated in the Worldwide CQ Contest at the end of October having many stations activated.

##### **Sudbury – EC Marc Savignac VE3SNA**

At their Annual General Meeting, the Sudbury Amateur Radio Club elected a new executive: President Frank, VE3AC; Secretary Vic, VE3KBU; and Treasurer Luc, VE3AR. Good luck guys and thank you for stepping forward.

#### **Magnetawan District**

##### **North Bay – Bill Gibson, VE3TGI**

On September 30, North Bay ARES provided supplemental communications for the Run-Off-the-Grid competition held at the Nature's Harmony Eco-Lodge, located 25 kilometres north of Mattawa. The six ARES members – VA3CMX, VA3IGH, VE3KOJ, VE3LOR, VA3SK and VA3PC – provided bib numbers and timing info from three checkpoints to start/finish.

The cross-country race had 162 entries in three different distances. Communications was simplex using six portables, one mobile and one base radio.

– 73, SM Allan Boyd, VE3AJB

#### **DECs Reporting:**

**VA3s:** PC

**VE3s:** JJA

#### **ECs reporting:**

**VA3s:** ECO

**VE3s:** AJB, ETE, JJA, MXJ, RYD, SNA, TGI, YDN and ZDR.

---

#### **ONTARIO EAST:**

##### **SM: Michael Hickey, VE3IPC**

Email: ve3ipc@gmail.com

SEC: Michael Hickey, VE3IPC

STM: Vacant

OBM: Paul Caccamo, VA3PC,

va3pc@ciinet.org

Web: <http://wp.rac.ca/ares/>

#### **September-October SM Report:**

Now that autumn is over and antennas of various types and coaxes are all buttoned up, Amateurs who prefer to remain on the warm side of the glass will be able to focus with radio operations on various types of radio equipment and using various modes of communications. Propagation should be very good over the winter months for those DX contacts we all seek to have.

#### **ARES EmComm Group leadership reports:**

##### **Submitted by Prescott-Russell**

##### **(PR-ARES) Group Coordinator**

##### **Lance Peterson, VA3LP**

Prescott-Russell (PR-) ARES participated in the national SET on October 16 and covered a large portion of the United Counties of Prescott and Russell (UCPR). They were active in four places. At the Municipality of Russell Township "EOC Annex" in Embrun, Leo, VE3EBI and Lance, VA3LP, operated VHF/UHF voice and VHF Winlink. At Nation Municipality, Mick, VA3PAI, set up and operated the PR-ARC Club Trailer. At the alternate UCPR "EOC 2", Gilles, VE3NPI, and Jim, VA3KV, operated from inside the ambulance building in Plantagenet. At the main UCPR "EOC 1" at the ambulance building in Hawkesbury, Mike, VE3IPC, and Pierre, VA3HWK, activated the county owned station equipment.

Al, VE3BOA, was at home in Vankleek Hill and provided additional communications oversight from one of the highest points in UCPR county area. Stuart, VE3SMF, was also active from his home west of Ottawa on Winlink HF monitoring the communications from Northern Ontario to the PEOC in Toronto as backup.

The exercise started at 10 am. All stations checked in through the primary repeater VE3PRV 147.330 MHz in Hammond. Once logged in, the group moved from repeater to repeater and checked the availability to communicate throughout the county through alternated repeaters. A check on our ability to communicate direct, antenna to antenna, on simplex (SX) was also initiated. This proved to be a concern at that time, but all stations had the ability to relay for those that could not be heard. Al, VE3BOA, was of particular value as he was able to hear all stations in the County.

After the communications checks, the stations had messages to send and receive to practice our ability to perform this task. The stations in Embrun, Plantagenet and Hawkesbury, as well as Stuart from home, initiated messages via Winlink utilizing the Winlink forms.

At 2 pm the net was closed and all stations dismantled their respective systems and headed home. A debrief was held at the next PR-ARC club meeting.

#### **Submitted by PR-ARES Leadership member & Liaison with the UCPR Mike Hickey, VE3IPC**

On October 11, PR-ARES Group leadership members Gilles, VE3NPI, and Mike, VE3IPC, met with the the UCPR's IT and Communications Officer Maxime at the secondary EOC in Plantagenet to test the Kenwood TM-V708A dualbander radio and equipment. The Diamond X-500 dual band antenna visibly looked to be intact, but had not been tested since the start of the pandemic in 2020. The tests went very well on both bands and were able to raise all the repeaters we normally were able to in the past with the same signal and audio reports. This is very good as this is a 20 year + old antenna in a low line area. If we are to do DMR from here we would need to have a duplexer, an antenna switch and a patch cord for a personal DMR HT.

Both County EOCs were activated at the same time for the first time ever on October 16 for the annual SET. Mike, VE3IPC and new Amateur Pierre, VA3HWK, met at the primary County EOC in Hawkesbury for the SET Exercise. The Kenwood TM-V708A dualbander radio is permanently installed in the radio room and seemed to work fine for the more local repeaters but a problem occurred several times when trying to activate the more distant repeaters. Al, VE3BOA, a local Amateur helping with the exercise, reported that on simplex (SX) the signal was varying intermittently and this provided a clue as to why the distant

repeaters were difficult to raise, which was not normal. The radio takes about 30 + minutes before working again at high power and then all repeaters were able to be reached. It is now believed that this is due to a poor contact in the final RF stage when the radio is cold. Once the radio is fully warmed up, after some 30 minutes, the full RF output is then able to reach the more distant repeaters, as per normal.

#### **Submitted by Peterborough ARES – Assistant GC John deLagran, VE3VL**

September was a busy month. Group members were unable to test the City EOC's radios due to ongoing construction of the new communications equipment at Fire Station #3. VE3EMA, VE3BLM, VE3IQZ and VE3VL were able to test the radio and generator in the Peterborough County Special Operations / ESU trailer.

Thirteen members of Peterborough ARES/ACS participated in an all-day training session on September 16. Special thanks to Fire Chief Chuck Parsons, VA3NY, for providing his EOC in Otonabee – South Monaghan Township as the venue for the training.

Peterborough ARES/ACS gained four new members in September. Warm welcome to Henry Schmied, VA3ZRS, Tom Kennedy, VA3TVK, Randy Neals, VE3RWN, and Debora Thomas, VE3EKG to our ARES Group.

Clay Youman, VE3YCL, created a new website for Peterborough ARES/ACS at <https://ve3pbo.ca/PARES/>. The new website better reflects the changes to ARES as we move towards ACS.

The Peterborough ARC and ARES members provided radio communications for the Head of the Trent Regatta on September 30 to October 1. Three stations were set up to cover the 5 kilometre course providing race organizers with progress reports and message handling for 10+ hours each day. This event draws rowers from across Ontario, Quebec and beyond. There were 573 boat entries from 54 clubs. Manning the radios this year were: Clay, VE3YCL (Activities Director), Rick, VE3IQZ, Rick, VE3RKY, John, VE3VL, and XYL Lou, Darren, VA3PDJ, Barry, VE3BLM, Dave, VE3SD, and Nina, VE3IRK.

There were an average of 13 check-ins to the weekly net in September.

On October 19, group members VE3EMA, VE3EKG and VA3TVK checked the radio and antenna at the Peterborough County EOC located at the County Court House. VE3BLM provided signal reports as they

tested various repeaters throughout the region. They also performed a Winlink test to VE3KPG Winlink RMS Gateway. Both radio and antenna performed as well as expected.

On October 25, Peterborough ARES/ACS completed an Emergency Field Training Exercise with the Municipality of Selwyn. Fifteen members of P-ARES participated in the exercise in eight locations throughout the township. VE3EMA and VE3VL gave a presentation to the Selwyn Municipal Emergency Control Group (MECG) at the EOC, prior to the start of the exercise. Halfway through the exercise, the MECG observed our operations from the EOC. The exercise included Winlink with one message sent by EMO Severn Sector Field Officer Eric Thibaudeau addressed to the Selwyn CEMC. Members of the Selwyn MECG were very impressed with our demonstration and have committed to installing an antenna and coax to their EOC for ARES/ACS use.

The following participated in the Emergency Field Training Exercise: VE3EMA, VE3VL, VE3BLM, VE3IRK, VE3IEL, VE3EKG, VA3OMW, VE3RKY, VA3NW, VE3YCL, VA3NPW, VE3XOE, VA3TVK, VA3ZRS and VE3RWN.

The following completed the 2023 ARES/ACS Part One (in-class) and Part 2 (Field Training Exercise) Training: VE3EMA, VE3VL, VE3BLM, VE3IRK, VE3IEL, VA3NW, VE3YCL, VE3XOE, VA3TVK, VA3ZRS and VE3RWN.

There were an average of 14 check-ins to the weekly net in October.

#### **Submitted by the RCW-ARES GC Bob Howard, VE3YX**

The Renfrew County (RCW)-ARES Group Coordinator Bob, VE3YX, participated with Dark Skies EX with their local operation stationed at the Pembroke EOC.

#### **Submitted by the Stormont, Dundas & Glengarry ARES – GC Earle DePass, VE3IMP**

The Stormont, Dundas & Glengarry (SD&G)-ARES club and the Seaway Valley Amateur Radio Club (SVARC) continue to hold their monthly hybrid meetings featuring interesting Guest Speakers.

Coffee Klatches where members can socialize with each other are held on the 2nd and 4th Saturdays of each month, starting at 8:30 am, at Spinners Restaurant in Cornwall.

The SVARC held a Fox Hunt on October 15 near Alexandria Cornwall.

Repeater Checks: Our eight repeater systems continue to function very well.

The SVARC weekly Net is conducted on each Monday at 7:00PM (Local). The Net first starts on VE3SVC (147.180MHz.+). Checks are then made by switching the Net to the VE3PGC (UHF) repeater where an EchoLink check is performed. A check is also performed on VE3VSW, VA3FHA then DMR, Ch. 2. This process confirms the serviceability of nearby Seaway Valley Amateur Radio Club (SVARC) repeater systems at least once a week, should they be required by the RAC Auxiliary Communications Service (ACS). On average there are 20 total check-ins.

#### **South Glengarry ARES Projects:**

The VA3FHA repeater installed on August 29, 2022 at the Beaver Brook landfill site continues to function well.

#### **GCs (ECs) or Assistants reporting:**

VA3LP, VE3VL, VE3YX, VE3IMP & VE3IPC

#### **OBS reporting: VE3IQZ**

---

#### **QUEBEC / QUÉBEC:**

#### **SM: Sylvain Lamarre, VE2LAM lamarry@yahoo.com**

#### **September-October SM Report:**

On September 23, the Fédération des clubs radioamateurs du Québec (RAQI) was present at the annual Quebec Civil Security Association (ASCQ) Benevolents Gathering event ("Rendez-Vous des Bénévoles ASCQ 2023") in the town of Contrecoeur northeast of Montréal.

This event was a wide-scale simulation involving more than 250 people from eight benevolent associations. One of these was our Amateur Radio community, represented by RAQI and four regional Amateur Radio clubs, with 50 Amateurs.

The role of involved Amateurs was to carry logistics information from the various scenes back and forth with the event's supervising team, spread over approximately 15 kilometres. The teams even had to deal with a real emergency situation – a heatstroke. This event proved to be a great opportunity to illustrate the importance of Amateur Radio and to show all that it can do and especially in times of emergency.

On October 11, 12 and 13, representatives of RAQI participated in the Government of Québec's Civil Security Conferences ("Colloque sur la Sécurité Civile") which was held in Québec City. The event brought together nearly 600 people working in fields related to prevention, preparedness, emergency measures, continuity of operations, and volunteering in civil security.



Quebec Amateurs participate at "Benevolent Gathering 2023" event / Radioamateurs du Québec à la journée des bénévoles de l'ASCQ.  
<https://www.quebec.ca/securite-situations-urgence/securite-civile/activites-formation/colloque-sc/presentations-2023>

The event provided a great opportunity for participants to make important contacts in key sectors of the Québec government as well as key contacts from many other organizations. There was a wide range of conferences to choose from based on actual emergency situations such as as forest fires, extreme heat and cyberattacks. "From theory to practice: Coordinating a disaster site in Quebec" provided an excellent overview from emergency planning to lessons learned.

This fall we continued our monthly emergency communications practices, but with an eye toward new ways to do it. Bands, modes, regions and links, will all be observed, analyzed and, in some cases, tested with on-the-air pilots. Stay tuned for more information.

#### Rapport SM septembre-octobre :

Le 23 septembre, la Fédération des clubs radioamateurs du Québec (RAQI) a été représentée au Rendez-vous annuel des Bénévoles de l'ASCQ (Association de sécurité civile du Québec) 2023, tenu dans la ville de Contrecoeur, au nord-est de Montréal.

Cet événement a revêtu la forme d'une simulation à grande échelle organisée avec la participation de plus de 250 membres de huit associations bénévoles. L'une d'entre elles était notre communauté de radio amateurs, représentée par le RAQI et quatre clubs régionaux de radio amateurs, soit 50 adhérents.

Le rôle des amateurs participants consistait à transmettre bilatéralement des données logistiques entre les divers sites en cause et l'équipe chargée de la gestion de l'événement, les distances à franchir étant d'environ 15 kilomètres. Les équipes ont même dû faire face à une véritable situation d'urgence – un coup de chaleur. Cet événement a offert une formidable occasion de démontrer

l'importance de la radio amateur et de donner une idée de tout ce qu'elle peut faire, en particulier en cas d'urgence.

Les 11, 12 et 13 octobre, des représentants du RAQI ont participé au Colloque sur la sécurité civile qui s'est tenu à Québec. Cet événement a rassemblé près de 600 personnes qui travaillent dans des domaines liés à la prévention, à la préparation, aux mesures d'urgence et à la continuité des opérations, et contribuent comme bénévoles à assurer la sécurité civile.

Cet événement a donné aux participants une excellente occasion d'établir d'importants contacts dans des secteurs essentiels dépendant des pouvoirs publics du Québec, ainsi que de solides relations avec de nombreuses autres instances. Ils n'ont eu que l'embarras du choix vu la vaste gamme de conférences qui leur étaient proposées sur des thèmes s'inspirant de véritables situations d'urgence telles que les incendies de forêt, les épisodes de chaleur extrême et les cyberattaques. « De la théorie à la pratique: la coordination d'un site de sinistre au Québec » a fourni un excellent aperçu des questions abordées, de la planification des mesures d'urgence aux leçons apprises.

Cet automne, nous avons poursuivi nos activités mensuelles pour nous entraîner à faire face aux situations d'urgence, en recherchant toutefois de nouvelles façons d'agir. Les bandes, les modes, les régions et les liens sont autant de thèmes qui retiendront notre attention, seront analysés et, dans certains cas, feront l'objet d'évaluations menées avec l'aide de pilotes branchés sur les ondes. Restez à l'écoute pour ne manquer aucune mise à jour.

*Sylvain Lamarre, VE2LAM  
 Mesures d'urgence RAQI*

#### NEW BRUNSWICK

**SM Jean-Paul Leblanc, VE9BK  
 medals2@gmail.com**

#### September-October SM Report:

I am continuing to organize the new New Brunswick Section and I'm looking for volunteers to fill the various positions. Please see my last TCA report for a list of positions and additional information.

In this report I'd like to highlight one of the Amateur Radio capabilities we have in New Brunswick: the International Repeater Group (IRG). The IRG is an organization of Radio Amateurs who oversee a system of linked repeaters in New Brunswick, which also reaches into Maine, Nova Scotia and Prince Edward Island.

Formed in 1974, the IRG has grown and established respect among Amateurs and served agencies throughout the coverage area. There are 30 repeaters in the system (as of June 2023), and they are all on government-approved sites with backup power. Most repeaters are linked full-time in zones, and zones can be linked to other zones or all at once. Linking zones is done with simple DTMF tones supplied to members.

The linking system is a digital microwave system using radio frequencies. It does not rely on internet or telephone links so it is a good backup system when those systems fail. Most major centres have access to more than one zone so there is some redundancy in case of equipment failure. In 2023, the IRG began its most recent update, adding new repeaters and other hardware, along with the phase-in of CTCSS (PL tones).

The IRG itself operates with member support from dues payments. Along with membership dues, the IRG get help with equipment replacement and maintenance from the Department of Public Safety,

Department of Transportation and Infrastructure, Emergency Measures Organization, Department of Health, and other served agencies. In return, those groups welcome help from Amateur Radio operators for emergency operations. The IRG Network of repeaters can be linked all at once so that province wide communications are available during emergencies.

The main objective of the IRG network is to provide emergency back up communications to NB EMO, CanWarn, Municipal EMO's, First Responders, Ground Search and Rescue teams, and hopefully in the near future, Amber Alert.

Every Thursday night there is a Province-wide EMCOMM Net and the system is also used for province -wide exercises. New Brunswick is extremely lucky to have the IRG Network in place and I want to single out all of the work being done by volunteers and technicians in keeping the IRG in tip top shape should the need arise for its use.

– 73, Jean-Paul Leblanc, VE9BK

## PRINCE EDWARD ISLAND

**SM Bill McMaster, VY2WM**  
bill@vy2wm.ca

### September-October SM Report:

The Prince Edward Island Amateur Radio community has had a very busy early autumn season.

The Charlottetown Amateur Radio club (CARC) has started delivering their fall Basic Radio Course. This is the third such course in the last 12 months and is being held again at the Canadian Red Cross, Charlottetown Headquarters building. The PEI Amateur community wishes to thank the Canadian Red Cross for their hospitality and generosity. Seventeen individuals are enrolled in this course which is expected to wrap up the middle of November.

As part of ongoing efforts to be better prepared for extreme weather events on the Island, the Charlottetown ARC prepared a set of Emergency Communications Protocols to be implemented when necessary. These were distributed to all club members via email as well as shared on the club Discord server and on their website (www.charlottetownarc.com). The Protocols were also passed on to the provincial EMO office for their information.

As it turned out it didn't take Mother Nature long to give us a chance to test out

## RAC FIELD ORGANIZATION REPORTS

### National Traffic System (NTS) Net Reports

Net (Manager)	Sessions	QNI	QTC
<b>September 2023:</b>			
APSN (VE6JY)	31	2344	17
Alberta ARES (VE6JG)	13	231	4
BCEN (VE7XLH)	27	145	10
BCYTN (VE7WJ)	30	439	23
CECA (VE7GBK)	4	97	7
MEPN (VE4JS)	30	650	0
MMWXN (VA4GD)	30	508	2
MRS (VE4HK)	8	258	0
MSMN (VE4AJ)	22	617	0
Saturday (VE4AJ)			0
<b>October 2023:</b>			
AARN (VE7GBO)	31	4088	0
APSN (VE6JY)	31	2821	9
Alberta ARES (VE6JG)	6	298	16
BCEN (VE7XLH)	30	154	12
BCYTN (VE7WJ)	31	424	39
CECA (VE7AKE)	5	109	9
MEPN (VE4JS)	31	876	2
MMWXN (VA4GD)	31	654	1
MRS (VE4HK)	9	285	0
MSMN (VE4AJ)	22	576	0
Saturday (VE4AJ)			0

those plans on the weekend of September 16, with the passing of post-tropical storm Lee through the region. As per the plan, a preparatory net was held on Friday evening, September 15, on the VE1CRA repeater to review the protocols and take an inventory of station capabilities and preparations for the storm. On Saturday September 16, morning and evening 2m nets were convened to check on the wellbeing of the radio community and to take any reports of damage. A third 2m net was held on the morning of Sunday September 17, 2023.

Fortunately Lee was not much more than a typical fall storm for PEI. As such it was decided to conclude the Emergency Communications Protocols for Lee at that time. It was a great real-world test of the new plan and with only a few minor tweaks for improvement the consensus was that the protocols met the needs of the community very well. Eighteen radio amateurs participated in the emergency nets.

A number of significant changes and improvements have been made on Island repeater systems by Amateurs like Ron, VE1A1C, and others. These include the move to implement 100 Hz Tone Encoding for most repeaters to eliminate signals not meant for the system to respond to. A new repeater installation in the Belfast area of PEI, when complete, should also provide excellent coverage across most of the eastern part of the Island. A new 210-C4 antenna has been

installed on a 100-foot tower in the North Winsloe area. We are waiting for the installation and connection of a VHF repeater there to add another system for use in central PEI. Another system has been returned to service in the Glen Valley area after being out of the air for several years.

The October meeting of the Charlottetown ARC featured a sale of club owned equipment that was deemed to be surplus to our needs. The sale was conducted as a blind auction and a number of new club members were able to purchase radio gear for reasonable prices and the clubs finances benefited as well.

On October 21, PEI held its first Amateur Radio fleamarket in several decades. It was held at the Sherwood Recreation Hall in Charlottetown. Although the weather wasn't the greatest, turnout was good and everyone had a great time exploring the vendor tables, socializing and enjoying donated chilli and rolls. Since this was the first such activity in a long time, it was decided to keep the fleamarket simple and low key so promotion was mainly to Amateurs.

Based on the success this fall, planning will soon start for another fleamarket, possibly in July, 2024. Advanced notice will be shared this time with the other radio clubs and communities in the Maritimes, in hopes of drawing in visitors from off Island.

– 73, Bill McMaster, VY2WM



# World Radiosport Team Championship 2022

Tom  
Haavisto,  
VE3CX |  
ve3cx@  
myrac.ca

In my last column I was very pleased to have Yuri Onipko, VE3DX, share with us the incredible journey to the World Radiosport Team Championship 2022, which was held in 2023.

I would like to congratulate Yuri Onipko, VE3DZ (on the left in the photo) and Yarik Oleynik, UW7LL, on winning!

They faced many obstacles in order to compete in WRTC, which makes their first place finish even more special. I would also like to congratulate all the competitors, judges, organizers and

volunteers for their efforts in hosting WRTC 2022. There were a lot of hiccups along the way including a pandemic which delayed the competition by one year. It was no small feat to have teams from around the world come together to compete in the Olympics of Amateur Radio!

In WRTC, the goal is to “level the playing field” for all competitors as much as possible by eliminating or reducing many of the variables that arise in building a station. Each team is equipped with the same antennas, masts, etc. A great deal of effort goes into ensuring each team has similar topography to the other stations. Each team has a unique call sign to help identify them to the world so they can be readily recognized as being a WRTC competitor, but it also masks their identity for the duration of the contest. To that end, the organizers arrange all the basic infrastructure for the competitors, and each team brings their own radios and



supporting gear. It then becomes a contest of what band to be on, where to point the antenna, what mode to be on, and so on. It becomes a true competition between competitors where operator skill becomes the most important aspect.

WRTC 2026 will be hosted in England and planning has already started. Which brought up an interesting problem, and an opportunity for us all to help. WRTC 2022 was hosted in Italy, and they were looking to wind down operations by the end of the year – 2023. They wanted to sell off their remaining inventory of masts, antennas, rotators, cables, etc.



These items are set up ahead of time for the competitors to use during WRTC. They were not having much luck selling them locally. A deal was struck to purchase the entire inventory of some 50 systems for an attractive price by the organizers of WRTC 2026. This works well for both WRTC 2022 and WRTC 2026.

It also created a problem. Fundraising has only started and there were no funds in place to complete the purchase. A small group put up the funds to make a down payment, with the balance due at the end of the year. At this early stage of the game, corporate sponsorships are not yet in place so they have turned to the contesting community for help.

If you wish to help out, you can go to <https://www.wrtc2026.org> and make a donation to help get things going. We all help make WRTC what it is, and this is one more opportunity to participate, and help ensure WRTC 2026 is a success.

## What Category Are You In?

One of the interesting things about contesting is that there are lots of different categories to you to choose from. You can operate with high power, low power or QRP. Some contests have categories based on what antennas you have – multi-element antennas or simple wire antennas.

The best part is you can choose what works for you – and you can choose a different category in each contest. Naturally, budget plays a huge part in any station and I have seen a few folks comment that they feel their budget is the main limiting factor when it comes to contesting. However, they still want to compete – just that they don't expect to take first place...

## So how do we have fun, knowing that we can't “win”?

There are a couple of options than you can try. The first is to compete against yourself. I have saved all my contest logs into a folder on my computer. That way, when Contest X rolls around, I can look at my results from last year. My goal is to do better than last year. I may choose a different category – high power instead of low power, for example. My simple goal is to improve on last year's score. Spend more time in the chair, spend more time calling CQ, or try something else that you think might help. Before the contest, spend a few minutes looking at the previous year's entries to get a feel for what went well, and areas you can improve upon.

What I also do at the end of a contest is to spend a few minutes, and write a note. It includes a description of the station including antennas, radios, amps, and so on. What went well? What are areas that could have been better? Is there a switch or a rotator that broke during the contest? It will need to be fixed at some point – just not at that moment. Any highlights?

By putting this all into a file, you can then look at it next year, and also use that to help improve your contesting efforts.

# Contest Calendar: January, February and Early March

SARTG New Year RTTY Contest	0800Z, Jan 1	1100Z, Jan 1	<a href="http://www.sartg.com/contest/nyrules.htm">http://www.sartg.com/contest/nyrules.htm</a>
ARRL RTTY Roundup	1800Z, Jan 6	2400Z, Jan 7	<a href="http://www.arrl.org/rtty-roundup">http://www.arrl.org/rtty-roundup</a>
North American QSO Party, CW	1800Z, Jan 13	0600Z, Jan 14	<a href="https://www.ncjweb.com/NAQP-Rules.pdf">https://www.ncjweb.com/NAQP-Rules.pdf</a>
Hungarian DX Contest	1200Z, Jan 20	1200Z, Jan 21	<a href="http://ha-dx.com/en/contest-rules">http://ha-dx.com/en/contest-rules</a>
ARRL January VHF Contest	1900Z, Jan 20	0359Z, Jan 22	<a href="http://www.arrl.org/january-vhf">http://www.arrl.org/january-vhf</a>
NA QSO Party, SSB	1800Z, Jan 20	0600Z, Jan 21	<a href="https://www.ncjweb.com/NAQP-Rules.pdf">https://www.ncjweb.com/NAQP-Rules.pdf</a>
BARTG RTTY Sprint	1200Z, Jan 27	1200Z, Jan 28	<a href="http://bartg.org.uk/wp/bartg-sprint-contest/">http://bartg.org.uk/wp/bartg-sprint-contest/</a>
CQ 160-Meter Contest CW	2200Z, Jan 26	2159Z, Jan 28	<a href="http://www.cq160.com/rules.htm">http://www.cq160.com/rules.htm</a>
REF Contest CW	0600Z, Jan 27	1800Z, Jan 28	<a href="https://concours.r-e-f.org/reglements/actuels/reg_cdfhfdx.pdf">https://concours.r-e-f.org/reglements/actuels/reg_cdfhfdx.pdf</a>
UBA DX Contest SSB	1300Z, Jan 27	1300Z, Jan 28	<a href="https://www.uba.be/en/hf/contest-rules/uba-dx-contest">https://www.uba.be/en/hf/contest-rules/uba-dx-contest</a>
Winter Field Day	1700Z, Jan 27	1700Z, Jan 28	<a href="https://www.winterfeldday.com/">https://www.winterfeldday.com/</a>
Vermont QSO Party	0000Z, Feb 3	2400Z, Feb 4	<a href="http://www.ranv.org/vtqso.html">http://www.ranv.org/vtqso.html</a>
10-10 Int. Winter Contest SSB	0001Z, Feb 3	2359Z, Feb 4	<a href="http://www.ten-ten.org/index.php/activity/2013-07-22-20-26-48/qso-party-rules">http://www.ten-ten.org/index.php/activity/2013-07-22-20-26-48/qso-party-rules</a>
Mexico Int. Contest RTTY	1200Z, Feb 3	2359Z, Feb 4	<a href="http://www.rtty.f mre.mx/">http://www.rtty.f mre.mx/</a>
Minnesota QSO Party	1400Z, Feb 3	2400Z, Feb 3	<a href="https://www.w0aa.org/mnqp-rules/">https://www.w0aa.org/mnqp-rules/</a>
British Columbia QSO Party	1600Z, Feb 3	2400Z, Feb 4	<a href="http://www.orcadxcc.org/bcqp_rules.html">http://www.orcadxcc.org/bcqp_rules.html</a>
North American Sprint CW	0000Z, Feb 4	0359Z, Feb 4	<a href="https://ncjweb.com/Sprint-Rules.pdf">https://ncjweb.com/Sprint-Rules.pdf</a>
CQ WW WPX Contest RTTY	0000Z, Feb 10	2400Z, Feb 11	<a href="http://www.cqwpwxrtty.com/rules.htm">http://www.cqwpwxrtty.com/rules.htm</a>
Dutch PACC Contest	1200Z, Feb 10	1200Z, Feb 11	<a href="http://pacc.veron.nl/">http://pacc.veron.nl/</a>
ARRL Inter. DX Contest CW	0000Z, Feb 17	2400Z, Feb 18	<a href="http://www.arrl.org/arrl-dx">http://www.arrl.org/arrl-dx</a>
CQ 160-Meter Contest SSB	2200Z, Feb 23	2159Z, Feb 25	<a href="http://www.cq160.com/rules.htm">http://www.cq160.com/rules.htm</a>
REF Contest SSB	0600Z, Feb 24	1800Z, Feb 25	<a href="https://concours.r-e-f.org/reglements/actuels/reg_cdfhfdx.pdf">https://concours.r-e-f.org/reglements/actuels/reg_cdfhfdx.pdf</a>
South Carolina QSO Party	1500Z, Feb 25	0159Z, Feb 26	<a href="https://scqso.com/">https://scqso.com/</a>
UBA DX Contest CW	1300Z, Feb 24	1300Z, Feb 25	<a href="https://www.uba.be/en/hf/contest-rules/uba-dx-contest">https://www.uba.be/en/hf/contest-rules/uba-dx-contest</a>
North American QSO Party RTTY	1800Z, Feb 24	0600Z, Feb 25	<a href="https://www.ncjweb.com/NAQP-Rules.pdf">https://www.ncjweb.com/NAQP-Rules.pdf</a>
North Carolina QSO Party	1500Z, Feb 25	0100Z, Feb 26	<a href="http://ncqsoparty.org/rules/">http://ncqsoparty.org/rules/</a>
ARRL Int. DX Contest SSB	0000Z, Mar 2	2400Z, Mar 3	<a href="http://www.arrl.org/arrl-dx">http://www.arrl.org/arrl-dx</a>
RSGB Commonwealth (BERU) Contest	1000Z, Mar 9	1000Z, Mar 10	<a href="https://www.rsgbcc.org/hf/rules/2023/rcwc.shtml">https://www.rsgbcc.org/hf/rules/2023/rcwc.shtml</a>

**Note:** In the above chart an \* indicates Local Time. The "Contest Calendar" is presented as a guide only. RAC and TCA do not necessarily endorse or support any of the contests or the accuracy of the information. Bands: The 30, 17 and 12m bands are never used in any contest.

Please keep in mind this note is for you and not anyone else. Just that: you need to be able to read it next year and figure out what you are saying. You can also include some of these comments when you post your score to 3830 at: [www.3830scores.com](http://www.3830scores.com)

Speaking of 3830, you should spend some time reading the comments from other testers. See how the contest worked from their perspective, and compare scores. It offers an interesting insight into what worked well for someone else, and what issues they ran into during the contest. Before the contest, you can also look at the previous year's contest on 3830 for some extra insight.

I saw a comment a while back that bad conditions are actually good for folks who want to do well. How so? Some folks look at bad conditions and give up. They figure that slugging it out to make 5 to 10 QSOs an hour is too much

effort. Consider this: if you are making a handful of QSOs per hour and someone else is making zero QSOs per hour (since they threw in the towel), who will do better at the end? Clearly, the guy who kept going.

Last, but not least, the Real Time Scoreboard is helping to keep things interesting. This way, you can see in somewhat delayed real-time how other stations are doing – during the contest. Are you ahead of your competition or trailing behind? This can serve as an excellent motivator to help keep you going when things get slow.

As always, contesting is more than competition – it's about having fun. You are on the air, making contacts and enjoying your hobby with your friends. Hopefully, these tips will help make it even more fun!

Hope to see you on the bands. – Tom, VE3CX

**ARRL RTTY ROUNDUP – January 2023**

Call	QSOs	Mult	SEC	Category	Score
VE7SCC	1,415	111	BC	M2	154,068
VE6WQ	1,267	108	AB	SO HP(U)	134,460
VE7LWW	1,390	95	BC	SO HP(U)	129,390
VE3MGY	1,033	112	ONS	SO LP(U)	112,560
VA3DF	947	117	ONS	SO HP(U)	108,927
VA3LR	950	115	ONS	SO HP(U)	108,445
VE5CPU	887	87	SK	SO HP	76,125
VE5SF	854	84	SK	SO LP	71,064
VA7KO	722	97	BC	SO LP(U)	69,064
VE2BVV	637	106	QC	SO LP	67,098
VA7ST	771	80	BC	SO LP	60,960
VA7MAY	719	81	BC	MOST HP	56,538
VE3GYL	534	99	ONS	SO HP	51,480
VE5KS	657	78	SK	SO LP	50,934
VE7SZ	557	92	BC	SO HP(U)	50,784
VY2LI	539	91	PE	SO LP	48,594
VE3TW	607	81	GH	SO HP	48,519
VA3SB	577	85	ONE	SO HP	48,365
VE2GSO	621	77	QC	SO HP	47,432
VE2CSM	497	92	QC	SO HP(U)	45,448
VA2QR	528	86	QC	SO HP(U)	44,376
VA6RCN	560	74	AB	SO LP	41,292
VE2NMB	477	81	QC	SO LP(U)	37,746
VE3TM	397	94	ONE	SO LP	36,848
VE3FH	413	82	ONS	SO LP	33,784
VA1XH	377	89	MAR	SO LP	32,663
VE1LD	400	77	MAR	SO LP	30,800
VE3NFN	387	80	GH	SO LP	29,840
VA3LML	402	73	ONS	MOST LP	28,908
VE3PJ	357	79	ONE	SO LP	27,887
VE2OWL	289	85	QC	SO LP	24,480
VE3BR	281	73	GH	SO HP	20,221
VA2CZ	270	71	QC	SO HP(U)	18,247
VA7RY	305	57	BC	SO LP(U)	17,214
VA3WW	279	63	ONE	SO HP	16,317
VA3IK	224	73	ONE	SO HP	16,279
VE1QY	204	77	MAR	SO LP	15,246
VE3ZDR	210	66	ONN	SO LP	13,596
VA2SIB	234	57	QC	SO LP(U)	13,224
VA3EON	198	65	GH	SO LP	12,415
VE4/K0MKL	211	56	MB	SO LP	11,816
VE2ZWA	197	60	QC	SO HP(U)	11,640
VE3GTM	186	62	ONE	SO LP	11,346
VA2VT	196	56	QC	SO LP	10,808
VA2CST	179	56	QC	SO HP	9,968
VE7HS	189	51	BC	SO LP(U)	9,435
VE3NZ	164	60	ONS	SO QRP(U)	9,420
VE3EUS	152	60	ONE	SO LP	9,000
VE3FZ	145	61	ONE	SO LP(U)	8,601
VE3EP	143	47	ONE	SO LP(U)	6,533
VY2DP	136	47	PE	SO LP	6,204
VE6TK	112	53	AB	SO HP	5,883
VE2QV	111	52	QC	SO LP	5,772
VA3FN	123	45	ONS	SO LP	5,490
VA7ZM	126	42	BC	SO LP	5,208
VE3EY	119	44	GH	SO LP(U)	5,148
VE7AX	86	47	BC	SO LP(U)	3,948
VO2AC	101	34	NL	SO HP(U)	3,366
VA7EET	71	36	BC	SO LP(U)	2,412
VE6SYD	73	33	AB	SO LP	2,409
VE7IO	69	34	BC	SO LP(U)	2,244
VE3SST	49	29	ONE	SO LP	1,421
VA3PC	49	27	ONS	SO LP	1,296
VE7BGP	39	23	BC	SO LP	897
VA3JHQ	37	22	GH	SO LP(U)	770
VE2EZD	31	20	QC	SO HP	620
VA4JP	15	14	MB	SO LP	210
VE3JZT	10	9	ONS	SO QRP	81
VE7BLW	8	8	BC	SO HP	56
VE7KAJ	3	3	BC	SO LP(U)	9
VE7AB	2	2	BC	SO LP	4

**NAQP WINTER, CW – January 2023**

Call	Category	QSO	Mult	QTH	Score
VA2WA	M2	1989	338	QC	672,282
VE3EJ	SO(A)	1409	307	ON	432,563
VE3DZ	SO	1353	295	ON	399,135
VE3JM	SO	1368	247	ON	337,896
VE3MGY	SO(A)	1071	287	ON	307,377
VE5SF	SO(A)	1051	252	SK	264,852
VE3VN	SO	1108	237	ON	262,596
VE6TL	SO	897	212	AB	190,164
VA7ST	SO	882	205	BC	180,810

VE5UO	SO(A)	864	207	SK	178,848
VA7DX	SO(A)	702	235	BC	164,970
VE3YT	SO	790	202	ON	159,580
VE3NNT	SO(A)	820	182	ON	149,240
VE3GFN	SO(A)	591	249	ON	147,159
VE3EY	SO	718	200	ON	143,600
VE7KW	SO(A)	681	200	BC	136,200
VA1MM	SO	697	187	NS	130,339
VE3CX	SO	568	210	ON	119,280
VE3TM	SO	628	188	ON	118,064
VE4VT	SO(A)	453	255	MB	115,515
VE9XX	SO(A)	578	197	NB	113,866
VE2FK	SO(A)	583	180	QC	104,940
VE3MV	SO(A)	505	198	ON	99,990
VA3EC	SO(A)	500	195	ON	97,500
VE7ZO	SO(A)	533	145	BC	77,285
VE5KS	SO(A)	393	190	SK	74,670
VE3MA	SO	458	146	ON	66,868
VE5GC	SO	469	137	SK	64,253
VE9VIC	SO(A)	353	178	NB	62,834
VE3VY	SO(A)	386	161	ON	62,146
VE3KP	SO	394	152	ON	59,888
VA3WB	SO	369	154	ON	56,826
VE3KOT	SO	377	140	ON	52,780
VE9HF	SO	364	134	NB	48,776
VE4GV	SO(A)	339	137	MB	46,443
VE3AQ	SO	345	127	ON	43,815
VY1CO	SO	367	97	YT	35,599
VA3FN	SO	253	122	ON	30,866
VY2LI	SO	275	104	PE	28,600
VE3SIF	SO QRP	248	115	ON	28,520
VE3FH	SO	250	98	ON	24,500
VE7CV	SO	217	106	BC	23,002
VE3FP	SO(A)	203	100	ON	20,300
VE3PJ	SO(A)	182	107	ON	19,474
VE3KTB	SO(A)	193	99	ON	19,107
VE3ZY	SO	218	84	ON	18,312
VA3TMV	SO(A)	188	94	ON	17,672
VE3TW	SO	176	100	ON	17,600
VE3JZT	SO(A)	171	98	ON	16,758
VA2CZ	SO(A)	163	99	QC	16,137
VA4JP	SO	179	80	MB	14,320
VA3ROC	SO(A)	142	83	ON	11,786
VE2ZAZ	SO QRP	158	74	QC	11,692
VA3IJK	SO	147	76	ON	11,172
VE3SSR	SO(A)	135	63	ON	8,505
VE7IO	SO	115	67	BC	7,705
VE7NI	SO QRP	117	63	BC	7,371
VA6RCN (VE3RCN)	SO	108	66	AB	7,128
VA7MM	SO	94	69	BC	6,486
VY2DP	SO	96	59	PE	5,664
VA3IK	SO(A)	113	44	ON	4,972
VE3BXG	SO	92	53	ON	4,876
VE3FZ	SO(A)	79	61	ON	4,819
VA6BGE	SO	89	53	AB	4,717
VA2UR	SO(A)	79	53	QC	4,187
VE3VIG	SO	84	44	ON	3,696
VE3MM	SO	108	28	ON	3,024
VE3DQN	SO QRP	62	44	ON	2,728
VE3QN	SO	47	39	ON	1,833
VE3PQ	SO	53	32	ON	1,696
VA7ZM	SO	49	33	BC	1,617
VE3SST	SO	49	31	ON	1,519
VE3HZ	SO(A)	44	34	ON	1,496
VE3MDX	SO	46	27	ON	1,242
VE3HG	SO	49	23	ON	1,127
VE3EP	SO	38	28	ON	1,064
VE3XD	SO(A)	46	23	ON	1,058
VE7AB	SO	35	27	BC	945
VA3DKL	SO	36	26	ON	936
VE2VAB	SO	33	27	QC	891
VE9AA	SO	42	16	NB	672
VA3OOL	SO	27	24	ON	648
VE7ARN	SO	28	23	BC	644
VE7BLW	SO(A)	27	18	BC	486
VE2ZT	SO	21	17	QC	357
VE2OXP	SO	20	17	QC	340
VE3GMZ	SO QRP(A)	28	12	ON	336
VA6TI	SO(A)	21	15	AB	315
VA3IIF	SO QRP	15	13	ON	195
VE3EDX	SO	12	6	ON	72
VE7BGP	SO	6	5	BC	30
VE3OU	SO(A)	4	4	ON	16
VA2YZX	SO	3	3	QC	9

Checklog: VA7GI

**NAQP WINTER, SSB – January 2023**

Call	Category	QSOs	Mult	QTH	Score
VE3PJ	SO(A)	1000	217	ON	217,000
VE5SF	SO(A)	731	204	SK	149,124
VE2JFM (VE2JFM VA2CZ VA2JHE)					
	M2	602	169	QC	101,738
VA6HEM	SO	631	124	AB	78,244
VE3YT	SO(A)	502	148	ON	74,296
VA3IDD	SO(A)	397	154	ON	61,138
VY2LI	SO	473	126	PE	59,598
VE3TW	SO(A)	303	159	ON	48,177
VE3VY	SO(A)	329	133	ON	43,757
VE5DLC	SO	425	102	SK	43,350
VE7ZO	SO(A)	339	120	BC	40,680
VA3GKO	SO	349	113	ON	39,437
VE3DZ	SO	328	117	ON	38,376
VE3KTB	SO(A)	248	131	ON	32,488
VE3HZ	SO(A)	251	122	ON	30,622
VA6BGE	SO	248	98	AB	24,304
VE4WSC (VE4DL)	SO(A)	233	103	MB	23,999
VE3FZ	SO(A)	206	108	ON	22,248
VA3OOL	SO(A)	196	94	ON	18,424
VE1RPX	SO	235	77	NS	18,095
VA3CBU	SO	231	64	ON	14,784
VE3GJP	SO	178	74	ON	13,172
VE3RGO	SO(A)	154	83	ON	12,782
VE3IDT	SO	141	89	ON	12,549
VA4JP	SO	152	80	MB	12,160
VA3PC	SO(A)	131	82	ON	10,742
VY1CO	SO	155	66	YT	10,230
VA6TVA	SO	117	70	AB	8,190
VE3RVZ	SO	111	68	ON	7,548
VE7KPM	SO	100	73	BC	7,300
VA6RCN (VE3RCN)	SO	107	63	AB	6,741
VA3IJK	SO	116	57	ON	6,612
VE7CV	SO	97	59	BC	5,723
VA7EGZ	SO	86	63	BC	5,418
VE3TM	SO	98	54	ON	5,292
VE2IAA	SO	100	52	QC	5,200
VY2GF	SO(A)	96	51	PE	4,896
VE2HEW	SO(A)	76	46	QC	3,496
VE3KP	SO	68	46	ON	3,128
VE9RLW	SO	63	48	NB	3,024
VE6LQ	SO	67	42	AB	2,814
VE9WRS	SO	60	41	NB	2,460
VE3VSM	SO	68	31	ON	2,108
VA3TMV	SO(A)	54	38	ON	2,052
VE5WD	SO	48	42	SK	2,016
VA1XH	SO	55	36	NS	1,980
VE2QY	SO	48	36	QC	1,728
VA2KD	SO	44	38	QC	1,672
VA7XU	SO	56	27	BC	1,512
VE3PYJ	SO	61	23	ON	1,403
VE3WG	SO(A)	65	21	ON	1,365
VA7USD	SO(A)	44	27	BC	1,188
VE3RAC/M	SO	44	26	ON	1,144
VE2KLW	SO	47	24	QC	1,128
VE3BK	SO(A)	38	25	ON	950
VA6AGR	SO	35	27	AB	945
VA3EEB	SO	36	26	ON	936
VE3RHD	SO QRP	42	22	ON	924
VE3JZT	SO(A)	38	23	ON	874
VE7RSV	SO	29	24	BC	696
VY2DP	SO	30	19	PE	570
VE7BGP	SO	27	21	BC	567
VE2RRE	SO	17	14	QC	238
VE3EPS	SO	13	13	ON	169
VE7BLW	SO(A)	13	8	BC	104
VA3CBN	SO	7	7	ON	49
VA3WPS	SO(A)	5	5	ON	25
VE9RA	SO(A)	2	1	NB	2
VA3ERW	SO QRP	1	1	ON	1
VA3PNL	SO	1	1	ON	1

Checklog: VE5MX

**CQ 160 CONTEST, CW – January 2023**

Call	QSOs	Category	Countries	W/VE Multiplier	Score
VO2AC (VO2AC VE3KG)	1,338	MO	66	54	1,126,800
VE3EJ	1,385	SO HP(A)	60	58	974,208
VA2WA	1,213	SO HP(A)	60	58	863,052
VE3JM	1,194	SO HP	59	58	823,914
VE3DZ	1,134	SO HP	58	58	738,108
VE3AT	1,101	SO HP	49	58	668,322
VE3VN	746	SO HP(A)	52	56	454,464
VE2OJ (VE3AV VE3OP VE3ZY VE3ICV)					
	875	MO	37	58	437,285
VE9HF	672	SO HP(A)	48	53	404,808
VE3MGY	876	SO LP	28	58	378,314
VE3NZ	765	SO HP(A)	18	56	279,868

VA1RST	450	SO HP(A)	46	50	262,656
VY2WW (K4IQ)	525	SO HP	42	41	261,699
VO1HP	406	SO HP(A)	48	40	250,096
VA3AR	524	SO HP	15	54	178,434
VE6BBP	551	SO HP	9	56	172,250
VE3KP	406	SO HP	16	53	141,657
VA2EW	358	SO HP(A)	23	46	136,137
VE3XL	477	SO LP	11	47	134,792
VA2AM	184	SO HP(A)	46	46	111,872
VE3CT	345	SO HP(A)	13	50	107,604
VE3MM	365	SO LP	11	47	103,820
VE3UZ	402	SO LP	4	43	91,368
VE3PN	258	SO LP	16	44	78,540
VE6WQ	264	SO HP(A)	6	51	72,504
VE3VY	317	SO LP(A)	5	43	72,432
VA2UR	162	SO HP(A)	29	42	70,361
VE9ML (VE9ML VE9BK)	243	MO	15	40	67,320
VE3YT	256	SO HP	8	45	65,879
VE3WG	273	SO LP	3	46	64,582
VE4GV	228	SO HP(A)	5	49	59,616
VE3MA	283	SO LP(A)		44	58,300
VE3TW	278	SO HP(A)	1	43	58,080
VE3ADQ	246	SO LP	2	47	57,575
VA3EC	275	SO LP	2	41	55,900
VA7MM	215	SO HP	5	46	53,346
VE3BR	202	SO HP	4	40	43,252
VE3DS	192	SO LP	3	44	42,911
VE2OWL	207	SO LP	2	38	39,400
VA3FN	205	SO LP	1	40	39,319
VE9VIC	120	SO LP	11	26	23,976
VA3WB	139	SO LP		28	18,704
VA3TMV	111	SO LP(A)	1	31	16,960
VA7KK	100	SO HP(A)	2	33	16,870
VE7JKZ	99	SO HP	3	30	15,576
VE5SF	85	SO LP	37	37	14,837
VA3OKG	69	SO LP	3	40	14,620
VA2CZ	89	SO LP(A)	1	30	13,020
VA3EON	97	SO LP		27	12,366
VE2HLS	78	SO LP(A)	2	29	11,005
VA6RCN (VE3RCN)	62	SO LP	1	28	7,917
VA1MM	68	SO LP		22	6,820
VE3JZT	54	SO LP		26	6,474
VE5CPU	34	SO LP		23	3,703
VE2OXP	26	SO LP		19	2,128
VE3QN	22	SO LP		17	1,717
VE7IO	20	SO HP(A)		13	1,222
VA2EBI	25	SO HP(A)		11	1,177
VO2NS	22	SO HP(A)		12	960
VE3KTB	15	SO LP		12	792
VA7GI	9	SO LP		6	270
VO1NA	10	SO LP(A)		7	203
VA7ZM	6	SO LP		5	135
VE7AB	6	SO LP		4	96
VA7ST	4	SO LP		3	42

**BARTG RTTY, SPRINT – January 2023**

Call	QSO	Mult	Continents	Category	Score
VE2BVV	344	56	6	SOAB LP	115,584
VE5MX	223	53	5	SOAB HP	59,095
VA2CZ	296	54	3	SOAB LP	47,952
VA7ST	189	37	4	SOAB LP	27,972
VE1QY	116	44	3	SOAB LP	15,312
VE2FK	168	40	2	SOE	13,440
VA3IK	120	34	3	SOAB HP	12,240
VA7ZM	69	25	4	SOAB LP	6,900
VA1XH	57	31	3	SOAB LP	5,301
VE5CPU	52	15	3	SOAB HP	2,340
VA2SIB	37	14	2	SOAB LP	1,036
VA6RCN (VE3RCN)	27	12	2	SOAB LP	648

**NAQP WINTER, RTTY – February 2023**

Call	Category	QSOs	Mult	QTH	Score
VA7ST	SOAB	668	168	BC	112,224
VE5SF	SOAB	545	147	SK	80,115
VE5KS	SOAB(A)	495	153	SK	75,735
VA2CZ	SOAB(A)	404	169	QC	68,276
VE2BVV	SOAB	480	131	QC	62,880
VE2FK	SOAB(A)	447	136	QC	60,792
VA7MAY	SOAB	384	149	BC	57,216
VE2CSM	SOAB(A)	347	144	QC	49,968
VE7WO	SOAB	358	135	BC	48,330
VA6RCN(VE3RCN)	SOAB	322	130	AB	41,860
VE2HEW	SOAB(A)	357	113	QC	40,341
VY2LI	SOAB	320	110	PE	35,200
VE3GYL	SOAB	271	115	ON	31,165
VE5CPU	SOAB	310	97	SK	30,070
VA3ROC	SOAB(A)	256	114	ON	29,184
VE3FH	SOAB	251	111	ON	27,861
VA3OOG	SOAB(A)	227	107	ON	24,289

VA1CHP	SOAB(A)	279	83	NS	23,157
VE3NFN	SOAB	198	107	ON	21,186
VE3KTB	SOAB	194	87	ON	16,878
VE3CWU	SOAB	228	74	ON	16,872
VE3TW	SOAB	189	83	ON	15,687
VE3TM	SOAB	195	79	ON	15,405
VE3VID	SOAB	187	82	ON	15,334
VA3PC	SOAB(A)	160	83	ON	13,280
VA1XH	SOAB	154	85	NS	13,090
VE2PI	SOAB(A)	142	80	QC	11,360
KØMKL/VE4	SOAB	135	69	MB	9,315
VA7XH	SOAB	131	66	BC	8,646
VA3IK	SOAB	127	65	ON	8,255
VA7ZM	SOAB	105	60	BC	6,300
VE3VSM	SOAB	98	55	ON	5,390
VE5UO	SOAB(A)	104	51	SK	5,304
VE3EIB	SOAB(A)	95	55	ON	5,225
VE3HG	SOAB	76	42	ON	3,192
VA3FN	SOAB	74	39	ON	2,886
VE3WEJ	SOAB	53	39	ON	2,067
VE7BGP	SOAB	38	27	BC	1,026
VE6SYD	SOAB	32	29	AB	928
VE3JZT	SOAB QRP(A)	31	24	ON	744
VE3GMZ	SO QRP	31	21	ON	651
VA2QR	SOAB(A)	34	18	QC	612
VA3PAF	SOAB(A)	23	18	ON	414
VE7IO	SOAB	27	15	BC	405
VE9WH	SOAB(A)	18	15	NB	270
VA3EC	SOAB(A)	10	9	ON	90

Check Log: VE3NNT

**BC QSO PARTY – February 2023**

Call	CW QSO	SSB QSO	Mult	Category	Score
VA7RR	576	1,750	475	SOMIX HP	2,757,020
VE7UF	780	996	422	MOMIX HP	2,157,384
VA7ODX	752	893	426	MOMIX HP	2,042,244
VE7ACN	663	691	393	SOMIX HP	1,585,522
VE7SAR	637	378	318	MOMIX LP	1,050,752
VA7DX	403	500	287	SOMIX HP	749,744
VE7YBH	349	432	298	SOMIX HP	673,580
VE7CV	385	232	266	SOMIX LP	533,204
VA7GI	690		193	SOCW HP	532,740
VA7ST	587		193	SOCW HP	453,244
VE7AHT	505		172	SOCW HP	347,500
VA7EU	333	73	216	SOMIX LP	319,388
VA7TU		810	165	SOPH HP	267,360
VA7XU	345	44	178	SOMIX HP	261,364
VA7MM	360		165	SOCW HP	237,660
VE7ZO	229	233	170	SOMIX HP	235,020
VE7DX		551	190	SOPH HP	209,480
VE7KW	288	21	170	SOMIX HP	203,120
VE7XF	264	25	146	SOMIX HP	161,536
VE7CUP		549	143	SOPH LP	157,034
VE7VR	248	7	147	SOMIX HP	148,002
VE7IO	200		101	SOCW HP	80,860
VE7DB	162	57	106	MOMIX LP	80,832
VE7BGP	121	28	100	SOMIX LP	54,020
VE7JAR		258	90	SOPH LP	46,440
VE7UT		184	92	MOPH LP	33,896
VE3WG	72	43	83	SOMIX LP	31,202
VA7RN	116		66	SOCW LP	30,664
VE7IAD	53	44	79	SOMIX LP	23,720
VE7AV	135		43	SOCW LP	23,240
VE7JBQ		146	69	SOPH LP	20,168
VA7YJJ		128	78	SOPH LP	20,028
VE3CT	69		52	SOCW HP	14,432
VE7ARN	76		47	SOCW LP	14,308
VY1KX	46	30	57	SOMIX LP	14,048
VE7YAH		100	68	SOPH LP	13,600
VE4VT	47	21	57	SOMIX HP	13,210
VE5MX	39	12	43	SOMIX HP	7,860
VA7HC	3	50	42	SOMIX LP	4,704
VE7AB	36		32	SOCW LP	4,628
VA7QCE	39		29	SOCW LP	4,564
VE3ZY	38		29	SOCW LP	4,468
VA7USD		53	39	SOPH QRP	4,134
VE3KOT	29	6	30	SOMIX LP	3,920
VA4JP	25	12	31	SOMIX LP	3,904
VE3HZ	22	16	32	SOMIX LP	3,880
VE9XX	17	19	31	SOMIX HP	3,326
VA3GKO		44	35	SOPH LP	3,160
VA3FN	30		24	SOCW LP	2,940
VA7RPE	19	9	30	SOMIX LP	2,860
VE3TW	21	9	25	SOMIX HP	2,610
VE3SST	18	12	26	SOMIX HP	2,556
VA4HZ	24	6	22	SOMIX LP	2,456
VA7CTG		40	29	SOPH LP	2,320
VE5SF	16	10	26	SOMIX LP	2,224
VA7FC		33	33	SOPH QRP	2,218

VA6RCN	14	14	25	SOMIX LP	2,160
VE3VN	24		20	SOCW LP	1,960
VE2VAB	24		19	SOCW LP	1,864
VE3IDT		34	26	SOPH LP	1,828
VE3KP	22		17	SOCW HP	1,536
VA3RKM	15	4	18	SOMIX LP	1,264
VA3PC		26	22	SOPH LP	1,204
VE7JKZ	18		15	SOCW LP	1,080
VA3KRJ	17		15	SOCW LP	1,060
VA3EC	17		14	SOCW LP	992
VA7VF		26	19	SOPH LP	988
VA7EET		20	22	SOPH LP	920
VE3RGO		23	18	SOPH LP	868
VA3IDD		20	17	SOPH LP	740
VE7BLW	12	1	14	SOMIX LP	700
VA7KBM	10	1	16	SOMIX LP	672
VA7AV	13		12	SOCW LP	644
VE7KX		17	16	SOPH LP	544
VA7RYL		14	14	SOPH LP	412
VE9BEL	12		8	SOCW QRP	404
VE9RLW		15	12	SOPH LP	400
VE1CHL		12	9	SOPH LP	236
VE6CA		10	10	SOPH HP	220
VE3KJQ	7		6	SOCW QRP	188
VA3DKL	7		6	SOCW LP	188
VY1XY		10	8	SOPH HP	180
VE6LQ		10	8	SOPH LP	180
VE1TWM		9	9	SOPH LP	162
VA7VX		6	7	SOPH LP	104
VE3DQN	4		4	SOCW QRP	84
VA3IJK	4		4	SOCW LP	84
VE3JZT	4		3	SOCW LP	68
VE2GT		2	2	SOPH HP	8
VE7IBI		1	2	SOPH LP	4
VA3TTQ		1	1	SOPH QRP	2
VA7GAP		1	1	SOPH LP	2

**CQ 160 CONTEST, SSB – February 2023**

Call	QSOs	Category	Countries	W/VE Multiplier	Score
VE3MGY	605	SO LP	9	48	168,207
VA3AR	443	SO HP	1	41	89,460
VY2WW	262	SO HP	20	37	79,173
VE3PJ	333	SO LP(A)	2	40	67,746
VE3HJ	286	SO HP		40	54,280
VE3VY	198	SO LP(A)	2	36	36,670
VE3BR	195	SO HP	1	37	36,024
VE3CKO	165	SO HP	5	38	34,486
VA3AC	181	SO LP	1	33	29,036
VE6BBP	129	SO HP	3	35	23,104
VE3EJ	100	SO HP(A)	4	31	16,905
VE3WG	101	SO LP	1	27	13,860
VE3KMQ	90	SO LP	1	28	12,615
VE3LRL	98	SO LP		27	12,582
VA3GKO	95	SO LP		24	10,752
VE3NQM	75	SO LP		24	8,640
VE3TW	70	SO HP(A)		25	8,375
VE9ML	60	SO LP(A)	1	22	6,624
VE3MT	57	SO LP		24	6,408
VE3MM	60	SO LP		20	5,460
VA2KD	47	SO LP		22	4,906
VE6TL	49	SO HP	1	20	4,620
VA7MM	53	SO HP	1	17	4,320
VE6TN	50	SO LP	1	18	4,104
VE3VN	28	SO HP(A)	3	19	3,212
VE7DX	41	SO LP	1	16	3,162
VA3WW	33	SO HP(A)		20	3,120
VE9RLW	39	SO LP		16	2,928
VE3JZT	32	SO LP(A)		18	2,718
VA2LGO	36	SO LP		16	2,688
VA3EON	29	SO LP		15	2,175
VE3BFU	29	SO LP(A)		15	2,085
VA3RKM	28	SO LP		14	1,792
VA7EU	25	SO LP	1	10	1,265
VE6AO (VE6CCL)	22	SO HP(A)		13	1,040
VA7FC	20	SO LP		7	595
VA3FN	10	SO LP		9	450
VA6RCN (VE3RCN)	11	SO LP		5	185
VE2LJV	1	SO LP		1	5

**UBA DX CONTEST, CW – February 2023**

Call	QSOs	Mult	Points	Category	Score
VE3NNT	254	49	763	S010 HP	38,220
VA3TNM	134	81	447	SOAB HP	37,989
VA1MM	113	64	385	SOAB HP	26,048
VE2FK	82	40	298	SOAB HP	12,640
VE3MA	70	58	301	SOAB LP	19,836
VE3MM	22	19	85	SOAB LP	1,691
VA3FN	22	11	58	SOAB LP	660
VE2QV	6	9	39	SOAB LP	486

**MINNESOTA QSO PARTY – February 2023**

Call	QSO	Mult	Category	Score
VE5KS	99	48	SOLP	9,504
VE3FP	81	43	SOCW	6,966
VE5MX	66	39	SOHP	5,148
VA3GKO	75	34	SOPH	5,100
VE2FK	65	32	SOCW	4,160
VE3OOU	67	31	SOPH	4,154
VA3PC	55	27	SOPH	2,970
VA6RCN	40	25	SOLP	2,000
VA3IDD	40	22	SOPH	1,760
VE3RGO	38	23	SOPH	1,748
VE3KP	33	24	SOCW	1,584
VA3IK	37	20	SOLP	1,480
VA4JP	28	18	SOLP	1,008
VE3HZ	28	17	SOPH	952
VE7NI	24	19	QRP	912
VE3KOT	22	17	SOLP	748
VA3FN	17	14	SOCW	476
VE2/F4HWJ	15	13	SOPH	390
VA7ODX (VA7BEC VA7KO)	14	10	MULTI-OP	280
VE2VAB (VE2CRO)	11	11	SOCW	242
VE3JZT	12	10	SOCW	240
VE3DQN	12	7	QRP	168
VE3PYJ	6	4	SOPH	48
VE9WRS	4	4	SOPH	32
VA3JK	3	3	SOLP	18
VE6LQ	3	3	SOPH	18
VA3TTQ	2	2	QRP	8
VE2GT	2	2	SOPH	8

**SOUTH CAROLINA QSO PARTY – February 2023**

Call	QSO	Category	Mult	Score
VE3RGO	56	SOPH LP	28	4,136
VE3HZ	45	SOMIX LP	27	3,430
VA3RKM	30	SOMIX LP	22	2,570
VA3PC	38	SOPH LP	24	2,074
VA3GKO	29	SOPH LP	21	1,968
VA3FN	29	SOCW LP	15	1,620
VE3PQ	25	SOCW LP	18	1,400
VA3IDD	25	SOPH LP	16	1,300
VE3SIF	28	SOCW QRP	14	1,284
VE9RLW	17	SOPH LP	13	1,192
VE7CV	20	SOMIX LP	14	1,060
VA7KO	18	SOCW LP	14	1,004
VA6RCN	9	SOMIX LP	8	894
VE3DQN	8	SOCW QRP	7	612
VE5GC	9	SOCW LP	6	608
VE2VAB	16	SOCW LP	11	602
VA7RN	8	SOCW HP	6	596
VY2LI	7	SOMIX LP	6	584
VA7BEC	4	SOPH LP	3	524
VA3PAF	10	SOMIX LP	10	450
VE3JZT	5	SOCW LP	5	300
VE9RA	5	SOPH LP	5	300
VA4JP	3	SOMIX QRP	3	268
VE2GT	3	SOPH HP	3	268
VA3JK	8	SOMIX LP	7	112
VE3KOT	5	SOCW LP	5	50
VA3PCJ	2	SOCW QRP	2	8

**CQ WW WPX CONTEST, RTTY – February 2023**

Call	QSO	PFX	Category	Score
CJ2X (VE2CSM VE2EBK VE2FK VE2NMB)	2,371	820	MO DIST	5,638,320
VE3MGY	1,266	550	SOAB LP(T)	2,020,150
VE7LWW	1,441	583	SOAB HP	2,015,431
VE2GSO	1,332	534	SOAB HP	1,978,470
VA7KO	1,306	572	SOAB HP	1,827,540
VA1XH	920	463	SOAB LP(C)	1,319,550
VE3KTb (VE3KTb VA3LML)	940	412	M1 HP	1,224,876
VE6BBP	938	478	SOAB HP	1,127,124
VA7MAY (VA7MAY VA7MM)	989	392	M1 HP	1,125,432
VE2BVV	854	461	SOAB LP(T)	1,117,464
VA3LR	769	456	SOAB HP	1,071,600
VE3CT	655	445	SOAB HP	967,430
VE3NZ	744	486	SO10 HP	946,242
VE3DZ	670	392	SOAB LP(C)	912,576
VE5KS	882	439	SOAB LP	908,730
VA7ST	936	374	SOAB HP	896,104
VE3PJ	670	399	SOAB LP	818,748
VA2QR	641	349	SOAB HP	669,033
VY2LI	595	369	SOAB LP(T)	643,536
VE6UM (VE6BMX)	587	370	SO10 HP	496,170
VA3SB	557	309	SOAB LP	451,140
VA6RCN (VE3RCN)	569	296	SOAB LP(T)	439,856
VE7DX	537	320	SO10 HP	388,160
VA4HZ	575	283	SOAB LP	355,165

VA3FF	434	272	SOAB LP(T)	353,872
VA3PC	379	318	SOAB LP	353,616
VA2CZ	451	328	SOAB HP	336,856
VA2CST	420	251	SOAB HP	328,810
VE2HEW	455	251	SOAB LP	320,276
VE2EZD	396	253	SOAB HP	292,721
VE3TW	375	223	SOAB HP	242,624
VE3EJ	330	250	SOAB HP	237,250
VE3TM	341	269	SO10 LP(T)	222,194
VE3EY	306	201	SOAB LP(T)	208,035
VE7HS	331	218	SOAB LP	168,296
VE5SF	298	204	SOAB LP	156,264
VA3EON	300	197	SOAB LP	153,463
*VE6TN	302	174	SOAB LP	136,068
VA2SIB	226	149	SOAB LP	102,065
VE3HG	222	153	SOAB LP	101,286
VE1ANU	193	158	SOAB LP	97,328
VE3MZD	220	182	SOAB HP	96,096
VE3GTM	200	153	SOAB LP	93,483
VE3CWU	237	177	SOAB LP	93,279
VE3SS	207	163	SOAB HP(T)	89,324
VE3EUS	205	172	SOAB LP	84,624
VA3OGG	199	142	SOAB LP	60,208
VA7ZM	187	133	SOAB LP	56,525
VE1QY	119	98	SOAB LP	45,276
VE2QV	133	103	SOAB LP	42,024
VA3WB	138	119	SOAB LP	40,222
VO1CH	117	112	SOAB HP	34,160
VE6FRD	103	89	SOAB LP	29,370
VE2OWL	106	96	SOAB LP	29,184
VY2DP	113	92	SOAB LP	27,140
VE3BFU	106	100	SO10 QRP	25,000
VA3IK	99	81	SOAB HP	23,652
VE6SPS	107	79	SOAB LP	21,804
VE3SST	99	75	SOAB HP	20,100
VE3HLS	75	66	SO40 LP	20,064
VA3JHQ	89	75	SOAB LP	18,225
VE6SYD	82	73	SOAB LP(R)	15,257
VA3FN	72	63	SOAB LP	15,120
VE7BGP	71	63	SOAB LP	10,080
*VE5VG	70	66	SOAB LP	9,966
VE6AO (VE6TC)	70	59	SO10 HP	9,027
VE7KAJ	68	62	SO10 LP	8,680
VE7IO	37	34	SOAB HP	4,590
VE7AF	46	43	SOAB LP	4,343
VA3WW	58	49	SO20 HP(C)	3,626
VE3FZ	37	34	SOAB LP	3,570
KOMKL/VE4	41	41	SO15 LP	3,403
VE3RUV	35	34	SOAB LP	3,162
VE3FR	29	24	SOAB LP	1,416
VE3JZT	20	19	SOAB QRP	798
VA7HZ	5	5	SOAB LP	50

Checklogs: VA3WEB VE3GMZ

\*Scores were received after the 5 day deadline and are not eligible for awards.

Rookie (R): licensed less than 3 years. |Classic(C): single op, no assistance, 1 radio, max 24 hours  
TB-Wires (T): tribander for 10-20m and single-element wire antennas for 40-80m

**DUTCH PACC CONTEST – February 2023**

Call	QSOs	Mult	Category	Score
VE9ML	107	49	SOAB CW HP(U)	5,194
VA3TNM	74	37	SOAB CW HP	2,627
VA1MM	66	30	SOAB CW HP	1,950
VE3NFN	55	30	SOAB MIX LP	1,470
VE3KP	44	29	SOAB CW HP	1,276
VE3VN	41	30	SOAB CW LP	1,230
VA3EC	36	23	SOAB CW LP	805
VE3RVZ	34	20	SOAB SSB LP	680
VA3GE	17	15	SOAB CW LP	255
VE7ZO	20	12	SOAB MIX HP	228
VE9OA	19	13	SOAB CW LP	208
VE9KK	12	10	SOAB MIX LP	80
VE9MO	11	8	SOAB SSB LP	80
VE9RLW	7	5	SOAB SSB LP	35
VA3RKM	3	3	SOAB CW LP	9
VA3FN	2	2	SOAB CW LP	4
VA6AGR	2	2	SOAB SSB LP	4

**MEXICO INT. CONTEST, RTTY – February 2023**

Call	Power	Score
VE3MZD	HP	47850
VA2QR	HP	34200
VA2CST	HP	26352
VE5CPU	HP	14670
VA3IK	HP	10044
VE2BVV	HP	73794
VY2LI	HP	46992
VE1QY	HP	17136
VA7ZM	HP	2190
VA6RCN	HP	1749

**NORTH AMERICAN SPRINT, CW – February 2022**

Call	QSO	Mult	Category	Score
VE3YT	230	41	SO LP	9,430
VE5SF	212	43	SO LP	9,116
VE5MX	88	36	SO	3,168
VE3KOT	67	29	SO LP	1,943
VA6RCN	37	19	SO LP	703
VO1BQ	2	2	SO	4

**ARRL INT. DX CONTEST, SSB – March 2023**

Call	QSOs	Mult	Category	Score
CF3A (VE3AT)	2,952	389	SOAB HP	3,416,976
VY2TT (K6LA)	3,273	332	SOAB HP	3,229,032
VA2CZ	1,571	314	SOAB HP(U)	1,464,810
VE6TN	919	301	SOAB LP	823,536
VE3GYL (VE3GYL VE3UZ)	1,065	250	MOST HP	793,500
VE3VN	882	273	SOAB QRP	719,901
VE3EY	716	267	SOAB HP(U)	571,113
VA2WA	1,549	111	SO10 HP(U)	512,820
VE3LRL	659	249	SOAB LP	483,309
VA3WW	630	258	SOAB HP(U)	482,202
VA2SJ	664	219	SOAB HP(U)	429,021
VE5SF	663	215	SOAB LP	419,895
VA2AM	485	267	SOAB HP(U)	382,077
VE3RGO	592	216	SOAB LP(U)	380,376
VA2UR	677	183	SOAB HP(U)	366,183
VA7OM	730	167	MOST HP	358,215
VA7BEC	575	204	SOAB LP(U)	348,840
VE6FI (VE6AQ)	491	229	SOAB HP(U)	333,195
VE2HIT	495	225	SOAB LP	332,775
VE7SAR (VA7JDJ VA7QD VA7VJ VA7XB VA7XH VE7KGG VE7LXB VE7SSD VE7SXM VE7TI)	572	195	MOST HP	325,260
VA3OOL	501	216	SOAB LP(U)	324,000
VE7ZO	526	195	SOAB HP(U)	304,200
VA3IDD	454	225	SOAB LP(U)	303,075
VO2AC	567	178	SOAB HP(U)	300,108
VO1KVT	996	98	SO15 HP(U)	290,766
VE3CT	310	309	SOAB HP(U)	285,516
VE3OJN	390	237	SOAB HP(U)	273,735
VE7ACN	513	169	SOAB HP(U)	259,077
VA7TU	523	168	SOAB HP(U)	254,520
VA3OKG	447	183	SOAB LP	243,756
VE6LQ	391	196	SOAB HP(U)	226,380
VE4SG	377	204	SOAB HP	223,992
VA3AR	814	92	SO15 HP	223,008
VE3ZZ	363	203	SOAB HP(U)	219,849
VE3HZ	401	183	SOAB LP(U)	215,757
VE5MX	755	95	SO10 HP(U)	214,605
VE2OV	371	197	SOAB HP(U)	212,169
VA3ZNQ	395	174	SOAB HP(U)	203,580
VE3TG	427	158	SOAB LP	202,398
VE3GJP	341	190	SOAB LP	192,090
VE5ZX	366	180	SOAB LP(U)	189,540
VE3RVZ	411	151	SOAB LP	184,824
VE2CSM	388	147	SOAB LP(U)	168,903
VE3NFN	368	165	SOAB LP	168,795
VE3DZ	626	88	SO10 HP	165,000
VA3TNM	314	173	SOAB HP(U)	160,371
VE6AO (VE6CCL VE6JCL VE6TC)	371	140	MOST HP	153,720
VE3FZ	260	192	SOAB LP(U)	149,184
VA3SB	355	139	SOAB HP	145,950
VE6BBP	219	219	SOAB HP(U)	143,883
VA3LUK	281	173	SOAB HP(U)	143,763
VA3GD	308	151	SOAB LP	138,618
VE3DZG	295	155	SOAB LP	134,850
VY2OM (VY2OL VY2OM)	330	142	MOST HP	131,208
VE3EPS	355	126	SOAB LP	130,788
VE2IAA	240	161	SOAB LP	114,954
VA3UG	289	131	SOAB LP(U)	112,398
VY2DS	280	154	SOAB HP	112,266
VA3IPG	420	88	SO10 LP(U)	107,448
VY2GF	303	110	SOAB LP(U)	98,340
VE3RRH	278	125	SOAB LP	97,500
VE3KTB	218	139	SOAB HP(U)	90,906
VE3TW	241	125	SOAB HP(U)	90,000
VE4WSC (VE4DL VE4GKM VE4PL VE45F)	227	130	MOST LP	85,410
VE3FAC	198	140	SOAB LP(U)	81,900
VE3KMQ	252	110	SOAB LP	81,510
VA3WU	165	144	SOAB LP(U)	70,848
VE4JBB	249	90	SOAB LP	66,420
VE3HG	206	107	SOAB LP(U)	65,805
VE6UM	326	64	SO10 HP	62,592
VE7IZ	213	100	SOAB LP(U)	62,400
VO1TX	204	104	SOAB LP	62,400
VE7HS	201	104	SOAB LP(U)	61,776
VE3KOT	193	106	SOAB LP	60,102
VE7WO	216	83	SOAB HP	53,784
VE7CV	172	103	SOAB LP(U)	52,221
VE3TM	245	71	SO10 LP	51,759
VE2HEW	169	102	SOAB LP(U)	51,714

VE3GKT	171	102	SOAB LP	50,490
VA6TVA	196	87	SOAB LP	50,373
VY2LI	276	61	SO10 LP	49,776
VE7DX	295	53	SO10 HP(U)	45,633
VA3DBT	161	90	SOAB LP	42,660
VO2MS	163	87	SOAB LP	42,282
VE3SVQ	147	94	SOAB LP	40,326
VA2QR	148	92	SOAB HP(U)	40,296
VE4IM	150	90	SOAB HP(U)	39,420
VO1TAP (VO1BYD VO1OP)	162	85	MOST HP	39,270
VE3BR	126	106	SOAB HP	39,114
VE3JZT	137	89	SOAB HP(U)	34,977
VE3NZ	210	57	SO10 QRP	34,713
VE3MGY	140	84	SOAB LP(U)	34,020
VA7XU	145	77	SOAB HP	32,109
VE3FH	168	64	SO15 LP	31,872
VE7VU	154	67	SOAB HP	30,150
VE7IAD	160	74	SOAB LP	29,970
VO1TH	133	77	SOAB LP	29,799
VA2KS	141	70	SOAB LP(U)	29,400
VA3YI	131	74	SOAB LP	28,416
VE6CLG	118	81	SOAB LP(U)	27,945
VA3CBU	131	75	SOAB LP	27,675
VE7CPU	144	63	SOAB LP	26,460
VA4BDK	115	81	SOAB LP	26,244
VA3QAK	100	86	SOAB LP	24,510
VA3NW	116	64	SOAB LP	22,080
VA2OT	93	78	SOAB LP(U)	21,528
VE3BFU	132	55	SO15 LP(U)	21,450
VE7RSV	126	53	SOAB LP	19,875
VA3OV	115	60	SOAB HP	19,800
VE3CW	98	65	SOAB QRP	18,915
VE3KP	96	61	SOAB HP	17,568
VA3CK	93	65	SOAB LP	17,355
VA7EGZ	101	57	SOAB LP	17,100
VA4ADM	95	61	SOAB LP(U)	16,836
VE7AHT	117	49	SOAB HP(U)	16,758
VE3EIB	89	61	SOAB LP(U)	15,555
VE3CA	102	52	SO10 LP	15,444
VA6AGR	88	56	SOAB LP	14,616
VE5CPU	98	52	SOAB HP	14,508
VE3FR	91	55	SOAB LP	14,190
VA3IK	90	52	SOAB HP(U)	14,040
VE3GRA	106	44	SO10 LP	12,804
VE3HLS	65	59	SOAB LP	11,328
VE6SYD	97	40	SOAB LP	11,280
VE7CKZ	74	46	SOAB LP(U)	10,074
VE3QEE	69	46	SOAB LP	9,246
VE6CSX	60	51	SOAB HP(U)	9,027
VA6RCN (VE3RCN)	66	44	SOAB LP	8,712
VE3LVW	60	49	SOAB LP(U)	8,673
VA6MA	90	33	SO10 LP	8,613
VE3JGO	62	48	SOAB LP	8,496
VO1CH	53	53	SO10 HP(U)	8,427
VA3EON	77	30	SO10 LP	6,660
VE3YT	69	32	SO10 HP(U)	6,624
VE3ETE	53	43	SOAB LP	6,579
VE2NDB	58	39	SOAB LP(U)	6,084
VA3KRT	56	34	SOAB LP(U)	5,610
VA7KL	52	38	SOAB HP	5,586
VA4JP	49	36	SO10 LP	5,292
VE3MZD	41	38	SOAB HP(U)	4,674
VE2RRR	46	34	SOAB LP	4,284
VE5DLC	44	31	SOAB LP	3,906
VE7BGP	46	28	SOAB LP	3,696
VE5WD	33	28	SOAB LP	2,772
VA7JC	42	23	SOAB HP(U)	2,622
VE7TI	33	27	SOAB LP(U)	2,430
VE3DLS	34	23	SO15 LP	2,277
VE4GKM	33	22	SOAB LP	2,112
VA3FN	31	22	SOAB LP	2,046
VE3RAC (VE3AC)	29	23	SO10 LP	1,932
VE7BLW	45	13	SOAB LP	1,677
VE3QN	31	19	SOAB LP	1,653
VE3OU	25	20	SOAB LP(U)	1,500
VA35XP	26	19	SOAB LP	1,311
VA7VX	24	14	SOAB LP	882
VA25IB	18	16	SOAB LP(U)	864
VA7LGN	22	13	SOAB LP	819
VE7FAA	20	13	SOAB LP	780
VE5GC	18	15	SO10 LP	675
VE2LJV	18	13	SOAB LP	546
VA7RYL	15	7	SOAB LP(U)	315
VE3NI	11	8	SO15 LP	264
VE6CA	8	7	SO20 HP	168
VE2KHC	9	7	SO10 LP(U)	168
VO1KGZ	8	7	SOAB LP	147
VE2GT	6	6	SOAB HP(U)	108
VE7BUI	5	5	SO10 LP	75
VA2VT	4	4	SO10 LP	48
VA7IR	4	4	SO20 QRP	12
VE5SR	2	2	SOAB LP	6

# Club Corner | Bits and Pieces



**Phillip Boucher, VE3BOC**  
 phillipjboucher@gmail.com  
 www.phillipjboucher.com

## The Hamilton ARC Hamfest: A Success

On Saturday, September 30, I attended my first Hamfest in a very long time when I went to the Hamilton Amateur Radio Club's Hamfest in Ancaster, Ontario.

I had a very good time and spent the morning and early afternoon slowly walking around and

looking at all the tables and the goodies that were on sale that laid upon them. I was not only fascinated by some of the older HF rigs that I saw, but I also found myself drooling over a couple of vintage handhelds (HTs) that brought back some youthful memories.

I stopped at the ICOM table and oogled all the new equipment that was on display, grabbing up the product brochures to read and fantasize with at home.

Perusing other tables, I saw all sorts of mobile and base antennas, handheld, mobile, and base VHF, UHF, Dual Band, and HF radios of all sorts, accessories, microphones, keyers, scanners, receivers, tubes, and anything else a little hobbyist's heart could want. Of course, I was fascinated by the new top of the line HF and mobile rigs, with bells and whistles galore. I wanted to buy up everything and outfit my shack with the latest and greatest gear.

In the club's newsletter, Hamilton ARC President Murray Thompson, VE3ZPV, wrote: "I am pleased to announce our successful Ancaster Hamfest 2023 that took place on September 30, 2023. The club enjoyed beautiful weather, and attendance was well over 275 through the gate. Plenty of Super Prize winners with ICOM Canada donating a VHF portable, Degen Designs, Radioworld, and Mario Tube Man with major awards. Congratulations to our 50/50 cash winner Pat Danby.

More important was the setup and take down crew for the event. Lastly, thanks to Barry Lisoweski, VE3ISX, for heading up the Hamfest. The club enjoyed some well deserved new revenue. Jess Sawadski, VA3JES, won the free membership for 2024."

I had my picture taken by Barry, VE3ISX. Thanks Barry! You know how many people there recognized me? None! Nobody. And I visited most of the tables at the venue and walked past a whole bunch of other hobbyists.

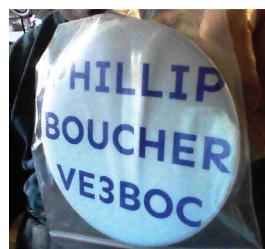

So, for the next Hamfest I go to I will be wearing my new huge button. Nobody will not know who I am then, he he.



**Phil Boucher, VE3BOC, enjoying his first hamfest in years thanks to the Hamilton Amateur Radio Club. Photo by Barry Lisoweski, VE3ISX.**



**ICOM Canada had booth at the Hamfest and also donated a VHF portable. Degen Designs, Radioworld and Mario Tube Man also provided major awards. Thank you Sponsors!**

It was a very exciting and wonderful day that I thoroughly enjoyed. I can't wait until next year to go again, and to hit other Hamfests in the area.

I also want to thank the Hamilton ARC for posting a link on their website's "About Us" page under this banner to the actual article in the TCA. It is very much appreciated. To read more about the Hamilton Amateur Radio Club see page 57 and visit their website at <https://hamiltonarc.com/>



**Spotlight on Hamilton ARC**  
 courtesy of RAC TCA Nov-Dec 2021  
 by Phillip VE3BOC  
 Click for two page article



Please send your club news, bits and pieces, tales and adventures, questions and comments to me at: [phillipjboucher@gmail.com](mailto:phillipjboucher@gmail.com)

# Celebrating HMCS Haida's 80th Anniversary

## Jerry Proc, VE3FAB

To celebrate Her Majesty's Canadian Ship (HMCS) Haida's 80th anniversary of service, a number of events were planned for the weekend of August 26 and 27. Haida is a National Historic Site administered by Parks Canada. The ship was commissioned on August 30, 1943.



Haida was dressed for the occasion. The firings of the 4-inch "A Gun" were followed by a sounding of the sirennet at 11 am, 1 pm and 2 pm on both days. Second World War re-enactors were onsite in period costume to provide firing demonstrations that brought HMCS Haida's military heritage to life. Guided tours were offered throughout the day and on each day.



Visitors were involved in activities aboard the ship and on the jetty, including interactive stations such as knot tying, signalling and heaving line demonstrations. These activity stations were run by volunteers from the Dundas Sea Cadets. One of the stations offered airbrush tattoos by Parks Canada staff. Complimentary treats and refreshments were available each day. A free souvenir patch was made available for guests while supplies lasted. On the Mess Deck, visitors could check out "Looking Back", a special photo exhibit that showcased the last 80 years. These photo contributions honoured the ship's naval history and Haida's contribution to Hamilton's waterfront.

Rick Bialachowski, VA3WWV, Chair of the Friends of HMCS Haida's 80th Anniversary Celebration Committee, organized an Amateur Radio special events station with assistance from the Hamilton Amateur Radio Club (HARC). The special event call signs VB3HAIDA and VB3HAIDA80 were procured for the event. HARC Vice-President John David, VA3JHD, organized the volunteers to run the station and he also provided the use of his personal Icom IC-9300 transceiver.

Tom Godden, VE3TWG, of the Burlington Amateur Radio Club, put a special logbook together as a memento of the event. Between August 12 and August 28, there were 218 contacts made in Canada and the United States mostly on 7.180 kHz using SSB. Visitors to Radio 1, were encouraged to try their hand at sending Morse code by using a code practice oscillator. The above photo shows (from left) Rick Bialachowski, VA3WWV, John David, VA3JHD, James Thomas, VA3JT, Tom Godden, VE3TWG and Barry Lisowski, VE3ISX, who operated VB3HAIDA80 in Haida's Radio 1. Photo provided by John David.

For more photos visit <https://hamiltonarc.com/events/Haida/index.html>.

Visit: <http://hmcshaida.com> and <http://jproc.ca/haida>

## Coming Events

New URL: <https://hambone.ca/rac/events/upcoming.php>

### Iroquois Amateur Radio Club Hamfest

**Date:** Saturday, April 6.  
**Place:** Iroquois, ON; The Royal Canadian Legion Branch 370 at 24 Dundas Street  
**Time:** Vendors 8 am; Public 9 am.  
**Cost:** Admission: \$5 which includes a ticket for a door prize. Table Rentals are \$10 each.  
**Talkin:** Iroquois repeater VE3IRO 145.290 (-) CTCSS 100.0 Hz.  
**Info:** General info Janek at [va3xar@gmail.com](mailto:va3xar@gmail.com) and for tables contact Mike at [va3tufham@aol.com](mailto:va3tufham@aol.com) or Janek at [va3xar@gmail.com](mailto:va3xar@gmail.com)  
**W:** <https://IroquoisARC.ca>

### Simcoe County Hamfests sponsored by Simcoe County Amateur Radio Enthusiasts

**Date:** Saturday, May 11.  
**Place:** Barrie, ON; Grenfel Community Centre, 1989 Sunnidale Road (County Road 40).  
**Time:** Vendors 8 am; Public 9 am.  
**Cost:** Admission free. Vendors \$5. Donations to the Grenfel Community Centre Building fund are greatly appreciated.  
**Talkin:** 146.55 MHz simplex no tone.  
**Info:** Brant Smith, VE3UME at 705-733-0554 or [ve3ume@scare-radio.com](mailto:ve3ume@scare-radio.com)  
**W:** <http://scare-radio.com>

*The RAC Events Database is courtesy of our great volunteer Neil Herber, VE3PUE, at new URL <https://hambone.ca/rac/events/upcoming.php>*

## NEW YEAR'S SPECIALS

### Antennas

Cushcraft A-503S & A-505S 6m Beams  
 Hy-Gain TH-3MK4 & TH11DX HF Beams  
 MFJ-1724B 2/440 MHz & MFJ-1728B Mobile  
 MFJ-1778 All Band G5RV Antenna Rotators  
 Refurbished Hy-Gain T2X & HAM-1V  
 Yaesu G-800DXA | G-1000DXA | G-2800DXA

### Trylon Towers New and Used

RG-8 Mini Coax .79/ft; 200 feet \$149  
 RG-213 Coax 1.39/ft; 200 feet \$269  
 LMR-400 Coax 1.69/ft; 200 feet \$309  
 450 Ohm Ladder Line .65/ft; 200 feet \$119  
 14/7 HD Copper .27/ft; 200 feet \$49  
 12/7 HD Copper .32/ft; 200 feet \$59  
 1/8" Dacron Rope .22/ft; 100 feet \$20  
 3/16" Dacron Rope .25/ft; 100 feet \$23  
 1/4" Dacron Rope .35/ft; 100 feet \$32

### H.C. MacFarlane Electronics Ltd.

5683 Battersea Road, ON K0H 1H0  
 Call Harold, VE3BPM, or Tom, VE3UXP,  
 or Victor (B.Eng and MSc)  
 Phone 613-353-2800  
 Email: [macfld@kos.net](mailto:macfld@kos.net)  
[www.macfarlaneelectronics.on.ca](http://www.macfarlaneelectronics.on.ca)

**Stay Safe and Stay Healthy!**



## My Evolving Journey in Amateur Radio

Cal DiFalco, VA3CDV

Ever since my childhood, the fascination with radios has been a part of my DNA, an inheritance from my father who was constantly engrossed in tinkering with his 1941 Philips multiband tube radio.

Several years ago, I decided to delve into the realm of Amateur Radio, fuelled by a stubborn determination to be a self-learner. Looking back, I am not entirely sure if it was the wisest approach, but it did work out for me eventually.

When embarking on the journey to purchase my first radio, my Elmer, a seasoned mentor in the Amateur Radio community, wisely advised the "buy once, cry once" strategy. In essence, he suggested investing in a new and reputable brand rather than opting for a used radio that might require upgrades in the future, potentially proving just as expensive if not more so. Following this advice, I acquired the Yaesu FT-991A all-band, multimode portable transceiver – a decision that I have been content with ever since.

As months rolled by, I sought the next milestone in my Amateur Radio journey, which materialized in the form of WIRES-X (Wide-coverage Internet Repeater Enhancement System). Connecting to the internet opened up a global network, allowing me to communicate with fellow enthusiasts worldwide. While the crystal-clear reception offered by WIRES-X was undeniable, I found myself torn between its convenience and the traditional charm of manually hunting down contacts, fine-tuning frequencies, and navigating the challenges posed by interference and other factors. My solution? Embrace both worlds, seamlessly transitioning between WIRES-X and traditional Amateur Radio operation based on my mood and preferences.

The pursuit of knowledge in amateur radio led me to take on the advanced exam, once again opting for self-study. Despite the inherent challenges, I passed. Subsequently and most recently, I decided to tackle Morse Code (CW) as my next endeavor. Once again, self-study became my modus operandi, with CW evolving into a language I became increasingly fluent in. In a testament to the strength of our marriage, even my lovely wife Teresa got involved, practicing Morse Code with me.

Support from my Elmer and the camaraderie fostered by the Hamilton Amateur Radio Club (HARC; see page 59) played a pivotal role in my journey. I vividly recall tapping out Dits and Dats on my steering wheel, decoding licence plates as part of my CW practice – an unconventional yet effective method that I highly recommend. As for what lies ahead, the vast landscape of Amateur Radio offers numerous unexplored territories. While I may not consider myself a Parks On The Air (POTA) enthusiast at the moment, the allure of uncharted aspects keeps the excitement alive.

To those reading this account, my advice is simple: learn at your own pace, never underestimate your capabilities, and do not hesitate to seek help when needed. Through my interest in Amateur Radio, I have been fortunate to encounter a multitude of kindred spirits and, perhaps, that is the most rewarding aspect of this captivating journey.

Please send tales of your "Journey in Amateur Radio" to [tcamag@yahoo.ca](mailto:tcamag@yahoo.ca).

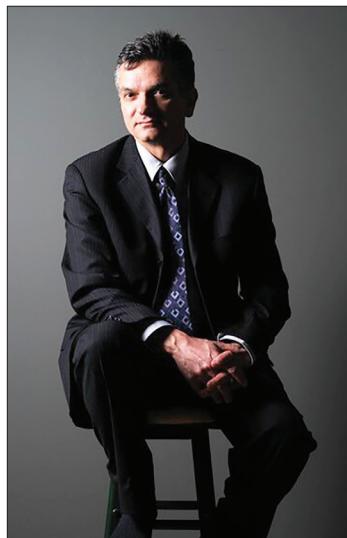

## GOTA Success at Field Day

Larry Bloom,  
VE7LXB

This year for Field Day, the American Radio Relay League gave emphasis to "Get On The Air" (GOTA) stations and Surrey Amateur Radio

Communications (SARC) decided to give it a priority due to the bonus point potential.

Although our GOTA participation has been minimal in past years, in no time we had a motivated group of new Amateurs backed by the full support of our club Directors.

**Caption: GOTA coach Anton, VE7SSD, offers suggestions to Dale, VE7LWT, Ernie, VE7ODK and Katrina, VA7WBT**

Beginning at 11 am PST, our GOTAs began transmitting out of the Surrey Emergency Program Amateur Radio (SEPAR) trailer using an IC-7610 transceiver graciously lent to us by Icom. The IC-7610 is an HF (shortwave) transceiver, and one of the high-end models in the marketplace.

For the next 24 hours, we ran, we pounced, and we spun the dial on the 15, 20, 40 and 80m bands, utilizing our 110-foot "Bigfoot" mobile tower with a TH-7 Tribander – a TH-7DX, 7-element, broadband Tri-Band Beam for 10, 15 and 20 metres.

Given their lack of HF experience, we had one new Amateur transmitting while another logged. After an hour, the operator took a break, the logger took the operator's place, and another GOTA sat in the logging chair. I was amazed at how quickly the new Amateurs picked things up. Our biggest issue was convincing them to relinquish the mic! Exhaustion set in by 11 am on Sunday morning, but we knew that we had accomplished something special.

Well, the results are in! Our GOTA and regular club QSOs were combined in the 2F category and we came **first** in Canada and **third** overall!

Congratulations to: Doug De Jong, VE7JDJ, Lesley Verhulst, VE7CMI, Katrina Reynolds, VA7WBT, Dale Burghall, VE7LWT, Mike Porisky, VE7YEG, "UB" Adabi, VE7UBZ, Ernie Symchych, VE7ODK, Alex Sevostiyonov VA7PVC, Dmitry Sevostiyonov, VA7DVO, Larry Bloom, VE7LXB, and Manvir Judge, VA7BKI, for their efforts and enthusiasm. Thanks also to GOTAs Aravind, De and Gary who visited to cheer us on.

We know that we can't compete as GOTAs next year, but we're confident a fresh crop of new Amateurs will do us proud at Field Day 2024.



# Decades of Dedication: Celebrating 90 Years of the Halifax Amateur Radio Club (HARC)

**John Bignell, VE1JMB**

As the current President of the Halifax Amateur Radio Club (HARC), it's my privilege to share our remarkable history as we celebrate our 90th anniversary. HARC's inception in 1933 marked a significant milestone in Amateur Radio history in North America, making it one of the region's oldest and most continuously active clubs. Our founding culminated in a vibrant Amateur Radio community in Halifax that has been growing since the 1920s.

During this pioneering era, the Naval Service of Canada began issuing Amateur Radio licences, recognizing the burgeoning interest in radio communication. Frank Vaughan of Saint John, New Brunswick, received the first Canadian Amateur Radio licence. Nova Scotia, along with Prince Edward Island and New Brunswick, represented under the call sign prefix "one", was at the forefront of this movement. By 1920, the local Amateur Radio roster included George Sandoz (1AH) and P. L. Whitman (1AI), growing to 42 stations by 1927.

Among our early luminaries was Bill Borrett (1DD) of Dartmouth, who achieved the first transatlantic contact from the area in 1923 and later played a pivotal role in international Amateur Radio affairs. The formation of the Royal Order of Trans-Atlantic Brass Pounders (ROTAB) in 1924 further highlighted the achievements and community spirit among radio operators.

This sense of community and shared passion led to the Maritime Amateur Radio Association (MARA) formation in the late 1920s. However, as the number of Amateurs in Halifax grew, it became clear that MARA's scope needed to be changed. This realization led to the birth of the Halifax Amateur Radio Club in 1933, reflecting a more focused representation of Halifax's radio enthusiasts.

In the early days, HARC meetings were held in members' homes, fostering a sense of intimacy and camaraderie.

By 1936, the club's growth necessitated a move to the Halifax YMCA. The first east coast hamfest in 1935 was a milestone event showcasing our commitment to technical achievement and community building.

These early formative years were about more than just radios; they were about creating a community bound by a shared passion for wireless communication. From its modest beginnings, the Halifax Amateur Radio Club has become a cornerstone of the Amateur Radio community in the maritime region and remains a proud and active entity in the Amateur Radio world.

Since its establishment, the Halifax Amateur Radio Club has significantly contributed to public service, particularly during emergencies and disasters. This role is fundamental to the ethos of HARC, highlighting the importance of Amateur Radio as a resilient and reliable communication medium.

One of the most notable instances of HARC's early commitment to public service was during the Moose River Gold Mines disaster in April 1936. This event drew international attention as HARC members were crucial in providing essential communication support. This past spring, on the anniversary of the disaster, our team and those of other Amateur clubs responded to the Moose River site and activated the park as a Parks On The Air (POTA) event.

HARC's involvement in emergencies extends beyond singular events. The club has been integral to the community's emergency preparedness plans, working closely with Nova Scotia government agencies and emergency services. Training and readiness exercises are regular activities for HARC members, ensuring they are equipped to provide



communication support whenever needed. HARC wireless operators stepped in when traditional communication lines failed or were over-taxed, offering rescue operations lifelines and

relaying critical updates to the public and concerned authorities. The effectiveness of Amateur Radio in this crisis underscored its value in emergencies, where it can function even when other systems are compromised.

Moreover, HARC's role in emergencies also encompasses educating and training new generations of Amateur Radio operators, emphasizing the importance of Amateur Radio in emergency communication. This proactive approach to community engagement and readiness highlights HARC's ongoing commitment to public service.

HARC's contributions have not only underscored the pivotal role of Amateur Radio in modern communications, but have also solidified our reputation as a reliable ally in ensuring community safety and effective emergency response. Our history shines as a beacon, highlighting the invaluable presence of Amateur Radio operators during crises, adeptly closing communication gaps and offering essential links under the most challenging conditions. In the past few years, HARC members played a crucial role in responding to the Tantallon and Shelburne wildfires, Nova Scotia floods, and Hurricane Fiona, collaborating seamlessly with various disaster response agencies. Our involvement in these responses exemplifies our unwavering commitment to service in times of need.

As the Halifax Amateur Radio Club celebrated its 90th anniversary this past summer, the milestone event vividly showcased our rich history and commitment to Amateur Radio and community service.



"The core event on Saturday, August 19 was a big hit. We partnered with RAC to web-stream the presentations, attracting online participation. Show and Shine highlighted various command and control vehicles, while the Gala Dinner served as a platform for discussing the future of Amateur Radio. Awards for special call sign use and the QSO Party were also presented. The final day featured a service for First Responders and free museum access arranged by Gord VE1GVY. Door prizes were awarded, with a final one to be decided in the upcoming club meeting. The demographic was a mix of HARC and RAC members, first responders, Emergency management groups, along with others from the general public. Making this event one of the largest Ham event in eastern Canada. We owe immense thanks to the planning committee and all presenters. Their hard work made this monumental celebration possible." – Ritchie Long, VE1RL: 2nd VP & 90th Planning Chair" Courtesy of the September 2023 issue of the Halifax ARC's "Reflector". Photos by John Bignell, VE1JMB.

The celebration started with the "Touch a Truck" event, an interactive exploration of emergency service vehicles and equipment. This unique opportunity allowed attendees to closely examine the Nova Scotia Communications, Halifax EMO communication trailer, The Salvation Army Emergency Disaster Services Mobile Canteens and Halifax Police Command units. More than just a display, this event offered hands-on experiences with Amateur Radio setups and equipment, highlighting its educational and technological aspects.

In addition to the hands-on experiences, the anniversary event featured various speaker sessions, enriching the understanding of Amateur Radio and its applications. The conference floor was abuzz with displays from multiple Emergency Management Organizations (EMOs), including the Canadian Red Cross,

showcasing their vital roles in crisis management and how Amateur Radio integrates into their communication strategies. A highlight for many was the wireless room setup, a unique space where participants could connect with Amateurs worldwide. This global interaction demonstrated the far-reaching capabilities of Amateur Radio and allowed attendees to experience firsthand the thrill of international communication.

The following day, we paid tribute to the unsung heroes of communication – professional and amateur wireless operators and 911 dispatchers. A unique service at the Salvation Army Halifax West community church saw community members coming together to appreciate their dedication to public safety. This day of recognition was complemented by a communal BBQ, fostering camaraderie and celebrating HARC's achievements.

The atmosphere was festive and full of fellowship, honouring our club's long-standing tradition in Amateur Radio and community involvement.

As we close the curtains on our 90th-anniversary celebrations and on the year 2023, we extend our heartfelt gratitude to all members, past and present, who have shaped the Halifax Amateur Radio Club into the remarkable community it is today. Their dedication, enthusiasm and expertise have enriched our club and significantly contributed to the broader Amateur Radio field. This anniversary is a testament to their collective efforts and unwavering spirit.

We look forward to continuing this legacy, building on their solid foundation, and venturing into the future with the same passion and commitment that have been our hallmark for nine decades.

# Roaming Up North: VY1RST, KL7RST, VE8RST and VY0RST

John Reisenauer, KL7JR (Johnkl7jr@gmail.com)

Several years ago, Steve Ford, WB8IMY, of the American Radio Relay League (ARRL) fame, assisted me with publishing my first Amateur Radio book "Go North John"!

Now I'm reliving old memories and creating new ones up north operating the North Country DX Association's (NCDXA) "RST" clubs – VY1RST, KL7RST, VE8RST and VY0RST.

## Stewart, British Columbia and Hyder, Alaska Border

Hyder is the only Alaskan town you can drive to without going through the Yukon. From Hyder it's 400 miles north to the Yukon and the world-famous Alaska Highway (aka Alcan Highway). My sister Carol accompanied me for her first visit to Alaska. Hyder enjoys many of the amenities such as groceries, fuel and hardware offered by neighbouring Stewart, British Columbia. Hyder children attend school in Stewart.

I enjoyed a terrific opening on 40m using KL7RST/p KL7. Using my 75m T Vertical, I worked: N0PUI, VE3CMB, WN1F, K9GWS, K4JEL, K6ODI, WK1J, K9DBB, AI4K, KU1V/p NH, KL7OR, KF7HNC and W0JKT. I only heard a few weak stations on 75m. My antenna arsenal: MFJ Hamsticks for 40m and 75m, homebrew G5RV, Opek HVT-400B multiband vertical and homebrew 160 and 75m T Verticals.

Later the QRN picked up to S7 on 40m. KL7JR/p KL7 and VE7 plus KL7RST/p KL7 and VE7 both strained to hear anything above the noise. I did manage to work AE4NT/p WA, KL7OR, KF7HNC, AC2MT, W9WWG and KB0EL before the band was totally consumed in QRN. I was using my 160m Vertical T. The 75m late net was also rough allowing only contacts with: N0PUI, AA1NA, KF7HNC, AE4NT/p WA, KL7OR and K4JEL. The rain, sleet and wind continued to pound my motorhome throughout the night.

## Upper Liard at the BC/Yukon Border

On April 9, we reached a rest area at Upper Liard, Yukon where I've operated from before. I parked my motorhome between the Yukon and British Columbia road signs. It didn't take long to erect my 75m T Vertical, which loaded just fine on 40m. We saw two herds of caribou on the highway up from Hyder. No snow. No rain. What a treat. On 20m I worked KL7HRN, KL1MS, NA6JD, N7XUH, VE3KG and KG7TX before lunch. The 40m net slowly deteriorated with time but I did manage to work N0PUI, K6ODI, K4JEL, AA0HF, KJ6EEP and KL7OR.



## Caribou RV Park in Whitehorse

Late the following day we arrived at Whitehorse, the capital of the Yukon. We found the Walmart to replenish supplies then we settled into our campsite. I put up my 40m and 75m verticals, mast-mounted off the mirrors as I've done in the past. Later on 40m, S9 noise prevailed but later settled down a bit. KL7JR/p VY1 and VY1RST (fixed) worked W8NET, W6PNY, KU1V, W9ROG, WN1F, K7QHU, WG0I, AE4NT/p WA, KL7OR, K9DBB, AI4K, K4JEL, K10Y and N0PUI. The temperature was about 25°F outside but a pair of 1500 watt electric heaters kept us comfortable. We woke up to an 8°F crisp Whitehorse morning. It was nice to have cell service, Wi-Fi and a laundromat.

On Day 2, April 12 on 40m KL7JR/m VY1 and VY1RST worked WA0ROH, N0PUI, W6PNY, KL7OR, KR0DS/p OR, KB0EL and a few others under extremely poor conditions. S9 noise with weak signals prevailed.

## Kluane National Park, Yukon

We arrived at Kluane National Park on April 12, only a short 150-mile drive from Whitehorse. We parked at Soldiers Summit on beautiful Kluane Lake near the park's visitor centre which was closed for the season. Kluane Lake and the park has the most beautiful scenery in the Yukon and it takes your breath away! It has always been my DX spot of choice for camping, contesting or island activating.

It was time for KL7JR/m VY1 and VY1RST/m VY1 from Kluane National Park to see what the 40m late net was like. To my luck, I stumbled upon relay station W6PNY who was loud and got me checked in. I managed to work the following on a deteriorating 40m band: N0PUI, KL7OR, W6PNY, WY6N, KB2ENF, AA1NA, KU1V and AE4NT/p AZ. I was happy to work all I could!

## Fort Liard, Northwest Territories

We camped just outside of the small Indigenous community that I've operated from several times over the years. I operated on 40m using KL7JR/m VE8 and VE8RST/m VE8. The QRN continued to plague me. N0PUI in Minnesota was my sole contact. So ends another exciting and challenging trip north. If you'd like to ride along check out the trip video produced by KB1XP.

– 73, Yukon John, KL7JR



# RAC Challenge / Operating Awards



Robbie Morrison, VE7NB, conducts his POTA activation from Marine Rail Park (VE-5775) near the Confederation Bridge on Prince Edward Island. His carry-on fly-away kit is comprised of a Yaesu FT-891, 20m end-fed half-wave (EFHW) antenna, 50-foot coax, and a 12AH Bioenno battery.

Robbie continued on his return journey home to Metro Vancouver, British Columbia, to activate parks in Quebec and Ontario to finalize his eligibility for the POTA "Activated from All Canadian Provinces Award."



Paul Mower, VA6MPM, received the Gold Coureur des Bois award in October for having completed 100 activations:

"Just received my gold award. Each of my more than 100 portable operations were a separate SOTA summit.

Since the beginning of the program, I have done over 100 separate summits.

I have included some photos of some of the more memorable recent summits."

## The RAC Challenge Update

### Ante Laurijssen, VA2BBW

For those of you who have been following the RAC Portable Operations Challenge leaderboard these last few months, you will have no doubt noticed that the battle for the top spots, unlike the weather, is heating up! I am very excited to see what happens in the last stretch of 2023, but for now, let's have a look at September and October and see what has been going on.

September was full of activity, with 19 different participants from across the country, a few even operating from multiple provinces. In fact, Robbie Morrison, VE7NB, operated from Saskatchewan, New Brunswick, Prince Edward Island, Quebec, Ontario and British Columbia this month alone!

There was also a multitude of Parks On The Air and lighthouse activations, and a few Summits (SOTA) and Islands (SOTA) on the air as well. A breakdown of the top five spot is provided below. There were also three recipients of the prestigious Coureur des Bois award in September. Stuart Hayes, VE3RGO and Steve Kavanagh VE3SMA, received the Silver Award and Paul Mower, VA6MPM, achieved Gold.

October also saw good participation, with 16 operators sending out their signals from six different provinces. And although no Coureur des Bois awards were issued, we had one Amateur, Jim Langille, VE1JBL, conduct his first POTA activation! The results for the spookiest month of the year are shown below. The results don't say anything on their own. What gives them value are the stories and people behind them. Here are a few that were shared with me from our participants. How about those amazing views!

RAC Challenge Top 5: September 2023		
Place	Name/Call	Points
1st	Nicolas Gagnon, VA2VT	520714
2nd	Richard Pierik, VE1RPX	331800
3rd	Stuart Hayes, VE3RGO	132182
4th	Gerry Bell, VE3PYJ	77248
5th	Steve Verhoef, VE3WLX	62492

RAC Challenge Top 5: October 2023		
Place	Name/Call	Points
1st	Richard Pierik, VE1RPX	229844
2nd	Stuart Hayes, VE3RGO	54600
3rd	Michael Van Kuyk, VE7KPZ	37260
4th	Mike Bingley, VE6FXL	35048
5th	Gerry Bell, VE3PYJ	29442

Coureur des Bois: September 2023	
Gold:	
Paul Mower, VA6MPM	
Silver:	
Stuart Hayes, VE3RGO Steve Kavanagh, VE3SMA	

For more information about the RAC Portable Operations Challenge Award please visit: <https://www.rac.ca/rac-challenge/>

In the same vein, Jesse DePlonty, VE6JTW, sent us a photo of his first snow activation of the season, from Mockingbird Hill, SOTA VE6/HC-255.

I also received this report and photo from Christopher Lang, VE7LRV:

“Did a short POTA activation at a local park, Elk/Beaver lake just north of Victoria, British Columbia.

Ran my 705 at 5 watts into a Micro PA-50, outputting about 50 watts on voice peaks. 30 SSB contacts were all I had time for this Saturday session. Using a Chelegance MC-750 quarter-wave vertical. A wonderful sunny day on the thanksgiving long weekend!”

I also received a few reports from Michael Van Kuyk, VE7KPZ, who shares many of his activities on his club’s website at <https://norac.bc.ca>, as well as from Tom Cort, VA2NW, Pierre Jolin, VE2GT, Steve Verhoef, VE3WLX, John McGrath, VE3FDZ, and Jerry Spring, VE6TL.

I have set up a page on the RAC website dedicated to sharing your Portable Operations Challenge stories and adventures with the rest of the world. Please keep them coming, I always love seeing them cross my inbox. Also, don’t forget that I will be crowning the 2023 winners in the next report, so stay tuned! And best of luck to all the participants.

## Operating Awards Update

During the past few months I have been quite busy behind the scenes with other RAC volunteers working on updating our Operating Awards program, and I am very happy with the progress we have made so far. With the help of the members of the Contests and Awards Committee, the IT Committee and the Marketing Committee, we have come up with two new awards: the Canadian Century Club Award and the Worked All North America Award. We have also been pushing new



ideas forward for integrating the award application process into the RAC website – and we are almost there.

Also, thanks to the hard work of some of our volunteers, we have been able to repatriate almost all of the V\*\*RAC call signs and have added them to the list of valid calls you can work for the Worked All RAC award. And now that things are brewing at headquarters, we have been able to add VA3RHQ and VE3RHQ to that list of call signs as well! RAC wishes to sincerely thank Eric Telfer, now VA3EHT, for donating his original VE3RHQ call sign to RAC so that it can be used at our headquarters for its upcoming Amateur station. VE3RHQ will be well used in future RAC contests and events.



*A very special mention goes out to Steven W. Hines, N2PQJ, for being the first recipient of our new Canadian Century Club award! Steven had originally contacted me about the now defunct Trans-Canada Award, which he had been working towards for a long time. Being a little disappointed that he would not be able to add it to his collection, I mentioned our new award, and said that if he was interested and qualified for it, he would likely be the first recipient. Well, within a day or two he had gone through his confirmations and QSLs and sent me the completed, signed application form. And once he received his award, he was kind enough to send me a great picture of himself proudly displaying his new achievement. Doesn’t he look happy?*

I also want to give a shout out to Chris Bisailion, VE3CBK, who is the first recipient of our new Worked All North America award. What’s even cooler is that this was all done at QRP power levels! Chris, we’ll be expecting a picture with your award as well for the next report, just like Steven.

I would also like to extend a special thank you to Julien Bolduc, VY0MEL, who has recently decided to upload his Nunavut logs to Logbook of The World (LoTW). The latest batch of Canadaward applications I received can in part be attributed to this, and I’m glad to see activity from Nunavut being confirmed online. We all appreciate this.

I am very pleased with the positive feedback that the team and I have been getting, as well as with the number of applications and general interest in our RAC Operating Awards. For any questions or information about our operating awards program, please contact me at [awards@rac.ca](mailto:awards@rac.ca). Oh and take a look at the ad on the next page. I think you will like it.

– 73, Ante Laurijssen, VA2BBW





**Enjoy access  
to exclusive  
insurance rates**

**Accédez à des  
tarifs d'assurance  
exclusifs**



**Radio Amateurs of Canada** has  
partnered with **The Personal** to offer you:

**La Radio Amateurs du Canada** fait équipe  
avec **La Personnelle** pour vous offrir :



**Group home and auto rates  
not available to the public**



**Des tarifs d'assurance auto  
et habitation avantageux**



**Additional savings  
and discounts**



**Des économies et des  
rabais supplémentaires**



**Personalized support to find  
the coverage you really need**



**Un soutien personnalisé pour  
répondre à vos besoins uniques**

  
**thePersonal**  
Home and Auto Group Insurer  
**Group rates. Preferred service.**

  
**Radio Amateurs  
du Canada**

  
**laPersonnelle**  
Assureur de groupe auto et habitation  
**Tarifs de groupe. Service unique.**

**[thepersonal.com/radioamateurs](http://thepersonal.com/radioamateurs)  
1-888-476-8737**

**[lapersonnelle.com/radioamateurs](http://lapersonnelle.com/radioamateurs)  
1 888 476-8737**

The Personal refers to The Personal Insurance Company. The Personal® and related trademarks are trademarks of The Personal Insurance Company, used under licence. Certain conditions, limitations and exclusions may apply.

La Personnelle désigne La Personnelle, compagnie d'assurances. La marque La Personnelle<sup>MD</sup> ainsi que les marques de commerce associées sont des marques de commerce de La Personnelle, compagnie d'assurances, employées sous licence. Certaines conditions, exclusions et limitations peuvent s'appliquer.

# MEET OUR NEW AWARDS FAMILY

# RENCONTREZ NOTRE NOUVELLE

# FAMILLE DE PRIX



We are thrilled to unveil our new Operating Award certificates: Canadaward, Worked All RAC, Canada Century Club and Worked All North America Award.

Nous sommes ravis de dévoiler nos nouveaux certificats de prix d'exploitation : Canadaward, Worked All RAC, Century Club Canadien et Worked All North America Award.



## Challenge yourself – Mettez-vous au défi



# Radioworld.ca

4335 Steeles Ave. West, Toronto, ON M3N 1V7

Phone 416-667-1000 Fax 416-667-9995

email: [sales@radioworld.ca](mailto:sales@radioworld.ca)

*Canada's largest selection of Amateur Radio brands and products!*

## **YAESU**

### **FTM-500DR**



## **New Flagship Mobile Transceiver**

We are pleased to announce the new FTM-500DR 50W, C4FM/FM, 144/430MHz, Dual Band Digital Mobile Transceiver. The FTM-500D shares the Yaesu core features, utilizing the latest C4FM Digital technology with many new features and improvements.

**Contact Radioworld or Radioworld Central for details today!**

*Providing Canadian customers competitive prices for over 2 decades!*

# central Radioworld

8, 711 48th Ave., S.E., Calgary, AB. T2G4X2

Phone 403-239-1400 Fax 403-239-1408

email: [sales@radioworldcentral.ca](mailto:sales@radioworldcentral.ca)