



Canada's Amateur Radio Magazine La Revue des Radioamateurs Canadiens

JULY / AUGUST – JUILLET / AOÛT 2015

**RAC Annual General Meeting:
Saturday, July 4 at the
Saskatchewan Hamfest**

“An interesting adventure” at Klukshu...

Publications Mail Agreement # 40028682 – Registration # 09866



The Yaesu FTM-400: A look inside

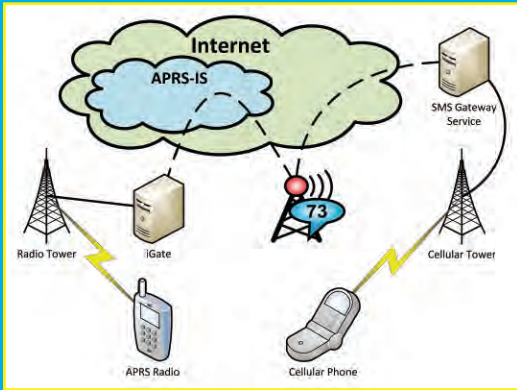

APRS and SMS Converge

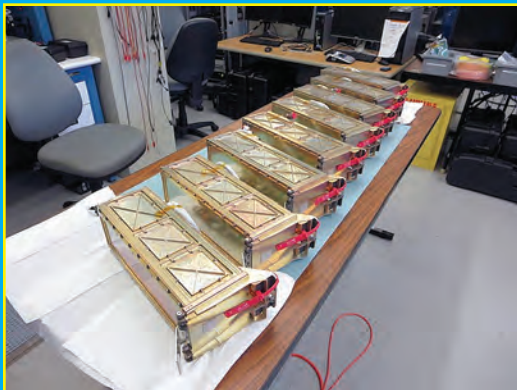

**ElaNa Mission XII P-Pods (including Fox-1A's)
just prior to final integration into their carrying
structure. (Courtesy: CalPoly via AMSAT)**

RFinder, RAC's Official Repeater Directory now finds repeaters over routes...on the web, and now in RT Systems radio programmers. So take that drive from Signal Hill to Vancouver but pre-program your radio for the trip!



RFinder - The World Wide Repeater Directory now finds repeaters over routes worldwide! Support RAC by choosing RFinder as your repeater directory.

Find RFinder in Google Play, the Apple App Store on your iPhone/iPad/iPod Touch or on the web at www.rfinder.net for only \$9.99[usd]. Use RFinder in your favorite radio programmer such as RT Systems or CHIRP or access it at <http://web.rfinder.net>. Generate TPE files or POI files for your favorite GPS! Coming soon to Blackberry!

RFinder Liste des relais

WWRD-Annuaire Relais Officelle du Canada

VA3ODG C/Ottawa
0 km IRLP Echo: DSTAR
145.53 MHz (-) PL:88.5 All*

Manotick ARG/Ottawa
0.32642 km IRLP Echo:
145.45 MHz (-) PL:151.4 All*

VE21
0.947
WWRD-Official Repeater Directory of Canada

XMJ225/Weatheradio-Toronto

VE21
1.2415 km IRLP Echo:
4.701 162.4 MHz () PL:0.0 All*

VE3OC/Toronto

VE21
6.5451 km IRLP Echo:
5.945 145.11 MHz () PL:82.5 All*:29307

N6SGX/Ontario

VE21
7.7948 km IRLP Echo:
145.53 MHz () PL:107.2 All*

VE3EVM-L
13.462 km IRLP Echo:500707
147.445 MHz () PL:103.5 All*

VA3AGC-L
14.553 km IRLP Echo:204876
147.51 MHz () PL:88.5 All*

Dist Freq Callsign Map More

www.rfinder.net/route-search.html

Repeater Directory Web - Route Search

Not registered for the RFinder Service?
Click here

User E-Mail: w2cyk@rfinder.net Password: *****

Location: [input field] [input field]

Start: signal hill newfoundland End: Vancouver BC

Waypoints: [input field] [input field] [input field]

Route Width: 20

Buttons: Add, Remove, Remove All, Move Up, Move Down, OK, Cancel

Map showing route from Chicago to Vancouver BC with waypoints.

**JULY & AUGUST
JUILLET & AOÛT
2015**

Editor / Rédacteur en chef
Alan Griffin
Email: tcamag@yahoo.ca

Advisors / Conseillers
Dave Green, VE3TLY
Frances Roach, VE3HKG
Gerry Trottier, VA3GLT
Norm Rashleigh, VE3LC
Mike Kelly, VE3FFK
Richard Ferch, VE3KI
Bill Karle, VE1YY
Len Morgan, VE9MY
Ken Grant, VE3FIT
Bob Kavanagh, VE3OSZ

Translation / Traduction
Ante Laurijssen, VA2BBW
Alan Bulley, VA2UK
Serge Langlois, VE2AWR
Noël Marcil, VE2BR
René Levesque, VE2CNJ
Claude Lalande, VE2LCF

**Technical Diagrams /
Schémas technique**
Stan Smith, VE3DDX

The Canadian Amateur is published by Radio Amateurs of Canada Inc. / The Canadian Amateur est publié par la société Radio Amateurs du Canada Inc.

Indexed in the Canadian Periodical Index / Enregistré à l'Index des publications canadiennes : ISSN 0834-3977

Publications Mail Agreement / Accord de publications diffusées #40028682. Registration / matricule #09866

The Canadian Amateur
720 Belfast Road,
Suite / Bureau 217
Ottawa, ON, Canada
K1G 0Z5
613-244-4367;
1-877-273-8304
tcamag@yahoo.ca
http://wp.rac.ca/

Printed in Canada by St. Joseph Communications
Ottawa, ON, Canada
Imprimé au Canada sur les presses de St. Joseph Communications
Ottawa, ON, Canada

Return Undeliverable Canadian Addresses to Circulation Department: 217-720 Belfast Road Ottawa, ON K1G 0Z5



"Made it to Klukshu on Saturday to replace the Repeater there. It was an interesting adventure as the weather was not ideal.

We called the helicopter at about 7:30 am and were in the air around 8 am. The helicopter was able to drop us (went with a Park's guy named David Blakeburn) at the top close to the comshell. The wind was fierce – likely 80 km/h or so. Temperature was a few degrees below zero.

As there were lower clouds moving in and out, the helicopter couldn't wait for us so we departed and found a nice flat spot a few hundred metres below. We did the repeater swap and tested everything as quickly as possible as the heli had a deadline for another job."

– see page 53 for the complete story

Note: TCA is best viewed in colour on the RAC website at <http://wp.rac.ca>

ARTICLES WANTED

We would love to receive your articles – both technical and non-technical.

Please send them to the TCA Editor at tcamag@yahoo.ca.

The deadlines for the next issues of TCA are July 15, September 15 and November 15.

For RAC Membership Inquiries and Change of Address please contact RAC HQ at: rachq@rac.ca

NATIONAL & INTERNATIONAL

RAC Management Team 4
 RAC President's Message..... 6
 Un message du président de RAC 6
 Annual General Meeting / Assemblée générale annuelle..... 10
 Saskatchewan Hamfest / Le Hamfest de la Saskatchewan..... 10
 WRC-15 Update: Conference Preparatory Meeting, Bryan Rawlings, VE3QN..... 17
 Call for Nominations: The Canadian Amateur Radio Hall of Fame.. 18
 Mise ne nomination : Temple de la Renommée des Radioamateurs Canadiens 18
 Call for Nominations: RAC Amateur of the Year Award..... 19
 Mise ne nomination : Rix amateur de l'année de RAC 19
 RAC Simulated Emergency Test..... 50

TECHNICAL

Easy-to-Build VHF Yagis, Steve Kavanagh, VE3SMA..... 11
 Amateur Radio Satellites, Keith Baker, VA3KSF 14
 Yaesu Fusion Technology, Mike Richards, G4WNC20
 QUA – A Topical Digest, Allen Wootton, VE7BQO.....23
 A QRP Power Meter, Tom Hardy, VE4AKI 34
 All Things Digital, Amateur Radio for the 21st Century, Robert C. Mazur, VA3ROM.....36
 APRS and SMS Converge, Paul Dufresne, VE30TB42

DEPARTMENTS

TCA Advertising Index..... 2
 Silent Keys..... 3
 RAC QSL Bureau System 3
 Feedback: Letters to the Editor..... 5
 Help Wanted..... 19
 RAC Membership / Adhésion de RAC..... 31, 32
 Defence of Amateur Radio Fund 59
 Coming Events 63

NEWS

RAC Section Manager Appointed for Ontario South 7
 New RAC Website 7
 Nouveau site de RAC 7
 RAC Comments on ARRL Proposed Changes to US HF Band Plans.. 7
 Commentaires de RAC à propos des changements au plan de bandes HF des É-U. proposés par l'ARRL 7

OPERATING

<i>Six Metres and Down, Dana Shtun, VE3DSS</i>	8
<i>Southern Amateur Radio Hospitality, Ron Walsh, VE3GO</i>	25
<i>Radios that Helped Win WWII, Frank Gue, VE3GUE</i>	29
<i>Fresh On The Air – Adventures for the New and Beginning Ham, Phil Boucher, VE3BOC</i>	30
<i>YL News and Views, Val Lemko, VE5ACJ</i>	see next TCA
<i>Random Thoughts, Dirk Moraal, VY1NM</i>	41
<i>The Response to the Nepalese Earthquakes, Phil A. McBride, VA3QR/VA3KPJ</i>	44
<i>Public Service / ARES Column</i>	46
<i>Guides on the Air in British Columbia, Marcy Lui, VE7JT</i>	46
<i>Kitchener-Waterloo ARC: Emergency Services, Larry Gorman, VE3LGN</i>	48
<i>A Simple Desktop Stand, Don Dorward, VA3DDN</i>	49
<i>The Value of a Certified Emergency Coordinator, Bill Boskwick, VE4BOZ</i>	50
<i>RAC Simulated Emergency Test</i>	50
<i>SATS and SHARP, Robert Striemer, VE4SHS</i>	51
<i>Viewing Whitehorse from Above, Ron McFadyen, VY1RM</i>	52
<i>“An interesting adventure...”, Ron McFadyen, VY1RM</i>	53
<i>Dealing with Radio Frequency Interference, Gary Bartlett, VE1RGB</i>	54
<i>The Sports Page – The Canadian Contest Scene, Bob Nash, VE3KZ</i>	55
<i>C4HQ in IARU HF World Championship Contest</i>	59
<i>Section News – The RAC Field Organization Forum</i>	60
<i>Message from the RAC Chief Field Services Officer</i>	60
<i>RAC Field Organization Reports / National Traffic System Net Reports</i>	62
<i>Coming Events: The Hamfest and Fleamarket Calendar</i>	63
<i>CZ2F: 50th Anniversary of the Canadian Maple Leaf Flag</i>	64

PLEASE SUPPORT OUR ADVERTISERS

<i>Coax Publications Inc.</i>	35
<i>Fleetwood Digital Products</i>	43
<i>Hamstudy.com</i>	5
<i>H.C. MacFarlane Electronics Ltd.</i>	64
<i>Maple Leaf Communications</i>	63
<i>Ottawa Amateur Radio Club Hamfest</i>	27
<i>QSL Cards by VE7DK</i>	48
<i>Quarter Century Wireless Association</i>	29
<i>Radio Amateurs of Canada</i>	19, 45, 55, 63
<i>Radioworld</i>	19, outside back cover
<i>RFinder</i>	inside front cover
<i>Royal Society of Great Britain</i>	inside back cover
<i>Yaesu</i>	33

The Canadian Amateur is published in Canada six times per year to provide Radio Amateurs, those interested in radio communications and electronics, and the general public with information related to the science of telecommunications.

Articles, reviews, letters, features, suggestions, photographs and essays are welcomed. Manuscripts should be legible and include the contributor's name, call sign, phone number(s) and addresses (mail, email and packet, as applicable).

For a complete Author's Guide visit:
<http://wp.rac.ca/p155/>

The contents of this publication are copyright, and may not be reproduced without prior consent except by a bona fide Amateur Radio organization which may reproduce them provided the author and *The Canadian Amateur* are acknowledged.

The Advertising Department of *The Canadian Amateur*, on behalf of the magazine, wholly disclaims any responsibility for the content of any advertisement contained herein and makes no representations on behalf of *The Canadian Amateur* as to the truth of any statement contained in any such advertising.

Radio Amateurs of Canada Inc., and the publisher and editor of *The Canadian Amateur*, hereby disclaim any responsibility for any statement of opinion or other statement that may be contained in any article published by *The Canadian Amateur* and any such statement of opinion or other statement contained in such article is solely the opinion of the author of the article and not that of Radio Amateurs of Canada Inc., or the publisher or editors of the magazine, unless it is specifically stated to be the case therein.

The Canadian Amateur is published by Radio Amateurs of Canada Inc., 720 Belfast Road, Suite 217, Ottawa, ON K1G 0Z5

Indexed in the Canadian Periodical Index:
ISSN 0834-3977.

Publications Mail Agreement No. 40028682.

Registration No. 09866.

The Canadian Amateur, publié six fois par an, est destiné à fournir aux radioAmateurs, à toute personne intéressée à la radio et à l'électronique et au grand public, des informations de toute nature relatives à la science des télécommunications.

Nous acceptons avec plaisir tout article, étude, suggestions, photos et lettres. Les manuscrits soumis doivent être lisibles et porter le nom de l'auteur, son indicatif, son ou ses numéros de téléphone ainsi que ses adresses postales, courriel et paquet s'il y a lieu. Si vous avez envie d'écrire pour TCA :
<http://wp.rac.ca/p155/>

Le contenu de la présente publication est protégé par copyright, tous droits réservés et ne peut être reproduit sans autorisation préalable dont est toutefois dispensé tout groupement reconnu de radioAmateurs sous réserve que ladite reproduction paraisse avec les mentions du nom de l'auteur et soit identifiée extraite de *The Canadian Amateur*. Le service publicité de *The Canadian Amateur*, agissant au nom de la revue, décline toute responsabilité quant au contenu des annonces publicitaires publiées et ne se porte en aucune façon garant de la véracité des propositions contenues dans lesdites annonces.

La compagnie Radio Amateurs du Canada Inc. ainsi que l'Éditeur et le Rédacteur en chef de *The Canadian Amateur* déclinent par les présentes toute responsabilité quant aux opinions exprimées ou autres déclarations pouvant apparaître dans tout article publié par *The Canadian Amateur* et déclarent en outre que toute expression d'opinion ou déclaration figurant dans un tel article représentent uniquement l'opinion de l'auteur dudit article et non l'opinion de la société Radio Amateurs du Canada Inc., ou celle de l'Éditeur ou du Rédacteur en Chef de la revue à moins qu'il soit spécifié que ce soit le cas en l'occurrence.

The Canadian Amateur est publié par la société Radio Amateurs du Canada Inc., 720 rue Belfast, Bureau 217, Ottawa, ON K1G 0Z5.

Enregistré à l'Index des publications canadiennes sous le numéro ISSN 0834-3977.

Accord de publications diffusées par courrier : 40028682.

Numéro de matricule 09866.

THE RAC QSL BUREAU SYSTEM

The RAC Outgoing QSL Bureau service is available to RAC members, RAC affiliated clubs (club call only) and QSL Managers who are members of RAC. Your RAC membership number must accompany each shipment of QSL cards.

RAC Outgoing QSL Bureau
PO Box 11156, Station H
Nepean, ON K2H 7T9
Telephone: 613-670-3230
Email: ve3exy@rac.ca

There are limits and restrictions for use of the Outgoing QSL Bureau. For more information, surcharges and card sorting details, visit <http://wp.rac.ca/> or <http://www.magma.ca/~ve3exy/bureau.html>.

The **Incoming QSL Bureau** service is a user-pay system, using one of four methods – (A) envelopes (B) credits (C) labels or (D) combination credit with labels – to get cards to you. For more information on the incoming system visit wp.rac.ca/. (***Note: Method B is preferred.**)

VE1 – VE0 Bureau (B)

Brit Fader Memorial QSL Bureau
Sponsored by the Halifax ARC
Tom Caithness, VE1GTC
PO Box 8895
Halifax, NS B3K 5M5

VE2 Bureau (A, B)*

Jacques Dubé, VE2KC
875 rue Sévère
Trois-Rivières, PQ G9A 4G4

VE3 Bureau (D)

QSL Manager
PO Box 216
Streetsville, ON L5M 2B8

VE4 Bureau (B)

Harm Hazeu, VE4HAZ
7 Ashley Cove
Winnipeg, MB R2G 2Z3

VA5/VE5 Bureau (B)

Todd Bendtsen, VE5MK
616 Moffet Drive
Weyburn, SK S4H 2M7

VE6/VA6 Bureau (B)

Larry Chapple VE6KC
208 Canterbury Place SW
Calgary, AB T2W 1P4

VA7/VE7 Bureau (B)

Ken Clarke, VE7BC
12441 – 58A Avenue
Surrey, BC V3X 1X6

VE8/VY0 Bureau (A, B)*

John Boudreau, VE8EV
PO Box 3099
Inuvik, NT X0E 0T0

VE9/VY2 Bureau (B)

Bob Sherwood Memorial QSL Bureau
Sponsored by the Moncton Area ARC
Wayne Gillcash, VE1RR
Box 73
Moncton, NB E1C 8R9

VO Bureau (B, C)*

Rick Burke, VO1SA
Box 23099, Churchill Square
St. John's, NL A1B 4J9

VY1 Bureau (A, B)

Hugh Henderson, VY1HH
Box 33062
Whitehorse, YT Y1A 5Y5

Silent Keys – In Memoriam

With regret, we record the passing of these Amateur Radio operators.

Nous avons le regret de vous annoncer le décès des radioamateurs suivants.

VA3GHB – George Buckrell, of Leamington, ON, at age 81, on April 10, 2015.
VA3LKH – John Hann, of Kitchener, ON, on February 29, 2015.
VA3NAZ – Wasi Naz, of Fort Erie, ON, at age 75, on January 15, 2015.
VA3POS – John Posthumis, of Welland, ON, at age 72, on January 21, 2015.
VA3WM – Willis McMullen, of Napanee, ON, at age 85, on March 3, 2015.
VA3WTA – Art Taylor, of Windsor, ON, at age 84, on May 7, 2015.
VA7IAM – Ian Victor (VA7IV), of Victoria, BC, at age 62, on December 26, 2014.
VA7KK – Bill Kathrein (VE7BSN), of New Westminster, BC, at age 68, on October 24, 2014.
VE1AHC – Georges-Emile Gagne, of Edmundston, NB, at age 73, on March 26, 2015.
VE1ALP – Rod Smith, of Dartmouth, NS, at age 83, on April 13, 2015.
VE1BJC – Barb Crandall, of Amherst, NS, at age 77, on May 16, 2015.
VE1BPG – Wilfrid Wile (VE1CT), of Bridgewater, NS, at age 87, on January 28, 2015.
VE1EF – Gerald Fraser, of Upper Musquodoboit, NS, at age 90, on March 8, 2015.
VE1HU – Claude Bailey, of Nasonworh, NB, at age 100, on March 26, 2015.
VE1KFW – Kevin Warham, of Truemanville, NS, at age 52, on December 16, 2014.
VE1LEN – Leonard Gentles, of Greenwood, NS, at age 72, on December 24, 2014.
VE1NPS – Nigel Service, of Williamswood, NS, at age 70, on January 27, 2015.
VE1PBS – Bruce Shipley, of Bear Point, NS, at age 65, on December 23, 2014.
VE1ROL – Rollie Smith, of New Germany, NS, at age 76, on February 6, 2015.
VE1RWR – Robert Burns, of Waterville, NS, at age 66, on March 25, 2015.
VE1XAM – Clarence Witherall (VE1CMW), of Lunenburg, NS, at age 80, on March 16, 2015.
VE2FYU – Ted Styrzczula, of Pierrefonds, QC, on November 29, 2015.
VE2KOK – Guy Sigman, of Sorel-Tracy, QC, at age 69, on March 31, 2015.
VE3BZT – John Ludwig, of Ancaster, ON, at age 69, on January 1, 2015.
VE3CAP – Don Wright, of Thunder Bay, ON, at age 69, on February 15, 2015.
VE3DS – L Eric Levison, of Brantford, ON, at age 85, on February 14, 2015.
VE3EAC – Derek Thompson, of Ottawa, ON, at age 90, on March 12, 2015.
VE3EEY – Ron Bailey, of Wellington, ON, at age 82, on April 30, 2015.
VE3FBH – Frank Baugh, of Camlachie, ON, at age 82, on April 1, 2015.
VE3FBQ – Norris McEwen, of Goderich, ON, at age 91, on January 26, 2015.
VE3FIO – John Micsinszki, of Windsor, ON, at age 85, on May 6, 2015.
VE3FUG – Lorne Fretz, of Selkirk, ON, at age 85, on January 4, 2015.
VE3FY – Allan Bonner, of York, ON, at age 86, on February 15, 2015.
VE3HPD – Vic Forde, of Hamilton, ON, at age 92, on April 21, 2015.
VE3JEC – Diesel Dutton, of Kingsbridge, ON, on February 21, 2015.
VE3MH – Keith Jones, of Ridgeway, ON, at age 89, on March 11, 2015.
VE3NV – Franc Somi, of Scarborough, ON, at age 96, on November 6, 2014.
VE3NYB – Ken Rowland, of St. Catharines, ON, at age 90, on December 31, 2014.
VE3NZL – Harold Tunnicliffe, of Peterborough, ON, at age 99, on January 12, 2015.
VE3TA – Paul Hudson, of Toronto, ON, on April 17, 2015.
VE3XOF – Fred Fox, of Scarborough, ON, at age 77, on February 18, 2015.
VE3ZXQ – Jim Heroux, of Oshawa, ON, at age 48, on May 14, 2015.
VE4LQ – Lawrence Patzel, of Winnipeg, MB, at age 89, on April 10, 2015.
VE4MAC – Ian Rollo, of Ottawa, ON, at age 88, on February 16, 2015.
VE5BCS – Harold Slack, of Christopher Lake, SK, at age 72, on April 27, 2015.
VE5IZ – Rudy Luukkonen, of Saskatoon, SK, at age 93, on April 13, 2015.
VE6HG – Bill Roberts, of Okotoks, AB, at age 89, on December 20, 2014.
VE6HS – Alexander Kachmar, of Edmonton, AB, on February 12, 2015.
VE6XM – Garth Doepel, of St Albert, SK, at age 82, on April 11, 2015.
VE6ZB – Chester Czarnecki, of Buck Lake, AB, on February 17, 2015.
VE7AN – Carl Tymm, of Penticton, BC, at age 83, on March 18, 2015.
VE7KVT – Nigel Smith-Gander, of Maple Ridge, BC, at age 78, on April 3, 2015.
VE7RRL – Bob Letts, of Williams Lake, BC, at age 82, on January 26, 2015.
VE7TRG – Terry George, of Chilliwack, BC, at age 62, on May 13, 2015.
VE9PBW – Percy Waddy, of Colpitts Settlement, NB, at age 92, on March 21, 2015.
VE9ST – Wayne Alexander, of Wilsons Beach, NB, at age 74, on February 19, 2015.
VO1FZ – Keith Perry, of Saint John's, NL, at age 58, on October 12, 2014.
VY1AU – Bill Champagne, of Whitehorse, YT, on March 31, 2015.

*Note: In the above list an * indicates that a call sign has been reissued. The list of Silent Keys is prepared by volunteers at RAC Headquarters. Please send obituary notices by email directly to rachq@rac.ca.*

RADIO AMATEURS OF CANADA / RADIO AMATEURS DU CANADA

NATIONAL EXECUTIVE



PRESIDENT
Geoff Bawden, VE4BAW
85 Barrington Avenue
Winnipeg, MB R2M 2A6
Tel. 204-257-1414
Email: ve4baw@rac.ca
Note: please copy racgm@rac.ca on all emails to VE4BAW.

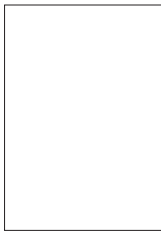

VICE-PRESIDENT
Vacant



CHIEF INFORMATION AND TECHNOLOGY OFFICER
Paul Burggraaf, VO1PRB
51 Greenspond Drive
St. John's, NL A1E 5Z9
Tel. 709-745-1999
Email: vo1prb@rac.ca



ATLANTIC
Everett Price, VO1DK
6 Virginia Road
St John's, NL A1A 3A8
Tel. 709-738-3508
Email: vo1dk@rac.ca



MIDWEST
Derek Hay, VE4HAY
51 St. Hilaire Place
Winnipeg MB R2J 4B5
Tel. 204-257-1420
Email: ve4hay@rac.ca

DEPUTY DIRECTORS

ATLANTIC
Len Morgan, VE9MY
QUEBEC
Normand Pitre, VE2NHN

ASSISTANT DIRECTORS

ALBERTA / NT / NU
Chris Cameron, VE8WD
Wally Gardiner, VE6BGL
Neal Sunderland, VA6NLS
Bill Tiil, VE5FN

ATLANTIC
Rino Deschenes, VE9VIC
(North-Western NB)
Sheldon Donaldson, VE1AR9
(Yarmouth-Shelburne area)

Jim Fisher, VE1JF
(Annapolis Valley / Fundy Shore)
Bill Glydon, VY2LI
(Western PEI)

David Hildebrand, VE9AV
(Fredericton and area)
Terry MacInnis, VO1TJM
(NL West Coast)

Marc Morel, VE1MAM
(Edmundston, NB)
Vince O'Keefe, VO1SO
(Avalon Peninsula)

Francis Pitre, VE9FCP
(Acadie-Bathurst area)
Naz Simon, VO2NS
(Labrador)

Peter Surette, VE1PJS
(Truro and area)
Scott Wood, VE1QD
(Halifax and area)

BRITISH COLUMBIA / YUKON

Lou Beaubien, VE7CGE
(Burnaby, BC)
Carl Bertholm, VE7CLC
(Kelowna, BC)

Eric Manning, VA7DZ
(Vancouver Island)
Ron McFadyen, VY1RM
(Whitehorse, YT)

Frank Merritt, VE7FPM
(Nanaimo, BC)
Al Munnik, VE7RMP
Langley, BC

Richard Thompson, VE7XT
(Victoria, BC)
Ross Wilmot, VA7NRW
(Surrey, BC)

MIDWEST
Richard Holder, VE4QK
Doug Pfaff, VE5DCP
Bill Tiil, VE5FN

ONTARIO NORTH/EAST
Allan C. (Al) Boyd, VE3AJB
Paul Caccamo, VA3PC
Dave Hayes, VE3JX
Dan Howard, VA3MA
Don Tambeau, VE3HOL

ONTARIO SOUTH
Keith Baker, VA3KSF
(Sarnia)
Jerry Beneteau, VE3EXT
(Essex & Kent)

Doug Campbell, VA3DC
(Simcoe)
Doug Frame, VE3JDF
(Niagara)

Stan Leschinsky, VE3TW
(Greater Toronto Area)
Gordon Moogk, VE3DBP
(Grey-Bruce)



INTERNATIONAL AFFAIRS OFFICER
George Gorsline, VE3YV
118 MacPherson Avenue
Toronto, ON M5R 1W8
Tel. 416-921-4214
Email: ve3yv@rac.ca



CHIEF FIELD SERVICES OFFICER
William (Bill) Boskwick,
VE4BOZ/VE4IR
PO Box 411
Elm Creek, MB R0G 0N0
Tel. 204-436-3523
Email: ve4boz@rac.ca



HONOURARY LEGAL COUNSEL
Marcel D. Mongeon, VA3DDD
Suite 374
3-35 Stone Church Road
Ancaster ON L9K 1S4
Tel. 905-390-1818
Email: va3ddd@rac.ca



ALBERTA/NWT/NU
J.T. (Mitch) Mitchell, VE6OH
10438-139 Street
Edmonton, AB T5N 2K5
Tel. 780-446-8958
Email: ve6oh@rac.ca



ONTARIO NORTH/EAST
Glenn MacDonell, VE3XRA
2047 Chalmers Road
Ottawa, ON K1H 6K4
Tel. 613-523-4333
Email: ve3xra@rac.ca

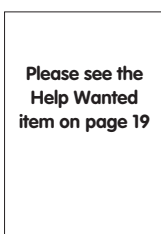

CORPORATE SECRETARY
Vacant



TREASURER
Dorothy Brown, VA7DBR
12542 24A Avenue
Surrey, BC V4A 8H9
Email: dorothyebrown@shaw.ca



BRITISH COLUMBIA/YUKON
William (Bill) Gipps,
VE7ISV/VE7XS
9362 - 206A Street
Langley, BC V1M 2W6
Tel. 604-328-0111 Mobile
Email: Bill.Gipps@gmail.com

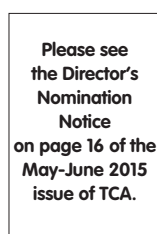

ONTARIO SOUTH
Vacant



RAC SECTION MANAGERS

ALBERTA

Garry Jacobs, VE6CIA
45 Selkirk Boulevard
Red Deer, AB T4N 0G4
ve6cia@rac.ca

BRITISH COLUMBIA/YUKON

Vacant
Acting: Bill Gipps, VE7XS
9362 - 206A Street
Langley, BC V1M 2W6
Bill.Gipps@gmail.com

MANITOBA

Jan Schippers, VE4JS
202 Sadler Avenue
Winnipeg, MB R2M 1P3
ve4js@rac.ca

MARITIMES

Craig Seaboyer, VE1DSS
136 Ohio Lake Road, RR 1
Antigonish, NS B2G 2K8
cseaboys@stfx.ca

NEWFOUNDLAND-LABRADOR

Vacant

ONTARIO NORTH

Allan Boyd, VE3AJB
27 Red Mill Road, Box 208
Little Current, ON POP 1K0
ve3ajb@vianet.ca

ONTARIO SOUTH

Allan Foley, VE3XAL
9 Cutter Circle, RR1
New Lowell, ON, L0M 1N0
ve3xal@rac.ca

ONTARIO EAST

Michael Hickey, VE3IPC
2768 Chartrand Road
Lafaire, ON K0B 1J0
ve3ipc@gmail.com

ONTARIO GTA

Vacant
Acting: Allan Boyd, VE3AJB
27 Red Mill Road, Box 208
Little Current, ON POP 1K0
ve3ajb@vianet.ca

QUEBEC

Vacant

SASKATCHEWAN

Vacant

For complete Section Reports please see the Section News on page 60 and the Public Service/ARES column on page 46.



QUEBEC
Sheldon Werner, VA2SH/VA6SH
4225 Place Sainte-Helene
Laval, QC H7W 1P3
Tel. 450-682-0829
Email: va2sh@rac.ca

Feedback: Readers write to The Canadian Amateur

KINDRED SPIRITS: "MAKERS"

I have been delving into a world of kindred spirits. These are the "makers". Banding together, creating workshops and meeting places, they are applying their hearts, brains and hands to creating useful objects while sharing the joys of doing so.

This sounds familiar to hams and especially the lucky ones who are members of vibrant clubs.

I wondered if there might be an intersection of makers and hams. Reading the ham mags over the past couple of years, I noticed rising and falling interest in the Maker Movement by the two major USA publications. Could it be that makers are local, rather than national, in outlook ("...act local, think global")?

If local action is key, perhaps Canadian hams and clubs might like to know about maker groups in their areas. A representative list of Canadian maker organizations is shown below. Perhaps exciting linkages might be made benefiting both hams and makers!

Bill Karle, VE1YY – Lantz, Nova Scotia

THE MAKER MOVEMENT	
Organization	Website
Halifax Makerspace	http://halifaxmakerspace.org
Ottawa MakerSpace North	http://makerspacenorth.com/ - nav-home
University of Ottawa, Faculty of Engineering MakerSpace	http://engineering.uottawa.ca/makerspace
Montreal FouLab	http://foulab.org/en/wiki/Index_Page
Toronto MakerKids	http://www.makerkids.com
Toronto Icewire	http://make.icewire.ca
Toronto Site3	http://www.site3.ca
Toronto Public Library Makerspace	http://torontotoollibrary.com/makerspace/
Thunder Bay OhmBase	http://www.ohmbase.org
Winnipeg Assent Works	http://assentworks.ca
Regina Crash Bang Labs	http://crashbanglabs.org
Regina Public Library	http://www.reginalibrary.ca/maker/
Saskatoon Sketchworks	http://www.sktechworks.ca
Calgary MakerSpace	http://www.calgarymakerspace.com
Calgary ProtoSpace	http://www.protospace.ca
Edmonton Public Library MakerSpace	http://www.epl.ca/makerspace
Edmonton New Technology Society	http://www.ents.ca/index.php/Main_Page
Whistler MakerSpace	http://whistlermakerspace.org
Victoria MakerSpace	http://www.makerspace.ca

AN "EXTRA SPECIAL" TCA

I really liked the March-April QRP issue! The techniques, skills and attention to equipment to squeeze as much as possible out of QRP are transferable to and improve one's usual operation as well.

Special thanks to the RAC Board and National Executive for allowing the extra expense for higher quality print production this time around as well. It really is appreciated and makes the issue "extra special".

I am looking forward to the next "Special Issue" TCA.

Bill Henderson, VA3HWA – Nepean, Ontario

WWW.
HAMSTUDY
.COM

Self study courses for Canadian
BASIC and ADVANCED
Amateur Radio exams

FREQUENCY ALLOCATIONS

Please thank Bryan Rawlings, VE3QN, for his educational report on Amateur Radio frequency allocation requests ("An Amateur Radio Approach to Spectrum Sharing Studies," November-December 2014).

It reminds me of the time I spent in the Signal School in Kingston, Ontario working with the staff of the Transmitter Building.

The building contained several high-power MF and HF transmitters and associated antenna systems hung on 110-foot towers.

We ran continuous RY tapes on training frequencies to protect those allocations from takeover by other nations, who would try to collect non-use data in justification for their demands.

The government's reduction of the Canadian Forces in the mid-late 1960s meant that fewer trainers were available within the School, which caused reduction of the Transmitter Building staff to one senior non-commissioned officer (NCO).

The high voltages and RF energy in the building made it unsafe for one man to remain there alone so the station was closed down when no classes were being conducted. The frequencies were quickly snapped up by a certain monitoring nation.

I hope adequate staff have been restored to that resource, but it may be a case of closing the barn door after the horse was gone.

Charles Hooker, VE3CQH
East Garafraxa, Ontario

A MESSAGE FROM THE PRESIDENT / UN MESSAGE DU PRÉSIDENT



Geoff Bawden, VE4BAW
204-257-1414
ve4baw@rac.ca

RAC IS OUT AND ABOUT...

In May, RAC Directors and Executive held a planning meeting in southern Ontario which was accompanied by a public meeting where RAC volunteers made presentations.

We used our Internet platform to bring in speakers from coast to coast: RAC volunteers working on files

ranging from the Field organization, our contests, the RAC Insurance Program, ARISS and more. We will be doing the same at our Annual General Meeting on July 4 in Saskatchewan (see page 10). Watch Facebook and our website for more information.

We presented an Excellence in Service Award to Ian MacFarquhar, VE9IM. Ian has been a pillar of RAC for decades and served as Vice-President through many RAC Presidents. He also served as Acting President on a number of key occasions and during some tough times.

I am pleased to say that for the fourth year in a row RAC is in the black. The summary of the audit report will be posted on our website and will be published in the September-October 2015 TCA along with the Minutes of the Annual General Meeting.

We have stopped supporting two websites. It was much too distracting and resource intensive to maintain two of them. The old one was technologically obsolete and difficult to maintain, but it served us well while we were creating the new RAC website. We received very few comments about the new site before we shut down the old one, but we have now received both praise and constructive comments about the new site. We will continue our work on the site to make it the centre of our communications strategy. I would like to thank Paul Burggraaf, VO1PRB, RAC Chief Information and Technology Officer, for all of his hard work.

We want to profile our scholarship and grant program. Every year, we provide funds to worthy community programs and Amateurs who seek education in the technologies related to radio. RAC has provided community funds to Shaftesbury High School in Winnipeg, Manitoba. Teachers there have earned their Amateur certification and ensured that students had the Amateur Radio certification in order to track balloons by APRS to the edge of space. They have also built a telebridge, Canada's first, to permit not just students at Shaftesbury High School, but also students across Canada and beyond to talk to the International Space Station (see page 51).

For more information on how to provide funds for our scholarships and community grant program or to apply for a scholarship or grant, please contact Bill Unger, VE3XT, at ve3xt@rac.ca.

Geoff Bawden, VE4BAW
RAC President and Chair

RAC EST À PIED D'OEUVRE...

En mai, les directeurs et les membres de l'Exécutif ont tenu une réunion de planification dans le sud de l'Ontario en même temps qu'une assemblée publique au cours de laquelle les bénévoles ont pris la parole.

Nous avons utilisé notre plateforme Internet pour les joindre et parler avec eux d'un océan à l'autre : les bénévoles de RAC travaillant dans tous les services, l'Organisation sur le terrain, nos concours, notre programme d'assurance, ARISS et plus encore.

Nous ferons de même à notre assemblée générale annuelle le 4 juillet, en Saskatchewan (voir page 10). Surveillez Facebook et notre site web pour plus d'informations.

Nous présentons un prix d'excellence à Ian MacFarquhar, VE9IM pour les services rendus à RAC. Ian a été un pilier de RAC pendant des décennies à titre de vice-président sous plusieurs présidents. Il a aussi agi à titre de président en plusieurs occasions importantes et durant des périodes difficiles.

Je suis heureux de dire que les quatre derniers exercices financiers de RAC ont été écrits à l'encre noire. Le résumé du rapport de vérification sera affiché sur notre site web et publié dans le TCA de septembre-octobre 2015, en même temps que le procès verbal de l'Assemblée générale annuelle.

Nous avons cessé de soutenir deux sites web. Cela devenait trop exigeant et demandait trop de ressources. L'ancien était devenu obsolète et trop difficile à garder à niveau; mais ils nous a été d'une grande utilité pour la création du nouveau site de RAC. Nous avons reçu peu de commentaires à propos du nouveau site avant de réduire l'ancien au silence. C'est maintenant que nous en recevons à propos de notre nouveau site, et ils sont constructifs et messages de félicitation. Nous poursuivons notre travail sur le site afin d'en faire notre centre stratégique des communications. J'aimerais remercier Paul Burggraaf, VO1PRB, responsable en chef de l'information et de la technologie, pour tout ce travail laborieux.

Nous désirons vous donner un aperçu de notre programme de bourses. Chaque année, nous versons des subventions pour des programmes d'aide utiles à la communauté et bénéficiant à des amateurs qui poursuivent des études en technologie radio. RAC a versé des fonds communautaire au Shaftesbury High School à Winnipeg, Manitoba, en raison de professeurs qui ont obtenu leur certification et assurés que des étudiants reçoivent aussi la leur dans le but de poursuivre des balons par APRS jusqu'à la limite de l'espace. Ils ont aussi construit un télébridge, le premier au Canada, afin de permettre aux étudiants de partout au Canada et au-delà, pas seulement les étudiants de Shaftesbury High School, de parler avec la station internationale (see page 51).

Pour plus d'informations sur la collecte de fonds pour nos bourses d'études et subventions communautaires ou pour appliquer pour ces bourses, s.v.p. communiquez avec Bill Unger, VE3XT, ve3xt@rac.ca.

Geoff Bawden, VE4BAW
RAC Président-directeur général

— Traduction par Claude Lalonde, VE2LCF. Merci Claude!



AROUND THE CORNER...

People, Places, News and Events on the Canadian Amateur Radio Scene

RAC Section Manager Appointed for Ontario South

I am pleased to announce that Allan Foley, VE3XAL, of New Lowell, Ontario has accepted his appointment as the Radio Amateurs Canada Section Manager for Ontario South, effective immediately.

Al has been an Amateur Radio operator for more than 25 years and has been active and involved in Amateur Radio community service, emergency planning and had attended the Canadian Emergency Preparedness College in Arnprior, Ontario.

Al has spent many years at various locations throughout Ontario with his work in the Ministry of National Resources. Allan and his family live in New Lowell and compete with each other to "control the mike" in their ham shack. Al's wife Peggy, VE3PGY and son Don, VE3DZA, are also Amateur Radio operators.

RAC welcomes Allan aboard and is confident that he will bring positive things both to his Section and to RAC Field Operations.

Allan may be contacted at ve3xal@rac.ca or at 705-424-7424.

*Bill Boskwick (CEC), VE4BOZ
RAC Chief Field Service Officer*

New RAC Website

We have officially cut over to our WordPress-based Radio Amateurs of Canada website. This site can be accessed via wp.rac.ca or www.rac.ca. The old site will no longer be available.

Please ensure you login with your call sign and password (Associate Members use their membership number). There is an option to reset your password below the login screen. The math question is a security requirement to ensure human input and not a robot program trying to hack your password.

We are still moving content over from the old site as required. If there is a particular article from the old site that you cannot locate, please email the webmaster and we will endeavour to port that content over to the new site.

In the coming weeks we will be changing the URL to www.rac.ca and launching further enhancements to the site.

*Paul Burggraaf, VO1PRB
RAC Chief Information and
Technology Officer*

Nouveau site de RAC

Officiellement, nous avons réduit la dimension du site web attaché au WordPress de Radio Amateurs du Canada. Ce site est accessible via wp.rac.ca ou www.rac.ca. L'ancien site ne sera plus accessible.

Veillez s.v.p. vous assurer que vous utilisez votre indicative d'appel et votre mot de passé pour vous connecter (Les membres associés utiliseront leur numéro de membre). Vous pouvez vérifier votre mot de passe sous la fenêtre de connexion. L'énigme (math question) est conçu pour assurer que la demande est faite par une personne et non par un programme robot cherchant à s'emparer de votre mot de passe.

Nous poursuivrons le déménagement du contenu de notre ancien site selon le besoin. S'il devait y avoir un article particulier dans l'ancien site que vous ne pouvez trouver, s.v.p. envoyez un courriel au webmestre et nous verrons à vous transférer au bon endroit sur le nouveau site.

Dans les semaines à venir nous changerons l'URL à www.rac.ca et renforcerons le contenu du site.

*Paul Burggraaf, VO1PRB
Responsable en chef de l'information et
de la technologie*

RAC Comments on ARRL Proposed Changes to US HF Band Plans

The American Radio Relay League (ARRL) published proposed changes to the US HF band plan for comment in the April edition of *QST*. Being proactive, the RAC Band Planning Committee reviewed their proposals for potential impacts on Canadian Amateurs.

Most of the proposed ARRL changes increase the sub-bands allocated to digital operations by extending the existing frequency limits upwards into band segments usually used for phone communications outside the US.

While the RAC Band Planning Committee understands and supports the ARRL's goal to provide additional space to accommodate the growth in digital modes, the proposed changes will have unintended consequences.

As Canadian phone operations in the 80m and 40m bands take place primarily below the current US phone sub-bands to minimize mutual interference, the effect of the proposed changes would be to reduce the space available to

Canadian Amateurs. On 40m and 20m, the proposed changes would also negatively impact DX phone operations throughout the Americas, and the rest of the world.

RAC has formally communicated our concerns to the ARRL with the request that they include these concerns in their consideration of any changes to the US sub-bands.

*George Gorsline, VE3YV
RAC International Affairs Officer*

Commentaires de RAC à propos des changements au plan de bandes HF des É.-U. proposés par l'ARRL

L'American Radio Relay League (ARRL) a rendu public les changements proposés au plan des bandes HF des É.-U. dans le but d'obtenir des commentaires qu'elle publiera dans le *QST* d'avril. Par cette pro-activité, le comité de planification des bandes de RAC a révisé ses propositions, considérant l'impact potentiel sur les besoins des amateurs canadiens.

La plupart des changements proposés par l'ARRL sont à l'effet d'augmenter l'espace des sous-bandes (sub-bands) allouées aux opérations numériques et ce, en repoussant les limites des fréquences existantes vers des segments de bande habituellement utilisés pour les communications téléphoniques à l'extérieur des É.-U.

Pendant que le comité de planification des bandes de RAC accepte et soutient l'objectif de ARRL d'offrir plus d'espace pour répondre au besoin croissant des modes digitaux, les changements proposés ne seront pas sans conséquences.

Du fait que les activités du téléphone canadien se situent surtout à l'intérieur des bandes du 80m et 40m sous les sous-bandes actuelles du téléphone aux É.-U., pour minimiser les interférences mutuelles, l'effet des changements proposés sera de réduire l'espace disponible pour les amateurs canadiens. En ce qui concerne les 40m et 20m, les changements proposés auront un impact négatif sur les opérations téléphoniques DX à travers les Amériques et le reste du monde.

RAC a officiellement communiqué nos problématiques à l'ARRL dans l'espoir qu'elle tiendra compte, dans leurs considérations, de tous changements apportés aux sous-bandes des É.-U.

*George Gorsline, VE3YV
Responsable des affaires internationales
de RAC*





Dana Shtun, VE3DS
14 Ashwood Crescent
Toronto, ON M9A 1Z3
E: ve3dss@rac.ca
W: www.qsl.net/ve3dss

SIX METRES AND DOWN

“TRANSATLANTIC TROPO OPENING!...”

The main thing with these and any contest is activity, and propagation.

Now propagation is dependent on your location, weather conditions, solar conditions and luck. Activity on the other hand can be driven by your buddies all getting on. For example, in your local club there may be a few guys with 432 MHz SSB capability and a lot more with 440 MHz FM capability so why not get them on simplex and work them as part of your contest activity – that way everyone is included, your score will grow and you might just get a few more people interested in activity at 432 MHz on SSB or CW or WSJT.

Here’s another list of contests, as shown in my last column.

CQ World Wide VHF: begins 1800 UTC Saturday July 18 and ends 2100 UTC Sunday July 19. This contest is for 50 and 144 MHz only. As 50 and 144 MHz are in essence “entry” bands for the VHF and Up world, CQ wants to include as many people as possible around the world to fire up from home, get out on a hilltop in the car or tent and make some noise. Try it folks!

At the other end, the ARRL UHF Contest is set for August 1 and 2. The contest starts at 1800 UTC on Saturday, August 1 and ends on Sunday August 2 at 1800 UTC. This contest is a 222 and Up contest so the object is to get on the higher bands and work as many 2 x 1 degree grid squares as possible. Point scores vary as well: 222 and 432 count 3 points; 902 and 1296 count 6 points; and 2304 and up count 12 points! So you can see that every 2304 contact is like 4 on 432 MHz – that’s an incentive to hit the higher bands.

In addition, the Microwave Contest caters to 10 GHz and up and is a two-weekend affair with Part 1 running on August 15 and 16. Part 2 runs on September 19 and 20. Operations allow for a 24-hour total operating time between local time 6 am Saturday and 12 midnight on Sunday. This contest is attractive for DXing using portable gear and groups go out and operate together from various high hills, lake shores, ocean vantage points, or what have you. Some extraordinary distances have been worked during this contest.

Finally, the ARRL Fall VHF QSO Party ARRL is set for September 12 to 14. The contest starts at 1800 UTC Saturday and ends on Monday, September 14 at 0259 UTC. There is potential for long-haul tropo contacts in the east – coastal

propagation between Florida and Nova Scotia, or Montreal to St. Louis or even Toronto to Miami – so not only should you get your club on for contacts but you should also look for DX.

SPRING SPRINTS REPORT

This spring we managed to get into some of the VHF/UHF sprints and had some fun running low power. Weather conditions were changeable and the 144 MHz sprint was a bit tough with high winds and rain. Conditions were similar for 222 MHz with storms and cold, but we were able to snag VE3OIL/R, VE3FN in Ottawa, VE2DSB, K1WHS, K1TEO, and K9MRI to the west. The 432 sprint was much better for propagation and we were able to work out west to K9MRI, as well as down into WB2RVX in FM29 and east to K1TEO (FN31), K1DS(FN20) and K1RZ (FM19) and AI VA3AM in FN03!

Lots of VE activity was noted Congrats to VE3ZV, VE3CRU/R, VE3OIL/R, VA3ELE, VA3ZV, VE3FN(FN25) VE2DFO(FN25), VE2DSB(FN25), VE2XX(FN25) and others for getting on and making lots of QSOs.

Sprints are little mini contests that run between 7 pm and 11 pm local time.

Next opportunity will be the Fall Sprints; hopefully we will get some fair weather for them.

The Fall Sprint dates are as follows:

September 21: 144 MHz

September 29: 222 MHz

October 7: 432 MHz

October 17: 902 and Up Microwaves

SIX METRE SPORADIC E ACTIVITY

April 16 brought a strong Auroral opening with Ed, VE3KRP, in Thunder Bay starting off the action followed by W9EWZ, VE2XK, VE2ZT, WA1T, VE2DXG, N8BJQ, N8CX, K9IMM and W3EP worked. Solar flux was 150, A43 and K6 with severe solar storm conditions – although not quite up to the Great St. Patrick’s Day solar storm conditions, hi.

April was an interesting month on 50 MHz TEP (trans-equatorial propagation), with some teasing of DX including an opening on April 20, with CX90IARU worked at 2022. Unfortunately, it was one of those “toe print” openings with no one else worked.

Then on April 26 the band opened again strongly with CX90IARU worked with 599 signals both ways, followed by CX7BBB, LU9AEA, LU8ADX and LU6DRV – all between 1952 and 2022 UT. Sadly, nothing was heard from ZP or CP call areas.

Reports are in of a tropo opening spanning the Atlantic between Bonaire and Cape Verde Islands. The beacon, on 144.436 MHz with call D4C/B in grid HK76mw, was copied by PJ4VHF on May 6. The distance is roughly 4,686 kilometres!

Apparently the beacon was heard for 90 minutes between 0100 and 0230 with signals running 519. PJ4VHF uses a pair of 13-element yagis and at TS-2000.

If you want to see more info, go to [https://www.facebook.com D4C.STATION](https://www.facebook.com/D4C.STATION)

In addition, D44TD is QRV on 144 MHz from HK86no and looking for contacts on Atlantic Tropo. So if you live on the east coast, take a listen down that way on 144 MHz. Incidentally, EI3KD has heard the beacon as well! The D4C site in addition is awesome!

Hopefully, we will see a contact with live operators at each end this summer.

SUMMER/ FALL CONTESTS

Contests on 50 MHz and up can be pretty interesting and challenging.

During the summer months there are a few that cater to the higher bands only as well as our VHF bands.

The traditional Sporadic E season has been off to a slow start but, as each day advances through May, the openings are becoming more frequent.

May 17, brought VE7DAY a lot of north-south DX into DM13, DM34, DM03, DM27 with 11 stations worked. John listened for the JAs but to no avail. They were being heard in Alaska though.

May 27 brought a double-hop opening from VA7FC into the US.

On May 28, John, VE7DAY, worked W3EP at 0101 in FN31 with 579 signals and W9MAF at 0232 UTC. In addition, the JAs were being heard on the west coast and worked by some of the W6 gang.

Hopefully, we will see some transatlantic DX this summer to go with some multihop DX into Europe – fingers crossed.

1296 MHz ACTIVITY

Peter, VA3ELE, has started a 1296 group on Facebook and a local net every Thursday night at 9:30 pm. Checkins have ranged from across Lake Ontario, up to Georgetown and around the GTA. If you have 1296 gear give a listen on 1296.1 MHz, and join the group!

VE3DS STATION AUTOMATION

Finally, after much perseverance, I can say goodbye to the rats nest of wires and cables in my VHF/UHF station.

I had seen some articles in *QST* back in 2008 about a control system for VHF/UHF ops and filed it away as a “nice to have one day” thing. Having bought a K3 in 2011, I was struggling to mate up all my transverters and amps with it. I had read about a slick automation system developed by Terry, W8ZN, in *QST* from 2008 and had filed the article away. I got in touch with Terry to see if he had any more boards and, thankfully, he did and we were able to get one from him. In addition Dave, G4FRE/WW2R, had a small board that talked to the K3 on the RS-232 line, with a nice display that also provide per band PTT outputs, and we were able to pick one of these up from Dave.

Fortunately, a trip to Dayton in 2014 was just what I needed to pick up a lot of that hardware and a Down East Microwave 4-port sequencer was picked up at Microwave Update in October.

With all that in hand I then began integrating everything but there were some glitches. Terry’s board wouldn’t switch via the Accessory port on the K3 as Elecraft had made design changes. That problem was resolved with a lot of reading and then some integrated circuit (IC) changes. Then the on board relays wouldn’t pick. It turned out Terry had a batch of polarized relays – with the coil polarity opposite to the board – so that got fixed.

I then decided to change everything over to 24 volts and solved that with 24-volt OMRON relays from Digikey. The other problem was finding a Hammond box that would contain all the various boards – plus power supplies and four rotary relays – but that was solved and the metal bashing started.



I’ve been worked away on this little project for 18 months and solving problems as I go along. It’s been a learning experience getting to understand the data coming out of the K3 and figuring out how to route the information from the K3 to the controller, and to the PC for logging and JT, doing metal work, wiring up the controller boards, the rotary relays and so on.

Now all I need to do is push the “Band” button on the K3 and I can switch between HF, 50, 144, 222, 432, 902 and 1296 MHz (and 2304 eventually).

The above photo shows the rack with the microwave transverters on the top, the controller in the middle, and the 222 and 432 transverters and 222 amplifier at the bottom. I still have more work to do but it’s looking much tidier.

I still don’t know why they call this hobby “wireless”, but it sure is fun!

ANTENNA’S AND TRANSVERTER SOURCES

Terry, W8ZN, by the way is the owner of Directive Systems. If you are looking for antenna products for 50 to 5760 MHz such as K1FO Yagis or Loop Yagis, drop in to Terry’s site at: <http://directivesystems.com>. You won’t be disappointed!

Also, if you are looking for transverters or preamplifiers a good source is Downeast Microwave, operated by Steve, N2CEI/4: <http://www.downeastmicrowave.com>

In addition there are a number of other people selling transverter kits and complete units including:

- Elecraft: <http://www.elecraft.com/>
- W1GHZ: http://www.w1ghz.org/small_proj/small_proj.htm
- SignalBlox: http://www.signalblox.com/Home_Page.php
- eBay (from the Ukraine): <http://tinyurl.com/prb3azx>

HackRF

With all this going on I did not have time to try out the HackRF on 2304 MHz, but hopefully when I do I will get it going in more than just beacon mode. This technology will eventually make this whole rack of stuff, with all my automation, obsolete and reduce it to a couple of small boxes plugged into a laptop – and we are not talking microwatts either.

With the availability of devices that cover 500 MHz to 3 GHz at 100 watts output, a high power pure SDR station in a box becomes closer to reality.

Check out Digi-Key Electronics at: <http://www.digikey.ca/product-search/en?mpart=CGHV40100F&v=90>

So that’s it for now. Have a great summer and send us some reports and pictures of your summer VHF/UHF Microwave activities to share with everyone!

– 73, Dana, VE3DS



ANNUAL GENERAL MEETING RADIO AMATEURS OF CANADA INC.



The Radio Amateurs of Canada is pleased to hold its Annual General Meeting (AGM) in Martensville, Saskatchewan. The AGM event will be hosted by the Meewasin Amateur Radio Society and will be held in conjunction with the 2015 Saskatchewan Hamfest which is being held at the same location. All RAC members are encouraged to attend the Annual General Meeting.

Date: Saturday, July 4, 2015

Time: 10:30 am (Central Standard Time)

Place: The Annual General Meeting will be held at the Northridge Community Centre, 901 3rd Street North, Martensville, Saskatchewan (see below for more information).

Agenda items will include:

- Report of the President
- Review of the 2014 finances
- Appointment of auditors for 2015

A Question and Answer period will follow the AGM proceedings.

This is your opportunity to hear what your representatives have been doing over the past year, to raise questions, and to make suggestions about how RAC is managed and where it is going in the future.

The meeting will be attended by some of the members of the RAC Board of Directors and Executive and is open to all RAC members. In addition there will be a planned Webinar which RAC members can attend remotely.

For more information about the 2015 Saskatchewan Hamfest please see the article below or visit:
<http://www.meewasin-ars.ca/>

2015 SASKATCHEWAN HAMFEST



The Meewasin Amateur Radio Society is pleased to host the Annual General Meeting of Radio Amateurs of Canada in conjunction with the annual Saskatchewan Hamfest. The Saskatchewan Hamfest will be held as a three-day event from July 3 to 5.

Place: Northridge Community Centre, 901 3rd Street North, Martensville, Saskatchewan (9 kilometres north of Saskatoon on Highway 12)

The schedule for the Hamfest is as follows:

Friday: The registration and a Meet & Greet will be held at 6 pm.

Saturday: The fleamarket opens to the public at 9 am. Vendors can set up at 8 am. All tables must be reserved ahead of time.

Sunday: The doors to the event will open at 8 am.

Cost: The admission to the fleamarket is \$25 per person (in advance) for all three days. Tables cost \$10 each. There is a limited amount of tables and they are on a first come, first served basis.

Talkin: VE5CC Repeater 146.970 (-600) 100.0 Hz Tone or the VA5DR Repeater 448.125 (-5M) D-STAR.

Please visit the club's website for updated information at:
<http://www.meewasin-ars.ca/>

ASSEMBLÉE GÉNÉRALE ANNUELLE RADIO AMATEURS DU CANADA INC.

Radio Amateurs du Canada est heureux de tenir son Assemblée générale annuelle (AGM) à Martensville, Saskatchewan. L'hôte de l'AGM est la Meewasin Amateur Radio Society qui organisera l'événement en collaboration avec le Hamfest 2015 de la Saskatchewan lequel se tiendra au même endroit. Tous les membres de RAC sont invités à participer à l'Assemblée générale annuelle.

Date : samedi, le 4 juillet 2015

Heure : 10h30 (heure normale centrale)

Lieu : l'Assemblée générale annuelle se tiendra au Northridge Community Centre, 901, 3^{ème} rue nord, Martensville, Saskatchewan (voir ci-dessous pour plus d'informations).

L'ordre du jour inclura :

- le rapport du président;
- la revue des états financiers de 2014
- la nomination du vérificateur pour 2015

Une période de questions et réponses suivra les activités de l'AGM.

Voici votre chance d'entendre vos représentants vous dire ce qu'ils ont accompli au cours de l'année dernière, poser des questions, faire des suggestions sur la gestion de RAC et connaître ses intentions futures.

Plusieurs membres du Conseil d'administration et de l'Exécutif de RAC participeront à l'Assemblée, à laquelle tous les membres de RAC sont bienvenus. De plus, des membres de RAC pourront participer à l'assemblée à distance au moyen d'un Webinar prévu à cet effet.

Pour plus d'informations sur le Hamfest 2015 de la Saskatchewan, s'il vous plaît voir l'article ci-dessous ou visiter:
<http://www.meewasin-ars.ca/>

LE HAMFEST 2015 DE LA SASKATCHEWAN

La Meewasin Amateur Radio Society est heureuse d'accueillir l'Assemblée générale annuelle de Radio Amateurs du Canada en collaboration avec le Hamfest annuel de la Saskatchewan. Le hamfest durera trois jours, du 3 au 5 juillet.

Lieu : Northridge Community Centre, 901 3^{ème} rue nord, Martensville, Saskatchewan (9 kilomètres au nord de Saskatoon en bordure de l'autoroute 12)

L'agenda du hamfest est comme suit :

Vendredi : enregistrement, accueil et rencontre à 18h00.

Samedi : le marché aux puces ouvre ses portes au public à 9h00. Les vendeurs peuvent entrer et s'installer à partir de 8h00. Toutes les tables doivent être réservées à l'avance.

Dimanche : les portes ouvrent à 8h00.

Coût : L'admission au marché aux puces est de 25 \$ par personne (payable d'avance) pour les trois jours. Les tables sont au coût de 10 \$ chacune. Le nombre de tables est limité et la règle du premier arrivé, premier servi prévaudra.

Contacts radio : répéteur VE5CC à 146.970 (-600) tonalité 100.0 Hz ou répéteur VA5DR à 448.125 (-5M) D-STAR.

Veillez, s.v.p. visitez le site web du club pour les dernières informations : <http://www.meewasin-ars.ca/>

– Traduction par Claude Lalande, VE2LCF –

Easy-to-Build VHF Yagis

Steve Kavanagh, VE3SMA

INTRODUCTION

This article describes a simple way to build Yagi antennas for VHF and UHF, and gives dimensions for two proven designs for the 222 MHz band. I've also used the same construction technique (with slightly larger diameter elements) at 144 MHz with good results.

This all started when I was looking for a better antenna than the 6-element W2PV-style Yagi I was using for 222 MHz SSB/CW operation. After a bunch of portable operation it was getting pretty bent up!

Note: For more information see Dr. James L. Lawson, W2PV, Yagi Antenna Design, ARRL, Newington CT, 1986.

I looked at WA5VJB's excellent wood boom "Cheap Yagi" designs (<http://www.wa5vjb.com/yagi-pdf/cheapyagi.pdf>), but none really fit my needs exactly so I looked at using a computer model to modify his designs, and found that his "hairpin" partly folded dipole driven elements were probably going to be hard to model accurately.

I then realized an ordinary split-in-the-middle dipole could be made in two halves, mounted in slightly offset holes in a wooden boom as shown in Figure 1. I thought I could model this well enough on the computer. Yagi designs with 50 ohm direct feed are quite practical (for example, the "OWA" series of designs developed by WA3FET and others at Pennsylvania State University [<http://www.naic.edu/~angel/kp4ao/ham/owa.html>] so I would not need a matching network. The feedline could be soldered directly to the driven element, much the same as in WA5VJB's designs.

I actually made two computer models, one using the old YA program from *The ARRL Antenna Book*, and the other using 4NEC2 (<http://www.qsl.net/4nec2/>).

The YA model just assumed the driven element was an ordinary dipole without the offset and overlap since YA can't model it properly. The antenna dimensions were tweaked until I got the best performance I could, and the two computer models agreed reasonably well. The gain and patterns were pretty closely matched between the two programs, but there was an offset between the frequencies at which they predicted the minimum standing wave ratio (SWR) would occur.

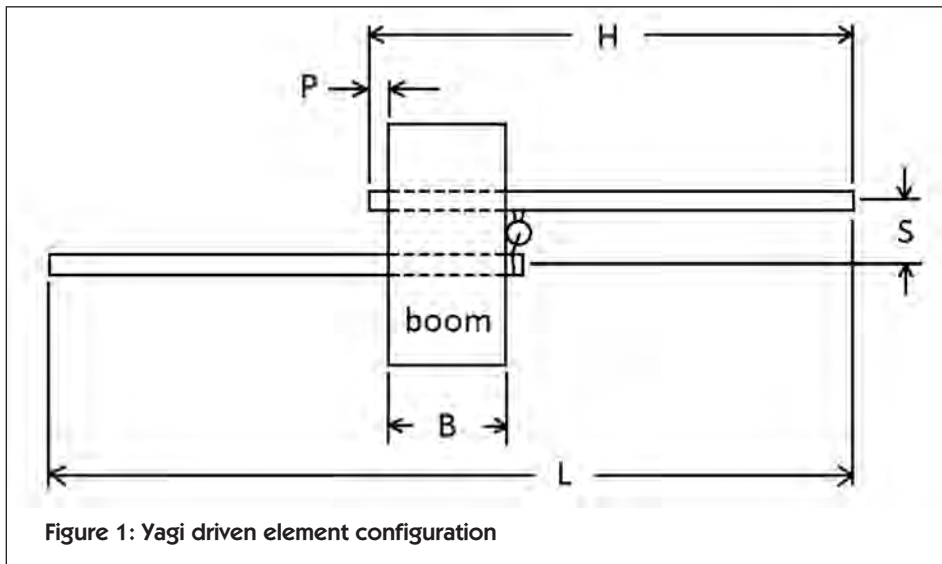

I picked a design that had acceptable SWR in both programs, figuring that would probably ensure the real antenna had decent SWR too. To this model I applied a small length correction to the parasitic elements to account for them being solid rod, and then built my first antenna, a 4-element design. This worked quite well so I went on and designed and built a 7-element Yagi, which I have been using for a few years in various portable activities.

CONSTRUCTION

Both of these antennas use 1/8-inch aluminum welding rod for the reflector and directors, and 1/8-inch hobby brass tubing for the driven element. They are pushed through holes drilled in the 1 x 2 or 1 x 3 softwood boom and epoxied in place.

The driven element epoxy is applied after soldering the feed coax to the element halves.

Both of these antennas use a short piece of coax with a female connector mounted on a small bracket.

Between the connector and the feedpoint is a slip-on ferrite choke (unknown material type from a surplus store!). This seems to work quite well as a balun – at least for the low power (about 20 watts) that I use on 222 MHz.

A little bit of woodworking effort to taper the boom toward the ends and round off the corners is well worthwhile to reduce the weight and wind area.

The booms are given a couple of coats of spar varnish to protect them from the elements, but weather resistance of the feedpoint is perhaps a bit questionable. Figure 2 shows the details of the feed for the 7-element Yagi.

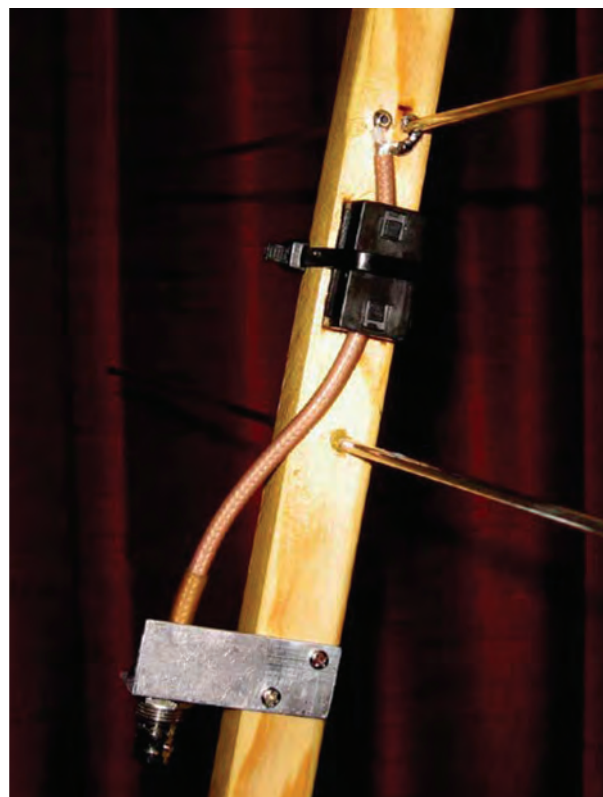

Figure 2: Feed arrangement for the 7-element antenna

AMATEUR RADIO SERVICE CENTRE

Industry Canada
 Amateur Radio Service Centre
 2 Queen Street East
 Sault Ste. Marie, ON
 P6A 1Y3
 Email: spectrum.amateur@ic.gc.ca
 Tel: 1-888-780-3333 (Toll free)
 Fax: 1-705-941-4607

PERFORMANCE

The predicted gain versus frequency for these two antennas is shown in Figure 3. The models used perfectly conducting elements and the real gain should be around 0.1 dB lower due to the resistance of the element material.

The measured SWR is shown in Figure 4 on the next page. Unfortunately, my measurement capabilities don't cover the upper end of the band. However, I think at least the 4-element antenna will be useful for FM/repeater operations at the high end as well as SSB/CW near 222 MHz

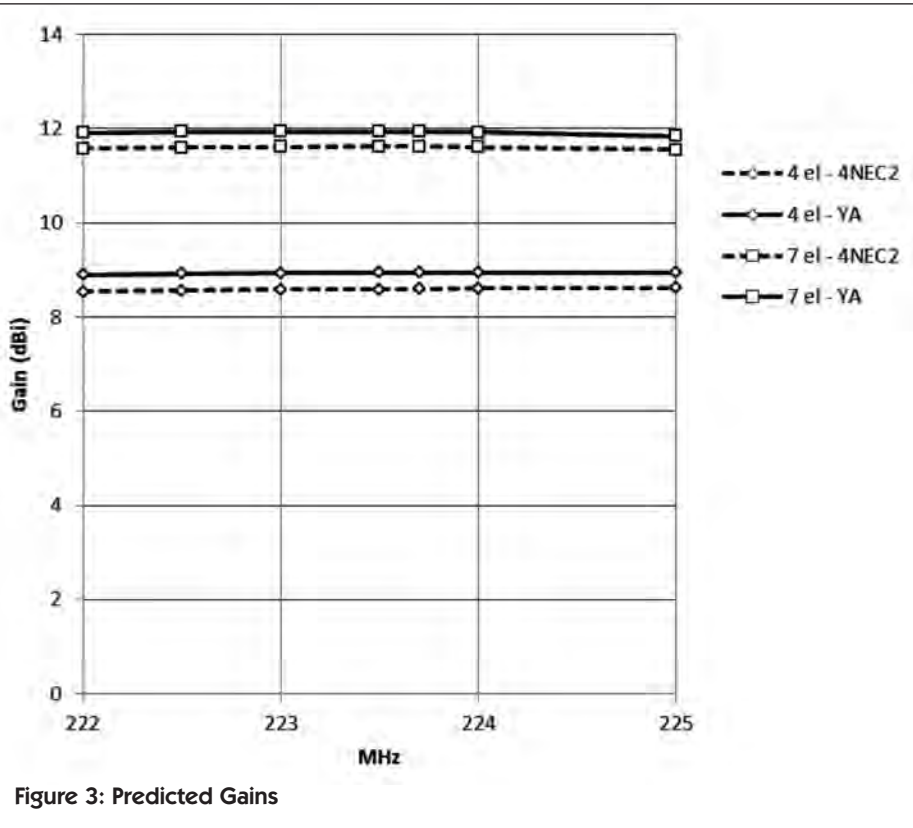

Figure 3: Predicted Gains

The dimensions for the 222 MHz antennas are given in the following tables. The dimensions for the two halves of the driven element are identical.

TABLE 1: 4-ELEMENT 222 MHZ YAGI DIMENSIONS (MILLIMETRES)

Dimension	Reflector	Driven Element	Director 1	Director 2
Overall element length L	666	648	623	600
Centre-to-centre distance from reflector	0	177	271	514
Length of driven element half		334	File: 222Y3-4.nec To access the file please visit the RAC website at: http://wp.rac.ca/tca-content-july-august-2015/	
Boom thickness B		17		
Offset between driven element halves S		8		
Protrusion of element halves through boom P		1.5		

TABLE 2: 7-ELEMENT 222 MHZ YAGI DIMENSIONS (MILLIMETRES)

Dimension	R	DE	D1	D2	D3	D4	D5
Overall element length L	680	648	620	608	596	601	589
Centre-to-centre distance from reflector	0	183	264	472	737	1125	1494
Length of driven element half		336	File: 222J805.nec To access the file please visit the RAC website at: http://wp.rac.ca/tca-content-july-august-2015/				
Boom thickness B		19					
Offset between driven element halves S		8					
Protrusion of element halves through boom P		2.5					



Figure 5: 7-element 222 MHz Yagi

and the FM simplex calling frequency at 223.5 MHz. Figure 5 shows the completed 7-element Yagi installed on a mast.

The 4-element antenna has only been used a little, but the 7-element has been in use for all of my 222 MHz operating for several years and it has worked well, with plenty of QSOs at over 500 kilometres distance using 20 watts of CW or SSB.

I haven't been able to make careful gain measurements on either of them, but a fairly rough comparison did show that the 7-element antenna has more gain than the old 6-element which, in turn, has more gain than the 4-element.

If you need to adjust the SWR a little for your application, you can cut a little bit off one or both ends of the driven element or solder on a small piece of wire to make the element longer.

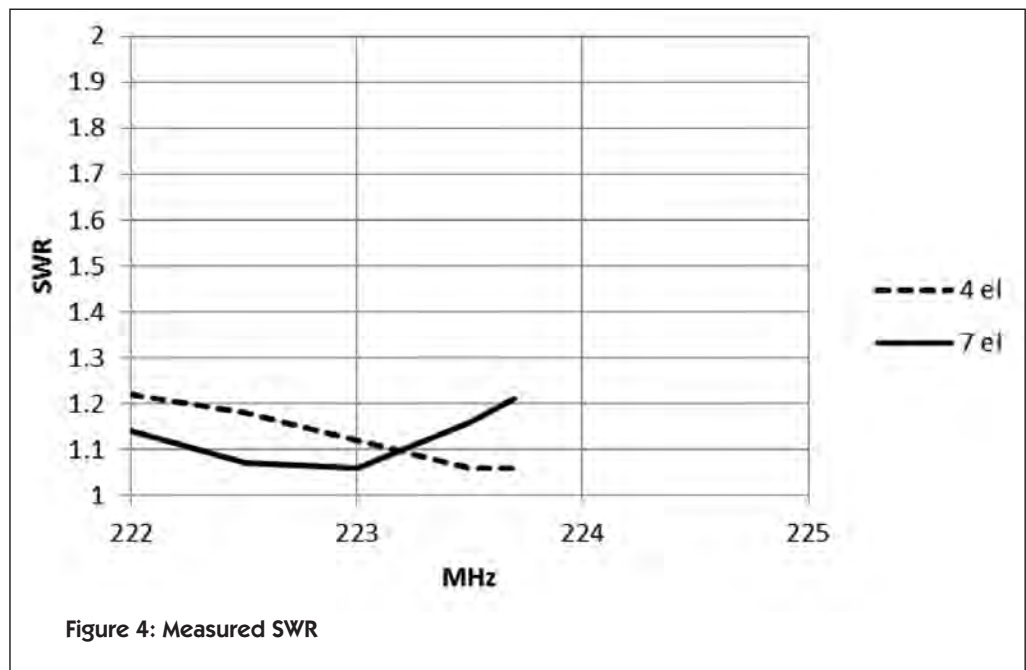

Figure 4: Measured SWR

Steve was first licensed as VE1BCZ in 1974. After receiving electrical engineering degrees from the Universities of New Brunswick and Toronto, he became a member of the technical staff at COM DEV in Cambridge, Ontario where he designed antennas for the Iridium communications satellites. In recent years he has been a consultant for exactEarth in Cambridge on global vessel tracking using satellites. His Amateur Radio interests are primarily focused on the VHF to microwave bands where he is a keen contester and antenna builder.

Note: TCA is best viewed in colour on the RAC website at <http://wp.rac.ca>



AMATEUR RADIO SATELLITES



Keith Baker, VA3KSF/KB1SF
PO Box 33
Corunna, ON N0N 1G0
E: va3ksf@rac.ca

In my last column I shared a bit of early Amateur satellite history with you. In this, and subsequent columns, I'll continue with this history lesson and also share some very exciting news about some of the latest developments in the Amateur Radio satellite world. In many ways, the Amateur Satellite Service has now gone from "famine to feast" with launch opportunities which will allow us to (quite literally) take Amateur Radio where it has *never gone before*. But first, here's more of the history lesson:

AMSAT MANAGEMENT APPROACH

Since its birth in 1969, AMSAT has grown into an international organization that has spun off a number of affiliate organizations in other countries. While the affiliations between the groups are not formal, they do often enter into one-time agreements to help each other with space-related projects.

That is, most of the subsequent work done on Amateur satellites since OSCAR 5 has been by way of international efforts where teams of volunteers from one or more countries have helped build, launch and/or control each other's satellites.

Portions of this article previously appeared as "Amateur Radio Satellites - From Famine To Feast" in the June 2015 edition of The Spectrum Monitor Magazine. Thank You TSM!.

Usually, one or more national group(s) define the basic spacecraft and its interface requirements. Then, teams are formed from the various international pools to be responsible for the various systems and subsystems of the spacecraft. This gives AMSAT's design engineers substantial flexibility to create and manufacture innovative subsystem designs.

Usually, any design is acceptable as long as it meets AMSAT's basic operational criteria. This approach also allows each group to take maximum advantage of whatever materials and resources they already have on hand (or whatever they can find in the form of leftover materials or donations of materials from the aerospace industry!).

AMSAT's major source of operating revenue is obtained by offering yearly or lifetime memberships in the various international AMSAT organizations. Membership is open to Radio Amateurs and to others interested in the Amateur exploration of space. Modest donations are also sought for tracking software and other satellite-related publications at Amateur Radio gatherings.

In addition, specific spacecraft development funds are established from time to time to receive both individual and corporate donations to help fund major AMSAT spacecraft projects. For instance, such a fund has now been established at AMSAT's North American headquarters to help support the FOX project. However, in corporate terms, these funds usually yield operating capital that's *well below* project budgets for comparable commercial satellite activities. For example, AMSAT-North America's *entire* operating budget for 2015, including *all* the development and launch campaign funding generated from member donations toward the FOX project – amounts to just over \$350,000.

From a personnel standpoint, AMSAT-North America is a *true* volunteer operation. The only person in the entire 3500-member organization



A worker at California Polytechnic Institute (CalPoly) in San Luis Obispo, California prepares the FOX-1A satellite for inclusion into the carrying structure that will take it to orbit. (Courtesy: CalPoly via AMSAT)

FOX-1 is shown in the photo below (along with its NASA "ticket to ride" just prior to insertion into its "P-Pod" carrying structure. (Courtesy: AMSAT)

drawing a paycheck is our office manager at our headquarters near Washington, DC. She conducts the day-to-day business of membership administration and other key organizational tasks.



The rest of us, from the President of the Corporation on down to the workers designing and building space hardware, all donate their time and talents to the organization.

While use of a decentralized, all-volunteer "army" does have its drawbacks in managing a space program, the dividends are enormous in that it allows a single project to draw on the talents of many highly capable and well-motivated people. Many of these volunteers are also aerospace professionals. To them, the aura of building, launching, controlling and then actually *using* the fruits of their labour once the satellite is in orbit is a powerful motivator for them to contribute their very best professional efforts. In addition, because vast sums of money are simply not available for development efforts, AMSAT's management philosophy encourages innovation

FREQUENCY AND MODE DATA				
Satellite	Mode	Uplink (MHz)	Downlink (MHz)	Beacons (MHz)
Fox-1A	U/V (Mode B)	435.180	145.980	FM Voice



Jerry Buxton, NOJY, AMSAT VP of Engineering poses at CalPoly with the fruits of his and his team's labour: the flight-ready FOX-1A satellite. Jerry is wearing the typical "bunny suit" that all spacecraft integrators wear during handling to ensure they don't inadvertently contaminate these fragile payloads with such things as lint, dust, human hair and/or oily fingerprints. These are all contaminants that can severely damage a spacecraft and shorten its lifetime in orbit when subjected to the harsh environment of space. (Courtesy: CalPoly via AMSAT).

and simplicity by not "over specifying" the spacecraft's design criteria. During development, subsystem designs are based predominantly on interface specifications with the rest of the spacecraft rather than by reams of detailed technical specifications at the subsystem level. The KISS approach – short for "Keep it Simple, Stupid" – is far more than just a buzzword for AMSAT's design engineers. KISS, quite literally, permeates the *entire* management and design philosophy of AMSAT's operations.

OSCAR SATELLITE CONSTRUCTION CHARACTERISTICS

As would be expected after over five decades of technological improvements, substantial advancements have been made in the features and capabilities of the OSCARs. However, the "homebrew" flavour of these satellites lives on even in the most current AMSAT spacecraft designs.

For example, a substantial number of the subsystems for OSCAR 13 (one of AMSAT's previously operational high altitude OSCARs) were concocted in home workshops. Several pieces of the spacecraft's structure were purchased from an electronic surplus store in the Orlando, Florida area. In addition, *all* of AO-13's fiberglass module mounting rails were cured in the kitchen stove of one of our (then) AMSAT Vice-Presidents! Material for spacecraft thermal blankets were also donated to the cause and were subsequently hand sewn together by yet another AMSAT volunteer in their basement workshop.

Elements of AMSAT's Phase 3-D spacecraft (which later became OSCAR 40 on orbit) were fabricated using similar "bargain basement" techniques. For example, the satellite's 20-foot solar array (which was also fabricated from donated parts) was designed and built to be both deployed and stabilized on orbit using a device no more complex than a simple "bar door" hinge.

The spacecraft's structure was made from ordinary sheet aluminum that was subsequently painted for thermal balance considerations. In addition, many of the spacecraft's antennas were made from ordinary flexible steel carpenter's rule material and its kick motor and batteries

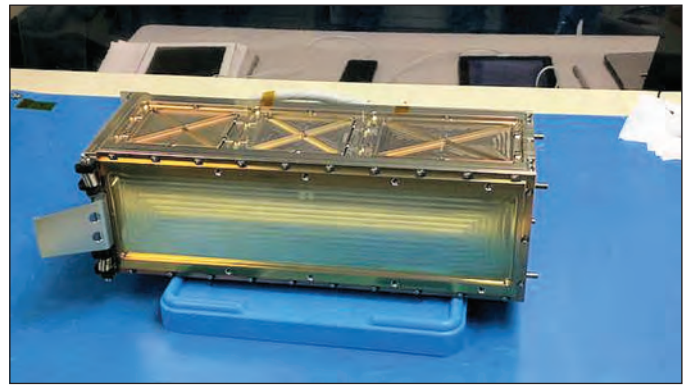

FOX-1A's P-Pod. (Courtesy: AMSAT)

consisted of leftover parts donated (or offered to AMSAT at substantially reduced cost) by aerospace corporations both here and abroad.

I'll continue with this "history lesson" in subsequent columns, but now there's some *big news* to report about AMSAT's current projects.

FOX-1A NEWS

In late April 2015, Jerry Buxton, NOJY, AMSAT-NA's Vice-President for Engineering, took the recently completed flight model of AMSAT's FOX-1A satellite to California Polytechnic Institute (CalPoly) in San Luis Obispo, California, for final integration into its launch carrier. As I've been reporting to you in previous columns, FOX-1A is now slated to be placed into orbit via Educational Launch of Nanosatellites (ElaNa) mission number XII aboard an ATLAS-5 launch from Vandenberg Air Force Base in California later this fall.

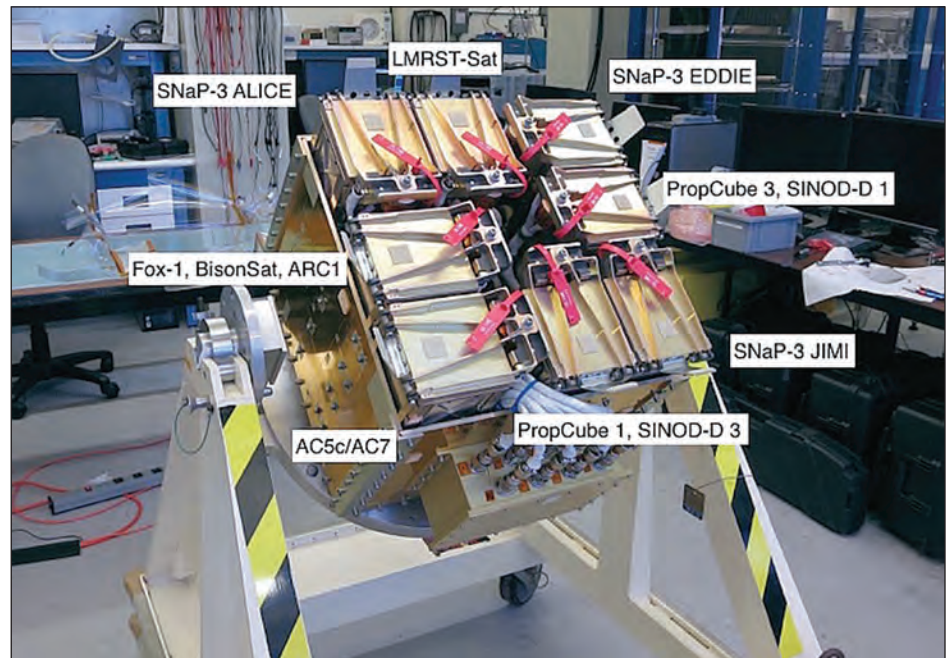

ElaNa Mission XII P-Pods mounted in the structure that will carry them all to orbit. (Courtesy: CalPoly via AMSAT)



Mission logos decorate the outside of the shipping container for the ELaNax XII mission. Note the AMSAT FOX logo. (Courtesy: CalPoly via AMSAT)

As you can see from the photos, FOX-1A will be only one of several small CubeSats that will fly on that launch, all ejected into orbit from carrying structures called "P-Pods". As I also noted in a previous column, in many ways this launching mechanism closely resembles one of those spring-loaded, cloth "snakes in a can" that we all used to buy at joke shops that quickly sprang out when an unsuspecting victim opened the lid. In this case, however, the lid is opened remotely when it's time for the satellites to be launched into their own orbits.

Jerry reports that "all went well" with the integration as he said goodbye to his and his team's handiwork. At press time (mid-May) The launcher containing the satellites had already been handed over to the US Military for eventual mounting on the ATLAS-5's upper stage.

FOX-1C DEVELOPMENTS

In other FOX news, Jerry Buxton, N0JY, also announced plans to incorporate an L-Band receiver in FOX-1C and FOX-1D.

This addition will allow ground commanded selection of the U/V (normal FOX-1 bands) or the new L/V 1.2 GHz (23 cm) mode. Both bands will operate as an FM single channel.

Rather than adding a complete new receiver, the L-Band "Project Downshifter" will convert the received L-Band signal down to the FOX-1 uplink frequency and feed it to the regular UHF receiver on the FOX-1 satellite.

The design will not require an additional

antenna on the satellite because the existing UHF antenna will also work for L-Band receive as well. The FOX team is also planning to design an affordable L band uplink ground station that will be available to Amateurs by the time FOX-1C is on orbit.

FOX-1D AND FOX-1E

In further news, Jerry announced the plan to construct a FOX-1E "Evolution" variation of the FOX-1 series which will carry a Mode J linear transponder. The transponder is planned to be 30 kHz-wide and will also include a 1200 bps BPSK telemetry beacon.

The purpose of the project is to test a design for a linear transponder that could be made available to CubeSat builders as a secondary (or even primary) radio payload thus bringing more opportunities for Amateur Radio in space as well as offering AMSAT's proven communications skills as a telemetry option.

Lastly, now that FOX-1A is on its way to launch, AMSAT has recently been approached for a launch opportunity for FOX-1E sometime in 2016, but specific launch details are not known at this time.

AND NOW... FOR THE REALLY BIG AMSAT NEWS!

AMSAT is also excited to announce that they have now accepted an opportunity to participate in a potential rideshare as a hosted payload on a geosynchronous satellite (GSO) planned for launch in 2017. An Amateur Radio payload, operating in the Amateur Satellite Service, will fly on a spacecraft which Millennium Space Systems (MSS) of El Segundo, California is contracted to design, launch and operate for the US government based on their Aquila M8 Series Satellite Structure.

A geosynchronous orbit (sometimes abbreviated GSO) is an orbit around the Earth with an orbital period of one sidereal day, and which intentionally matches the Earth's rotation period (approximately 23 hours 56 minutes and 4 seconds). Satellites in these orbits appear to "hang" in roughly the same place in the sky, thereby allowing fixed antennas to be used on the ground. For example, this is the orbit where most large TV satellites are currently "parked".

The AMSAT transponder is expected to support a wide range of voice, digital and experimental advanced communications technologies. A decision is expected "soon" specifying the microwave uplink and downlink bands. Additional information on the Aquila M8 Series Satellite can be viewed online at: <http://www.millennium-space.com/> and at <http://www.millennium-space.com/platforms#aquila>.

WRAP UP

Needless to say, it's an exciting time for Amateur Radio in space. Stay tuned to the AMSAT website (<http://www.amsat.org>) for all the very latest Amateur satellite news. In future columns, I'll continue with our "history lesson" as well as bring you up-to-date on these and other satellite projects. See you then.

SELECTED REFERENCES

Keith Baker and Richard Jansson, "Space Satellites from the World's Garage: The Story of AMSAT", Dayton, Ohio: Proceedings of the National Aerospace and Electronics Conference, 1994.

Martin Davidoff, *The Satellite Experimenter's Handbook*, Newington, Connecticut: The American Radio Relay League, 1984.

Richard Jansson, "Spacecraft Technology Trends in the Amateur Satellite Service", Ogden, Utah: Proceedings of the First Annual USU Conference on Small Satellites, 1987.

WRC-15 Update: Conference Preparatory Meeting

The next World Radiocommunication Conference (WRC-15) is scheduled to take place from November 2 to 27 at the International Telecommunications Union in Geneva, Switzerland. In preparation for the Conference, Study Groups have been meeting regularly in Geneva and elsewhere since the WRC-15 agenda was set in 2012.

Radio Amateurs have a profound interest in these meetings since our frequencies – and who can use them and how – are explicitly provided for in the international treaty which WRC-15 will update later this year.

The delegates who will vote on the Agenda Items at the Conference will have before them a set of detailed briefing notes called Conference Preparatory Material (CPM), which summarize the recommendations for and against various proposed changes to the Radio Regulations. These documents were finalized by over 1,500 delegates at the second Conference Preparatory Meeting (CPM2) which was held in late March at the Geneva International Conference Centre. In this article I am going to try to set out which of the Agenda Items may have an impact on Amateur Radio operations and I invite you to keep score as to how these play out at the WRC later this year.

Agenda Item 1.4 proposes a secondary allocation to the Amateur Service somewhere in 5250 to 5450 kHz. Going in to the Conference it is proposed that this be implemented by “one or more segments of spectrum not necessarily contiguous” in 5275 to 5450 kHz (or in 5350 to 5450 kHz). An option from China suggests a total of 15 kHz, but China and other administrations have not ruled out more spectrum. There is also a proposal for an undefined number of “spot” frequencies similar to what Canada and the US have now. Finally, the Russian Federation and others propose no allocation to Amateur Radio.

Canada has indicated a preference for two 25 kHz segments at 5330 and 5405 kHz; however, our partners in the CITEL (Inter-American) regional grouping have thus far favoured the more general proposal.

Agenda Item 1.6.1 proposes an additional 250 MHz as a primary allocation in Region 1 for the fixed-satellite service (earth-to-space and space-to-earth)



The CPM2 Meeting in session at the Geneva International Conference Centre. Part of the Canadian delegation can be seen in the foreground.

Agenda Item 1.18 proposes a primary allocation to the radiolocation service for use by vehicle collision-avoidance radar systems in 77.5 to 78 GHz. The Amateur Radio Service has a primary

somewhere in 10 to 17 GHz. The Amateur Radio Service has a secondary allocation here in 10 to 10.5 GHz. The studies which support this Agenda Item suggest that co-existence with existing users in 10 to 10.5 GHz may be difficult, and all the CPM proposals for an allocation are in the vicinity of 14 GHz. Again, this proposal is for an allocation in ITU Region 1 only.

Agenda Item 1.10 proposes additional spectrum to the mobile satellite service (earth-to-space and space-to-earth) in 22 to 26 GHz. Radio Amateurs have an allocation in 24 to 24.25 GHz of which 24.0 to 24.05 GHz is primary. None of the proposed methods of implementing this Agenda Item overlap our Amateur allocations and, barring unforeseen and unlikely changes during the Conference, there seems little threat to our 1.25 cm Amateur band.

Agenda Item 1.12 proposes an additional 600 MHz allocation for the Earth Exploration Satellite Service (EESS). All of the proposed methods for implementing this Agenda Item (excluding the “no change” method) recommend an allocation using some or all of the range 9.9 to 10.5 GHz. If allocated, this would overlap all or portions of the 10 to 10.5 GHz range where Amateurs have a secondary allocation. Text has been added to the CPM document highlighting the requirement that use of the extended allocation, if granted, should not jeopardize the Amateur Radio Service. Nonetheless, it is thought that the use and duty-cycle of these satellites, were they to share spectrum with us, should pose minimum risk to our Amateur microwave activities.

allocation here; however, our analysis of the proposed automotive radar application is that it should not cause undue distress to typical Amateur Radio operations in 77.5 to 78 GHz. Those operations are typically from mountain tops or a high building and are not expected to be impacted by emissions from vehicles on the surface. In general, the range of possible interference is estimated at 200 metres at the surface. There is an alternate proposal for 1.18 which would define vehicles to include non-surface vehicles, e.g., helicopters. Amateurs have made the case that our acceptance of this proposed allocation would be for an allocation involving surface vehicles only.

A final outcome of WRC-15 will be to finalize an agenda for the next WRC which is widely expected to be organized for 2018 or 2019.

There are a rather small number of national societies who have the opportunity and resources to be involved in the preparations for and deliberations during these Conferences. Canada is fortunate to be among them; first, by virtue of a cordial and fruitful working relationship with our regulator – Industry Canada – and, second, through the generosity of Canadian Amateurs in their support of the Defence of Amateur Radio Fund (DARF; see page 59).

There is much more to follow later this year from the WRC-15 Conference so stay tuned to TCA for further updates.

*Bryan Rawlings, VE3QN
Special Advisor WRC-15
Radio Amateurs of Canada*

CALL FOR NOMINATIONS / MISE EN NOMINATION

THE CANADIAN AMATEUR RADIO HALL OF FAME

TEMPLE DE LA RENOMMÉE DES RADIOAMATEURS CANADIENS

Any resident of Canada who holds a current Amateur Radio Operator Certificate issued by the Government of Canada, or any Canadian Amateur Radio organization, other than Radio Amateurs of Canada, may submit a nomination for Member of the Canadian Amateur Radio Hall of Fame. Membership in RAC is not mandatory.

Any resident of Canada who holds a current Amateur Radio Operator Certificate issued by the Government of Canada, except a Radio Amateurs of Canada employee, officer, Director, Assistant Director, volunteer manager, or leadership official in the Field Organization, may be appointed as a Member of the Hall. Membership in RAC is not mandatory. Any eligible person may receive an appointment as Member of the Hall for outstanding achievement and excellence of the highest degree, for serious and sustained service to Amateur Radio in Canada, or to Amateur Radio at large.

Nomination or appointment for Member or Honorary Member of the Hall may be after the death of the nominee.

A person who is not a resident of Canada may be appointed only as an Honorary Member of the Hall. The other requirements for appointment as Honorary Member of the Hall are the same as for Member.

Only the RAC Board of Directors, by majority vote, is allowed to nominate candidates for Honorary Member (those persons not residents of Canada). Because of the requirement for Canadian residency for appointment as Member of the Hall, it is incumbent upon the nominator to confirm the Canadian residency of a nominee prior to submitting a nomination.

Nominations shall be submitted to the Board of Trustees using the Canadian Amateur Radio Hall of Fame Nomination Form which is available on request from RAC Headquarters or for download from the RAC website at <http://wp.rac.ca/wp-content/plugins/s2member-files/files/HoF/nomination-form.pdf>. All nominations shall include a biographical sketch or curriculum vitae. Three references shall be included for Member of the Hall.

All nominations for Member of the Canadian Amateur Radio Hall of Fame must be received at RAC Headquarters by the close of the last business day of September.

Late nominations will be considered in the next year. Once received, all handling shall be conducted in a secure and confidential manner. On or before the last business day of November, the Chair of the Board of Trustees for the Hall of Fame shall advise the Custodian (RAC) of the decisions of the Board of Trustees on appointments for the calendar year.

The Board may appoint a person who has been nominated in a previous year. For this reason, no advice shall be issued to the nominator that the nomination has not resulted in an appointment, nor any reason given why an appointment has not been made as a result of that nomination.

Tout résident du Canada qui détient un certificat régulier de radioamateur émis par le gouvernement du Canada, ou toute organisation radioamateur canadienne autre que Radio Amateurs of/du Canada, peut proposer une candidature au titre de membre du Temple de la Renommée des Radioamateurs Canadiens. Être membre de RAC n'est pas obligatoire.

Tout résident du Canada qui détient un certificat régulier de radioamateur émis par le gouvernement du Canada, sauf un employé de Radio Amateurs of/du Canada, dirigeant, directeur, assistant directeur, gestionnaire bénévole ou chef attiré dans l'Organisation sur le terrain, peut être choisi comme membre du Temple de la renommée. Être membre de RAC n'est pas obligatoire. Toute personne éligible peut être admise au Temple de la renommée pour réalisations hors du commun et de haut niveau relativement à son engagement sincère et soutenu envers le radioamateurisme canadien, ou le radioamateurisme en général.

La mise en nomination ou le choix d'un membre régulier ou honoraire au Temple de la renommée est possible à titre posthume.

Une personne qui ne réside pas au Canada peut devenir membre du Temple de la renommée à titre honoraire seulement. Les autres prérequis de mise en nomination honoraire sont similaires à ceux réservés au membre.

Seulement le Bureau des directeurs, majoritairement, est habilité à nommer un candidat honoraire ne résidant pas au Canada. En raison de l'obligation de résidence canadienne pour une nomination au titre de membre du Temple de la renommée, il est impératif pour celui qui nomme un candidat de s'assurer de sa résidence canadienne avant de présenter sa candidature.

Les mises en nomination devront être présentées au Conseil d'administration du concours (Board of Trustees) au moyen du formulaire "Canadian Amateur Radio Hall of Fame" disponible sur demande au siège social de RAC. Le formulaire peut être téléchargé à partir du site web de RAC à <http://wp.rac.ca/wp-content/plugins/s2member-files/files/HoF/nomination-form.pdf>. Toute nomination doit inclure un résumé biographique ou un curriculum vitae (CV) du candidat. Trois références doivent accompagner le formulaire de mise en candidature.

Toute mise en nomination au Temple de la Renommée des Radioamateurs Canadiens doit arriver au siège social de RAC avant la fin du dernier jour ouvrable de septembre.

Les mises en nomination retardataires seront prises en compte l'année suivante. Une fois reçue, la mise en nomination sera traitée de façon sécuritaire et confidentielle. Le ou avant le dernier jour ouvrable de novembre, le président du Conseil d'administration du Temple de la renommée avise le responsable (RAC) de la décision du Conseil relativement aux mises en nomination de l'année.

Le Conseil peut nommer une personne nommée l'année précédente. Pour cette raison, aucun avis ne sera fourni au proposeur lui indiquant que la mise en nomination est demeurée sans résultat, ni tout autre raison indiquant le non choix du candidat.

Radioworld

Canada's favourite Amateur Radio Stores!

SIGN UP AND WIN!



Each month we will draw a name from our Amateur Radio Newsletter Contact List and a lucky customer will WIN a \$100 Radioworld Gift Certificate

sign up at

www.radioworld.ca/TCA

Radioworld central
Toronto, ON
866-666-8600

Radioworld
Calgary, AB
800-585-9331

CALL FOR NOMINATIONS: RAC AMATEUR OF THE YEAR AWARD

To qualify for the title "Amateur of the Year", an individual should have made an outstanding contribution to Amateur Radio in the past year, or have contributed consistently to the welfare of Amateur Radio over several years. RAC Directors, Officers and Section Managers are not eligible for the award while in office, and not in respect to their term(s) of office.

Nominations with supporting documentation are to be addressed to the Secretary, RAC, and received at RAC Headquarters by the close of the last business day of September, for consideration for the current year.

Selection of the winning candidate will be by majority vote of the RAC Board of Directors based on the supporting documentation submitted with the nomination. The winning candidate will be notified by mail.

Due recognition will appear in *The Canadian Amateur* and a suitable plaque will be presented at an appropriate time and place.



For the RAC Store visit:
http://www.cafepress.ca/rac_radio

MISE EN NOMINATION : RIX AMATEUR DE L'ANNÉE DE RAC

Pour se qualifier au titre « Amateur de l'année », une personne doit avoir fourni une contribution hors du commun à la cause radioamateur au cours de l'année qui se termine, ou avoir travaillé substantiellement au bien-être du radioamateurisme depuis plusieurs années. Les directeurs de RAC, dirigeants et gérants de section ne sont pas éligibles au Prix aussi longtemps qu'ils sont en fonction, et sans considération quant à leur(s) mandat(s).

Les mises en nomination, documentées, doivent être envoyées au secrétaire de RAC de manière à ce qu'elles parviennent au siège social de RAC au plus tard à la fin du dernier jour ouvrable du mois de septembre pour être prises en considération la même année.

Le choix du candidat gagnant est effectué à la majorité des membres du Bureau des directeurs, basé sur la documentation accompagnant la mise en nomination. Le candidat gagnant est avisé par la poste.

The Canadian Amateur (TCA) publiera un texte de félicitation et une plaque sera remise au récipiendaire en temps et lieu appropriés.

HELP WANTED

TREASURER

The Radio Amateurs of Canada is looking for a Treasurer who is a Chartered Accountant, Certified General Accountant or Certified Management Accountant. A certification in Amateur Radio is optional.

As RAC's financial advisor, we need someone to provide direction on the accounts and act as liaison with the external auditors. Experience with QuickBooks would be an asset.

Radio Amateurs of Canada is a non-profit corporation providing services to members and has a mandate to enhance Amateur Radio in Canada.

Please speak with your friends; there must be a RAC member who either qualifies or can approach someone for this volunteer position. Certification in Amateur Radio is not a requirement for this position.

Interested parties please contact RAC Headquarters at 720 Belfast Road, Suite 217 Ottawa ON, K1G 0Z5 or by email at racgm@rac.ca.

RAC CORPORATE SECRETARY

We are actively seeking the services of a volunteer to fill the position of RAC Corporate Secretary. This is a challenging responsibility that requires attention to detail and the ability to capture accurate notes and records of meetings, among other responsibilities.

A detailed position description may be viewed in the RAC Administration Manual, Section 2.19. The Secretary reports to the RAC President; this position is available immediately.

Interested parties please contact RAC Headquarters at 720 Belfast Road, Suite 217 Ottawa ON, K1G 0Z5 or by email at racgm@rac.ca.

Yaesu Fusion Technology

A look inside the latest technology from Yaesu and a look at the Yaesu FTM-400DR/DE dual band digital/analog mobile

Mike Richards, G4WNC

AMATEUR DIGITAL VOICE

The Yaesu Fusion digital radio system brings another digital mode into the Amateur marketplace. Yaesu's late entry to the market was a deliberate strategy as they wanted to gauge the requirements before committing their design. As a result, the Yaesu Fusion systems focuses on providing high quality digital voice to the world of Amateur Radio. Yaesu have also adopted a novel approach to repeaters with their dual function repeater system – but more on this later.

Let's start with a look at the Yaesu Fusion digital system. The digitization starts with the microphone signal, which begins its life as an analog signal. The conversion of analog speech signals into a digital format has been the focus of much research work in recent times. Commercially, there is great interest in squeezing speech signals into as narrow a bandwidth as possible. This not only applies to radio systems, as telecoms operators have the same problem and need to ensure maximum utilization of their expensive, high bandwidth channels. For Radio Amateurs this is good news because we can benefit from heavily funded mainstream research projects.

Although a voice signal can be digitized by passing it through an analog-to-digital converter (ADC), this would require a bandwidth of around 64 kilobits per second (kbs) for a 0 to 4 kHz communications speech channel. While this approach is very simple, 64 kbs is way too much data so a better system was required. Thus were developed ways of encoding the digital voice data in a device known as a vocoder (VOice enCODER).

One of the most successful and widespread vocoder systems is the AMBE (Active Multi-Band Excitation) produced by Digital Voice Systems Inc (DVSI). Originally developed at the Massachusetts Institute of Technology (MIT) in the US, AMBE vocoders have been clear winners in a number of commercial vocoder comparison studies.

This article was first published in the January 2015 issue of RadCom and is being reprinted with the permission of its publisher, the Radio Society of Great Britain. Thank you Elaine!



The Yaesu FTM-400 has a touchscreen remote control head.

The AMBE vocoders operate by sampling the voice signal and splitting it into a number of bands as shown in Figure 1. Each band is analyzed for voice content and those bands without voice are attenuated or discarded, while the others pass through for further processing.

In addition to providing better results than the competing, predictive, vocoders, the AMBE system puts a lighter load on the microprocessor, resulting in less power consumption and longer battery life, which is always welcome in portable devices.

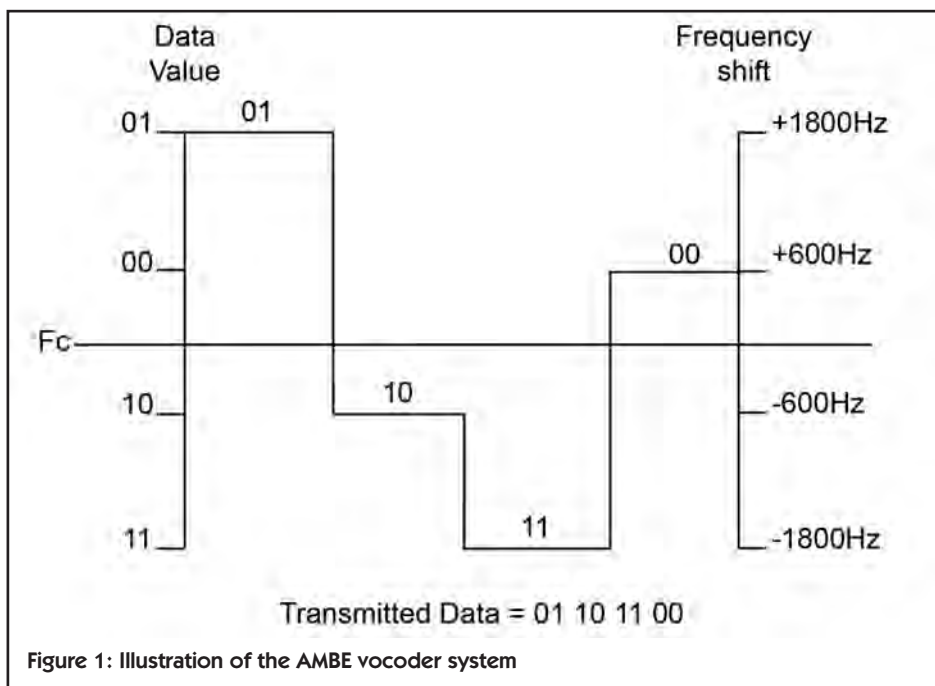

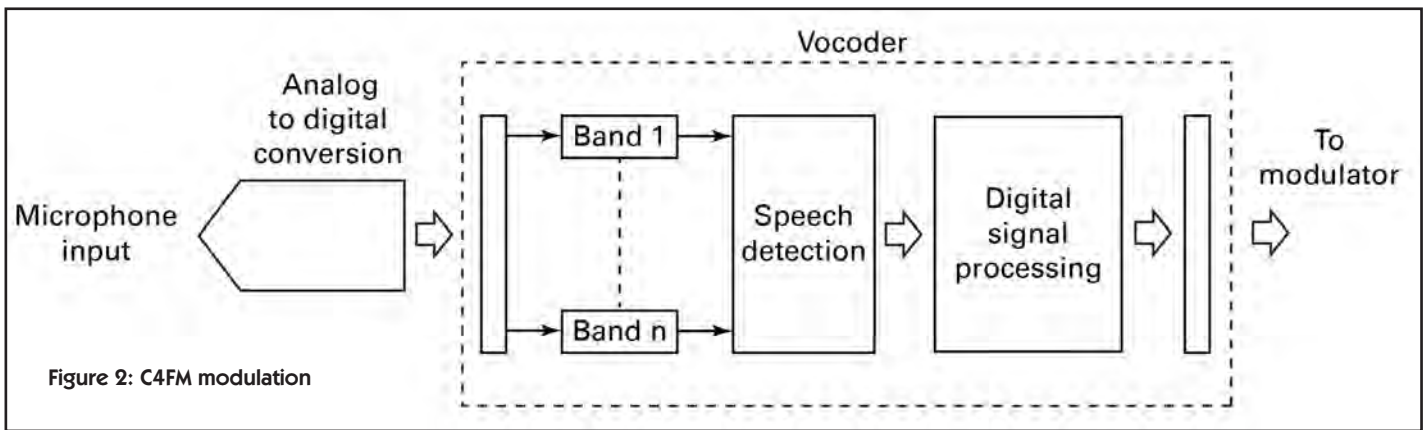

The end result of an AMBE-based system is a very compact digital communications voice channel that can run in as little as 2.4 kbs of bandwidth.

Although Yaesu haven't confirmed the use of an AMBE vocoder, it is the most likely choice and is used by the competing Amateur digital voice systems. In order to offer the Radio Amateur improved voice quality, the Yaesu Fusion system operates with a 9.6 kbs data link and includes the option to use the entire 9.6 kbs for speech.

In addition to compressing the speech signal, the vocoder is also a good place to introduce some noise reduction.

This is important because many mobile voice transmissions originate from noisy environments, e.g., vehicles, factories, building sites and so on.

DIGITAL OPTIONS

Once you have a digital radio path established, it can be used to convey anything that can be digitized and this flexibility is used to good effect in the Yaesu Fusion system. In addition to digital voice, the FTM-400 can be set to simultaneous voice and data or data only modes.

In the voice and data mode, 4.8 kbs is used for the speech signal while the other 4.8 kbs is used to convey error correction data for the voice signal plus other user data such as text messages, etc. The data mode switches the entire 9.6 kbs for data use and is useful for data intensive activities. This latter mode is put to very good use when using the optional MH-85A11U microphone with camera. This allows you to take a snapshot, display it on the FTM-400 colour screen and then transmit it over the digital link. The FTM-400 automatically handles the switch from voice to data and back again once the picture has been sent.

MODULATION SYSTEM

The Yaesu Fusion system has taken a lead from commercial private mobile radio (PMR) trends and adopted the C4FM modulation system, a Frequency Shift Keying (FSK) mode that employs four shift frequencies.

The use of four shift frequencies enables each shift to convey more than a single bit, as illustrated in Figure 2.

C4FM is also a phase continuous modulation system so the PA doesn't have to operate in linear mode. When compared with GMSK, C4FM provides better error rate for a given bandwidth and enables use of a simpler modulator circuit.

REPEATERS

With all the Amateur Radio digital voice systems it is the repeater linking that provides the main attraction. With this linking you have the potential to work the world from a simple handheld. Yaesu have realized that the changeover to digital radio is a significant problem for repeater groups and can mean having to invest in a new overlay network to support digital operation.

With three incompatible systems on the market this can be a real headache. However, with the new DR1 repeater Yaesu have produced a dual band repeater that can handle traditional analog signals as well as the new Yaesu Fusion digital signals. Not only that but it can be made to translate all incoming Yaesu Fusion digital signals into analog format on the output. This gives repeater groups the option to install digital capable repeaters while still supporting analog-based users. As the number of digital operators increases, the repeater can be set back to its standard dual mode configuration, which allows digital signals to pass through so Yaesu Fusion users can see the full benefits of the system.

There is also the facility to add a CTCSS tone while in dual-mode so that analog users don't have to listen to the harsh digital modulation. This flexible approach will no doubt appeal to many repeater groups – especially as there are some excellent discounts available. The temptation is to upgrade your local repeater with a brand new 145/432 MHz 50-watt Yaesu Fusion box at a discount price and set it to digital/analog conversion.



If digital doesn't take off then you still have an excellent analog repeater. This has the potential to ease the progression to digital voice.

In addition to being a very capable dual-mode repeater box, the DR1 can be enhanced with the WIRES-X

The Yaesu FTM-400 main unit has sockets for the control head and microphone, plus intriguing connectors for data and a microSD (Secure Digital) memory card.



Around the back of the main unit are the SO-239 antenna socket, a fan for the PA heatsink, DC in cables, an external speaker socket and a data connector.



The built-in GPS means that the Yaesu FTM-400 always knows where it is – handy for APRS.

for Fusion (HRI-200) that provides Internet linking. When activated, WIRES-X enables you to dial up a distant repeater or group of stations (Room) and make calls over great distances from a mobile or handheld rig.

DIGITAL RADIO COMPATIBILITY

I know that many are confused by the assortment of Amateur digital systems so here's some clarification. At the time of writing there are three Amateur digital radio systems available: D-Star, DMR and Yaesu Fusion. Although there are many similarities between these three systems, they are wholly incompatible. As a result, potential users have to choose a system and that choice is likely to be based on what the digital repeater support is in your area. I think Yaesu hopes its dual-mode repeater box will swing a lot of decisions its way.

YAESU FTM-400: A REVIEW

Graham Coomber, G0NBI, the General Manager of the Radio Society of Great Britain (RSGB), used the Yaesu FTM-400DR/DE for a few days and provided the following report on his findings.

OVERVIEW

The Yaesu FTM-400DR/DE dual band mobile transceiver operates on two metres and 70 centimetres and has wideband receive from 108 to 999 MHz. The transceiver automatically selects one of four modes for optimum reception, i.e., V/D mode is Voice and Data communication in the same time frame. Stable and reliable digital voice and data communications are maintained using strong error correction capabilities. This mode will be the basic mode of C4FM FDMA digital Amateur Radio.

Voice FR mode uses the full rate of data capacity for voice data. This mode enables you to transfer clear, high quality voice data.

Data FR mode uses the full rate of data capacity for transferring data. This mode enables you to transfer large amounts of data, text messages, images and voice memo data with double speed in V/D mode.

Analog FM mode is effective when weak signal strength causes audio dropout in the digital mode and enables communication up to the borderline of the noise level.

WHAT'S IN THE BOX

The unit comes with mounting hardware including brackets and screws for both the control head and the actual transceiver itself. There is no provision for mounting the control head to the transceiver – it must be mounted separately.

A generous 12.5-foot interconnecting cable is supplied.

The transceiver itself is fairly standard size: 5.5"(W) x 1.6"(H) x 4.9"(D) (w/o fan)

The control head is dominated by an easy-to-read, full-colour 3.5-inch TFT touch screen, which is used both as a display as well as for accessing the functions of the radio.

The active transmit frequency is indicated by the brightness of the display.

If you are new to touch screen radios, be prepared for a slower response time than you will be used to with a tablet or mobile telephone.

STARTING OUT

Getting the 400 up and running requires a careful study of the manual, but once you are familiar with the unit and have programmed the memories, operation is intuitive.

Five hundred memories per band are available.

Each memory can store frequency, mode, tag, repeater information, tone, DCS, antenna squelch information, memory skip information and transmission output. The touch screen comes in very handy here, allowing one to enter the data directly.

One of the receivers can be used as a small and simple spectrum allowing the user to see at a glance activity on nearby frequencies.

The receiver seems very sensitive and the audio quality is excellent.

By connecting a USB camera (not supplied) the FTM-400DR/DE can capture images or video and transmit and receive them. There is also a port for a microSD card.

On transmit, signal reports indicate that the audio on transmit is crisp and clear. Power output is selectable at 50, 20 or 5 watts on either band.

The APRS and GPS functions worked well although the manuals are not supplied with the radio.

SUMMARY

This is an impressive dual band / dual receive mobile rig which is very sensitive on receive and handles easily with a good, if slow to respond, very readable touch screen. The APRS with GPS receiver is a nice-to-have addition.

QUA – A TOPICAL DIGEST



Allen Wootton, VE7BQO
4503 Cedar Crescent
Terrace, BC V8G 1X5
E: ve7bqo@rac.ca

Like me, I'm sure that most of you found many interesting ideas and worthwhile suggestions in the March-April 2015 special QRP issue of TCA. Since I really enjoy QRP operation I found the issue especially pertinent to my operation.

In particular, I found David Conn, VE3KL's observations about QRP antennas were "resonant" with my own experiences operating in parks, on camping trips, hiking trips in summer and winter, and, finally, operating at home with a fixed antenna.

As he points out, there are occasions where you want as versatile and effective an antenna as possible, and other occasions where some compromises in performance are acceptable in exchange for light weight and easy erection.

For a number of years I have been using a 25.8 metre (84 feet) long wire antenna with two counterpoise wires of about five and 10 metres in length. To match this to my Yaesu FT-817 I use an Elecraft T1 tuner. Generally this combination has worked very well for me, except that I find it can be difficult to set up.

I find it really difficult to throw a line over a tree (or some similar support) in order to pull up the long wire. For this reason I bought a 12 metre "Spiderpole" and I have

found this to greatly simplify antenna raising.

The Spiderpole is fine for car camping or travel by canoe or kayak – where its weight and contracted length are not major problems – but it is too heavy and even when contracted it is too long for easy backpacking. Therefore, in a continuing search for the ultimate antenna offering high performance, easy setup, light weight and versatility, I started further antenna experimentation.

One of the things I liked about the long wire antenna was that the end of the antenna was also the feedpoint, a feature that simplifies erection quite considerably. For this reason other types of antennas that use a feedline connected to one end seemed like they might be worth considering. After a search through books and on the Internet I found Steve Yates, AA5TB's website in which he provided a description and methods of construction for an end-fed vertical dipole. The data he provided and the method for the construction of this antenna looked good to me so I followed his method and made one of these antennas for the 20 metre band.

This antenna is made from Teflon coated #26 stranded wire and its dimensions are shown in Figure 1.

The small box shown at the junction of the RG-174 feedline with the antenna contains a transformer to match the very high impedance of the end of the dipole to 50 ohms.

I wound this transformer on a T68-2 iron powder toroid core using a 29-turn secondary and a three-turn primary as AA5TB specified.

In addition, using my MFJ antenna analyzer in the method Steve outlined, I adjusted a variable capacitor

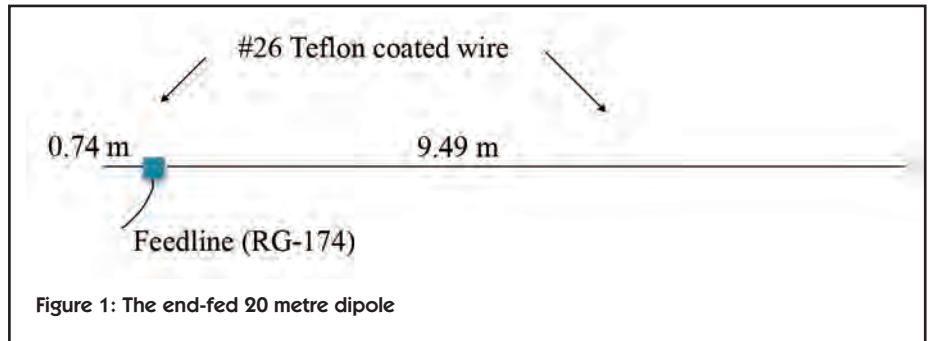

connected in parallel to the secondary to provide the lowest SWR I could achieve at about 14.05 MHz. I then measured the capacitance of the variable capacitor (25 pF) and replaced it with an equal fixed value made up of a series/parallel combination of capacitors from my junkbox. Figure 2 shows the completed transformer and the capacitors fastened into a small ABS plastic box with hot melt glue.

For a number of years I have had good success with this antenna. I find it easy to set up and it seems to work well. By its construction, my end-fed dipole is limited to power levels of about 10 watts, but commercial versions are available for at least 100 watts.

At the VE7NWZ Provincial Regional Emergency Centre station here in Terrace, British Columbia we use one of these for our 80 metre antenna where it has greatly simplified the antenna installation. Nevertheless, I was also intrigued by another type of dipole that, on casual inspection, looks similar to this end-fed dipole.



This second dipole has various names, but I will call it a "resonant feedline dipole" after the name given to it by James Taylor, W2OZH, in the August 1991 issue of QST.

You can also find more information regarding this antenna on the website of Monty Northrup, N5ESE, where he describes his experiments with the antenna at: <http://www.n5ese.com/rfd.htm>

Monty's conclusions about this antenna are not too encouraging: "While experimenting with antennas is always fun (and this was no exception), I cannot recommend these antenna designs for

Figure 2: The end-fed antenna matching transformer and associated capacitors

portable QRP use". In spite of this I thought the general idea behind the antenna was too good to pass up without some trials of my own.

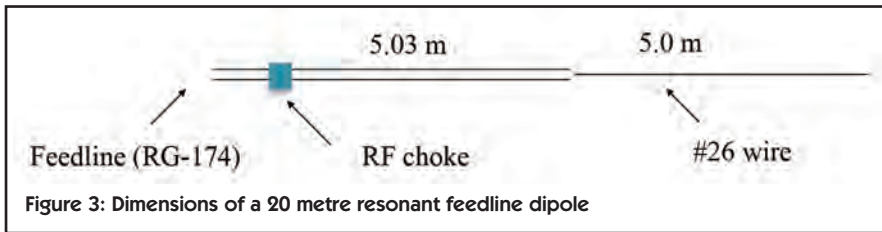

Figure 3: Dimensions of a 20 metre resonant feedline dipole

Based on my results I concluded that the two antennas are similar in performance, with a slight edge to the resonant feedline dipole.

I also felt that, while my approach to the data analysis could be refined,

The antenna is a centre-fed dipole in which the outer shield of a coax feedline is used for half the antenna and an extension of the centre conductor as the other half. In a coax feedline, current in the centre conductor should be balanced by an equal current of opposite phase flowing on the inside surface of the shield. This should be the case for the coax in this antenna up to the centre.

At the centre of the antenna, however, the shield ends while the centre conductor is extended onwards for one-quarter wavelength. At this centre point, current on the inner shield has to go somewhere (or come from somewhere) and that somewhere is the outer surface of the coax shield. It is completely separate from the inner surface of the shield because of the RF "skin effect". To limit the effective length of the coax shield section of the antenna some kind of RF choke is needed one-quarter wavelength from the centre. A diagram showing the dimensions of my 20 metre version of this antenna is shown in Figure 3.

The construction I used is different than that shown by W2OZH or N5ESE. Instead of making the RF choke from a coil of coax, I wound nine turns of RG-174 (as many as would fit) tightly around a Palomar Engineers clip on ferrite split bead mix 31 core with a half-inch centre hole (Palomar FSB-1/2). This choke is shown in Figure 4. It seems to work very effectively; touching the coax below the choke makes no measurable difference to the SWR indicated by my MFJ-259B antenna analyzer. As was the case with the end-fed dipole, I found this antenna seemed to work well for me.

Recently, I decided to collect some data so as to make a more rigorous comparison between the two dipoles.

Consequently, for several days I set up my Yaesu FT-817 for Weak Signal Propagation Reporter (WSPR) using a half-watt of power.

I fastened a pulley to the top of my 12 metre Spiderpole so that with a string through the pulley I could quickly raise and lower alternative dipoles. For several hours each day I changed antennas every half hour. Afterwards I went to the WSPRnet (wsprrnet.org) site and checked the data showing time, stations that had heard me and the signal level they observed for my signal recorded there. Since I knew which times corresponded to which antenna, I could now correlate the signal strengths recorded by distant stations with the antenna that produced them.

I know there are problems with this approach; mainly because the times are different, the propagation could be different too, without having anything to do with the antenna. Nevertheless, I felt that with enough data I could make a better than anecdotal report on the effectiveness of these two antennas.

I looked down the results to find stations that had recorded receiving my signal in all, or just about all, time periods and I noted the signal strengths and antenna used.

As I analyzed these data I often found considerable signal strength variations recorded by the same station within any 30-minute period, but the differences between one 30-minute period and the next were generally slight. That is, if there were variations of six or more dB within a 30-minute period, there were usually variations of six or more dB in the next period, but generally the signal strengths overlapped from one period to the next.



Figure 4: The RF choke; 9 turns of RG-174 wound on a Palomar Engineers FSB1/2 mix 31 clip on core.

I do have repeatable data that support this conclusion.

Since I use these dipoles for portable operation I thought it might also be interesting to see how they compare with my home station doublet that is 40 metres long, about 10 metres high and fed with home-made ladder line. For this comparison I again used WSPR, switching at 30-minute intervals between the doublet and the end-fed dipole. In this comparison, in addition to time differences, there is also the added complication of vertical versus horizontal antenna polarization and lobes on the radiation pattern of the doublet that could be very different from the radiation pattern of the end-fed dipole. I did not find a large difference in performance between the two antennas although I felt that there was a slight advantage to the doublet.

I am pleased with these results. They suggest that in portable operation neither the end-fed dipole nor the resonant feedline dipole represent much, if any, compromise when compared to a modest home station antenna like the one I have. Either antenna is easy to set up in a variety of configurations, and for QRP operation these antennas are small and of light weight.

I built my end-fed antenna in 2011 before David Conn, VE3KL, wrote two excellent articles on end-fed half-wave antennas in his "Antennas & Transmission Lines" column (January-February 2014 and March/April 2014 TCA) so I did not have the benefit of his insights into the construction of the matching transformer or the antenna.

If you are interested in building one of these antennas, in addition to looking at AA5TB's website, I most definitely recommend that you read these columns before you start. I expect it is likely that an end-fed dipole built with these insights would perform better than the one I made.

My experiments with these antennas have left me with some answers but yet more questions which I may have time to experiment with some day. I also have some additional information regarding my dipoles that may be helpful to others experimenting with these types of antennas. Please feel free to contact me at ve7bqo@rac.ca if I can be of assistance.



WA4USN operations desk. This is where control of the vessel would have been switched if the main bridge had battle damage. It is at the bow of the vessel just under the flight deck. When you look out the portholes you realize how high above the water you are. (All photos courtesy of the author)

Southern Amateur Radio Hospitality: N4H and WA4USN Special Events Stations

Ron Walsh, VE3GO

The southern states are known for their hospitality. This is nowhere more evident than in the Amateur Radio community. I have been visiting the Myrtle Beach, South Carolina area for over 20 years and have enjoyed the friendliness of the Amateurs there. I feel I am part of the group there and have enjoyed meeting the Amateurs at breakfast, meetings and events.

Once we were going there for a longer period of time, I joined the Grand Strand Amateur Radio Club and began volunteering to be part of their communications for the Myrtle Beach Marathon. For the past three years I have been in one of the support vans providing assistance to the runners and the event.

Three years ago I was able to start operating from the *USS North Carolina* in Wilmington, North Carolina. We had to come home early this year so I did not get to operate from there but did contact them during the North Carolina QSO Party. You can check out my article "Big Signals, Big Ships" in the May-June 2014 TCA to see what it is like to operate from this battleship. This year I asked if I could join two other operations and was heartily

This article was previously published in the May 2015 issue of *The Spectrum Monitor*. Thanks Ken! For more information visit <http://www.thespectrummonitor.com/>

welcomed. I considered it an honour and a privilege to be allowed to join in both.

N4H

The Trident Amateur Radio Club was going to operate the special event call sign N4H to commemorate the 151st anniversary of the *CSS Hunley* sinking the *USS Housatonic* in Charleston Harbour. I asked if I could possibly join the event and was kindly invited to attend by Tom Lufkin, W4DAX. He provided the details of the operation and directions to the site. As I crossed the H.L. Hunley Bridge, on February 17, between the Isle of Palms and Sullivan's Island, I felt like I was going back into history.

The *Hunley* was the first submarine to sink an enemy vessel, but was unfortunately lost after the engagement. Clive Cussler, famous author and wreck hunter, led an expedition which found the *Hunley*, which in turn led to the eventual raising of this famous vessel. She is now being restored in Charleston. Tom also is part of this restoration group and I hope to attend one of his tours next year. It is a fascinating story and part of the history of the Civil War.

Just as I crossed the bridge, there was a nice park area where the club was setting up their equipment. This was on the inlet where the *Hunley* actually sailed out for its meeting with history. I arrived a bit early, met Tom and joined in the setup of the equipment. I believe that if I am going

to operate I can help set up and was impressed by the organization and efficiency of their portable operation.

First of all we set up a dipole antenna that uses a folding ladder as the centre support. This allows the ladder to be folded up and carried easily in their vehicle. Four ropes anchor the extended ladder and the dipole has supports at each end. The antenna was up in less than 20 minutes and tested out.

The second antenna was a 31-foot vertical antenna. Once again this was set up using extendable poles and a support. I have used one of these before and had good success with it in portable operations. The only difference is that, since some of our portable operations are in rocky areas, I have a welded steel bar in the shape of an "L" which I drive my car wheel over to provide support for the antenna. We used several radials laid on the ground. However, this antenna had a unique feature. The 26-foot, 3-inch radials were arranged on a cross made of PVC pipe which produced a small, square, spiderweb shape (see the photo on the next page).

He had two of these set up at 180 degrees to each other and connected as the ground to the antenna. This produced a small, effective, easily assembled and easily transported counterpoise. It is amazing how a 31-foot piece of wire, a balun and a counterpoise can get great contacts. This makes a very effective

Unique counterpoise for the vertical antenna at the N4H portable set up.

antenna for 40 through 6 metres. I have asked Steve Lamendola, KE4THX, to give me some information on the counterpoise as I want to make one for my antenna. He said you could even make up four of them and mount them at 90-degrees to each other.



The club had all the necessary cables and equipment readily available. We reoriented the vertical to avoid antenna interaction and the extra coax appeared like magic. Their trailer is a U-Haul-like trailer and is very well organized. They have tables on hinges – along the left wall and front – that are raised for operation. It is quite roomy and can hold three operators. They have all the rigs grounded to the trailer and then connect the trailer frame to a ground rod. They also had two tuners for the antennas and a unit so that both the operator and the logger can use earphones while operating the station. A connection to a generator was made and the station was on the air.

Meanwhile, the 2-metre operation was set up in an SUV using 2-metre FM. The statewide linking system allowed many local Amateurs to work the station. I must admit I put a 2-metre contact in the log.

I was asked to operate and was on the 20-metre station for about 90 minutes. I worked many states and several DX countries during that time. The use of the short call N4H and being listed on some DX spotting sites created quite a pileup. It was not uncommon to take several calls at a time and have operators stand by in sequence to work them. I finally had to take a break so as not to hog the operating station. The FT-897 performed well and, since I have one myself, it was good to learn a bit more about the rig.

There was going to be a ceremonial gathering about the *Hunley* that night and several civil war re-enactors began to arrive. I was interested when a cannon was unloaded.

I had a great time talking to the club members, operating the station and learning some new antenna ideas. Since I had to drive back to Myrtle Beach I had to

leave before all the operating was finished. However, the pileup did not stop until the station went QRT.

The Trident Amateur Radio Club was started by Tom, W4DAX, in 1973, to help get novices on the air. They are still helping new and experienced hams get “Radio Active”, as Tom says! I can certainly see how the members can help other Amateurs as they are a friendly, welcoming and informed group. We had one new Amateur show up and he used my radio to make his first contact. He made a VHF contact with N4H to start his logbook.

Tom said he became President three years ago and found the trailer to be in disarray. They instituted a quarterly “Operating Day” where the trailer is taken to a remote location and set up for operation. This has several good results: the equipment in the trailer is in good

operating condition; the club members get familiar with the operation of the radios; and new Amateurs, or Technician class operators, who do not have HF gear, gain experience setting up an HF station. Operating on the HF bands also gives incentive to get a higher class of licence. The *Hunley* event was an extra operating day and was very popular.

Recently, the club put N4H on the air for the Museum Ships event on June 6 and 7. On Field Day, and other events, the club uses N4EE as their call sign. I would be very happy to join them again on one of their events. This time I would like to get some CW operating using the N4H call.

My request for a QSL and operator’s certificate is in the mail and I plan to display them proudly in my station. I want to thank Tom, Steve and all the Trident Club members for allowing me to take part in this operation and learn a lot. I also congratulate them on their interest in new Amateurs. I salute their efforts to get Amateurs active on the air. It is one of my favourite topics at my own local meetings. The frequencies we do not use, we lose! We are operators, so operate!

WA4USN

My operation from the *USS North Carolina* led me to check out the operations aboard the aircraft carrier, *USS Yorktown*, moored at Patriots Point near Charleston, South Carolina. As most readers know, I have an interest in ships and history. The original *Yorktown* was sunk in the famous battle of Midway and this ship, CV-10, carried on her name in the fleet.



This famous “Fighting Lady” was commissioned on April 15, 1943 and fought in many World War II battles. She was the first ship at the Patriots Point Museum and is now joined by the heroic, World War II destroyer, *Laffey*, and the submarine, *Clagamore*.

The latter two ships have been on the Amateur Radio bands as NT4HI and NJ4DU respectively, but operations there are not permitted at the moment.

The Amateur calls reflected their original US Navy call signs of NTHI and NJDU.

Close-up of the carrier *Island* antennas and the WA4USN repeater antenna.

THE OTTAWA AMATEUR RADIO CLUB PRESENTS THE 2015 OTTAWA (CARP) HAMFEST



SATURDAY, SEPTEMBER 12, 2015

(The week after the Labour Day Weekend)

**Commercial Vendor setup: 7:30 am; Private Vendors: 8 am
Fleamarket Open: 9 am until 12 noon**

CARP AGRICULTURAL FAIRGROUNDS

**W Erskine Johnston Arena
3832 Carp Road, Ottawa (Carp), Ontario**

- Next door to the renowned Carp Farmers' Market
- Just Minutes from the Diefenbunker
- Enjoy Scenic Ottawa – Canada's Capital City

*From Ottawa take Highway 417 West to Carp Road exit #144,
10 kilometres North to the fairgrounds.
We are in the W. Erskine Johnson Arena – follow the signs.*

**\$6 general admission
\$14/table (plus admission)**

Ham licence exams on site – get yours or upgrade!

**THE REGION'S LARGEST FLEAMARKET AND
HAMFEST. MAJOR HAM RADIO RETAILERS!
LOTS OF DOORPRIZE DRAWS!**

**Radioworld, Durham Radio, MacFarlane Electronics,
Maple Leaf Communications and more...**

For further information or reservations contact:

Ed, VE3WGO

Email: fleamarket@oarc.net



<http://www.facebook.com/oarc.hamfest>

Website: <http://www.oarc.net/fleamarket>

Talk-in on VE2CRA, 146.94–, 100 Hz



<http://wp.rac.ca/>

The museum is located on the Mount Pleasant side of Charleston Harbour.

It is easy to get to Patriots Point from Highway 17 and I must admit it is quite the impressive sight as you enter the museum grounds. The *Yorktown* really stands out against the background of Charleston, the eight-lane Arthur Ravenel Jr, cable-stayed bridge, Fort Sumter and the Cooper River.

There is a parking charge and I paid an admission to the carrier. I do not mind this as this is how the ships are maintained. I also visited their gift shop which is quite well stocked and priced quite reasonably. The carrier has so many things to see that at least a whole day is needed to take in the vessel. I have to return to see things such as the memorials to the Battle of Midway

**Ron Walsh, VE3GO,
working a pileup
on 20 metres
aboard WA4USN.**



and the famous Doolittle raid. There is also a veteran, 93 years of age, who visits the ship regularly and has flown all the historic aircraft displayed on the vessel. Unfortunately, it was a cold, rainy day and he was not there during my visit. The volunteers on the ships cannot be more helpful in giving information.

I noted that the Charleston Amateur Radio Society operated the call WA4SUN from the carrier. I emailed the club with my background, call sign and dates of visiting the area, and asked if it was possible for a guest to operate the station.

I was contacted by Tom Glaab, AJ4UQ and Jim Comfort, KK4REM. I was kindly told I could operate the station and that a date would be arranged once I got to South Carolina.

I also had a Morse code key that belonged to my father VE3BRK and offered it to the station on the ship. It is now there for all to use. Prior to arrival, I worked Dave, K4SUE, from Charleston, while I was operating the Kingston Amateur Radio Club special call VG3SJAM. This was to commemorate the 200th anniversary of the birth of Canada's first Prime Minister, Sir John A. MacDonald, one of Kingston's most famous residents.

Dave is one of the people who is restoring the original radio room on the carrier as well as being a volunteer on the ship. I had hoped to meet him and see the room but our having to leave the area early has postponed this until next year.

Photos on the WA4USN website show the restoration has been well done.

NWKJ was the carrier's original call and it has been reassigned to the vessel. Military Auxiliary Radio System (MARS) crossband test events use this call now.



Retired carrier *USS Yorktown* on a rainy winter day, complete with vintage aircraft.

I contacted Jim and arranged to visit the ship on February 23. Jim is a Deputy Sheriff so I made sure I could work into his schedule as he was being kind enough to take me on board. It is easy to get directions as the club has a repeater on 146.79 MHz, using WA4USN as its call, located on the top of the island of the carrier.

The ship gets more impressive as you walk along the causeway to the vessel. It was a cold, rainy day but the rain let up while I went on board. I arrived early and talked to the volunteers aboard. The vintage aircraft are really well maintained and displayed. The *Grumman TBF Avenger* and the *B25 Mitchell Bomber* really got my attention.

I met Jim at noon and we proceeded to the Charleston Amateur Radio Society's operation room on the ship. WA4USN is situated in the auxiliary bridge of the vessel. This is where control of the vessel would have been switched if the main bridge had battle damage. It is at the bow of the vessel just under the flight deck. When you look out the portholes you realize how high above the water you are.

A long operating desk has several radio installation ready to hit the air. The room is well organized and well maintained. For antennas they use a Butternut vertical. After all, when you have 900-feet of steel vessel and a couple of miles of salt water in three directions you have the ultimate ground plane.

At 1210, we activated the TS-930S on 14.270 SSB and started to call. The first reply was from Jim, N8IKL, in Akron, Ohio. A solid signal was confirmed and I continued to call CQ. My next contact was George, VE3GHK, who I have known for more years than we wish to remember. Let's just say, we were SWLs in the

1960s. Once it became known that the station was on the air, the pileup began. I guess the WA4USN creates quite a stir on the bands.

We worked 25 states, two Canadian provinces, four European countries and 127 stations overall. At 1305, my brother, VE3KBW, called the ship and we had a contact back home. He also asked me to get him a ball cap from the ship. Who needs the Internet to make a purchase! During the operations we were contacted by four other museum ships: Ray, N3SUB, from the submarine *Becuna*; Fred, W6BSF, from the submarine *Cobia*; Jack, KA3HPM, from the submarine *Requin*, and Larry, W5LEX, from the carrier *USS Lexington*. It was quite a thrill to contact another carrier.

Another friend, Al, VE3ASL, managed to get through the pileup. I even had one mobile and two QRP stations in the log. Three and a half hours later I had to close the station as it was time to eat and head back to Myrtle Beach. I never even got to try CW as the calls just kept coming. Once again, I had to take several calls at once and have them stand by to be worked in sequence. It is nice to be rare DX sometimes!

Jim and I went for a bite to eat and we had quite the discussion about the station. I was invited back to do some night-time operating as I guess the 80 and 40 metre results are just phenomenal. I will surely be back as I want to see this for myself. Jim said it has something to do with the Brewster angle of refraction and their marvelous ground plane. I can't wait to try that out.

I have to thank Tom and Jim for allowing me to operate this station. It is a thrill to operate from an aircraft carrier with that call.

Jim was very generous with his time and I hope he visits my area some time so I can return the favour. It was an honour and a privilege to be aboard this ship as well.

Amateur Radio operators are known as a friendly and helpful group of people. I will certainly try and be as welcoming to other Amateurs visiting my area. Being a volunteer Examiner, I try to return something to our hobby.

If you are interested in operating a special event station ask the people involved. In Kingston, Ontario we have the VE3RCS (Royal Canadian Signals) station at the Communications and Electronics Museum at the Canadian Forces Base. During the day, it can be arranged for this call to be available. In fact, they are rebuilding the ham shack at this time and it should be ready by the summer.

I hope that next spring will bring a chance to operate from the southern United States again. During the year I hope to try my new counterpoise, help the Amateur groups in Kingston and operate CW on Field Day.

I have been an SWL since 1959 and a licensed Amateur since 1976. I was originally VE3IDW and now hold the call VE3GO. I am a retired teacher. I have been a Great Lakes ship enthusiast for over 50 years and hold a Minor Waters Masters certificate. I have retired from running Thousand Island tour boats and working as an officer on the Canadian Empress. Combining my two hobbies with marine photography led to writing for Monitoring Times and now The Spectrum Monitor.



RADIOS THAT HELPED WIN WWII

Frank Gue, VE3GUE

My grin got broader and broader as I read through OM Jerry, VE6TL's, "A Tale of Two Marconi Pairs." 1154/55s were an important part of my life for a couple of years during WWII.

We flew these in Harvard trainers at #2 Wireless School Flying Squadron at Shepard Field, just east of Calgary. The radios and the aircraft were poorly matched. Hundreds of pounds of WT in the back pit of a Harvard puts the centre of gravity well aft of where it should be.

A placard in the front pit warned:

Aerobatics strictly prohibited. This aircraft requires 4,000 feet to recover from a spin.

One night I found the trailing antenna wound around the aft fuselage of one of my Harvards. Now, there is only one way such a thing can happen...

"Sir," I said to the pilot next morning. "Did your student have trouble reeling in the antenna yesterday?"

"Yes," he replied, eyeing me, "Did you write it up?"

"Oh, no, the students are forever ripping off the bob weights that way. I just replaced it."

"Good," he replied, and after a pause, "Is there anything I can do for you?"

"Well, sir, you fly the Ventura to Edmonton every Friday, back Sunday. Could I hitch a ride?"

And that's how a humble WEM (Wireless Electrical Mechanic) got to fly, however briefly, in the cold and drafty mid-upper gunner's position of a medium bomber.

The Air Force trained us for nearly a year in radio theory and radio repair. We ridiculed the American radio techies who knew very little theory and no repair. The Americans, we said, didn't solve problems, they just trampled them to death. But that witticism was unwarranted and unfair, because it was simply a reflection of the US approach to war supplies (throw it away and plug in another one, get that P51 fighter back in the air, there's lots more where that came from); and the British/Canadian approach (we don't have any spares and they can't make them fast enough, repair it and put it back in service). All things considered, under the pressures of war, the US approach was probably better.

Speaking of which, I am looking at three ARC-5 "Command" receivers and their companion transmitter that kept me on the air for several years as VE6BH. They are still operable.

For QST in 1952, I wrote up my conversion of the receivers to two triple superhets, one for 80, the other for 40. They have an 85 kHz 3rd IF which, rendered regenerative by a tiny feedback lead between plate and grid, makes them sharp-as-a-tack selective.

I bought these rigs, brand new in tropical packaging, for \$11 each laid-down in Edmonton. I should have bought 1,000 of them!

The R1155 is an unusual beast. It has elaborate "sense" circuitry that enables the user to determine which of the two directions (180 degrees apart) its loop antenna registers is the correct direction. Its circuit negative is not chassis ground, which requires, among other curious things, a "bias resistor" between circuit negative and the chassis. This resistor is prone to burnout. Locating and replacing it is a good two hours work.

The 1155's huge dial, big tuning knob, and click-stops for a few critical frequencies, made it very easy for the WAG (Wireless Air Gunner) trainees to use both in training and in action. The ARC-5s, excellent as they are, didn't come near this level of ease of use.

One marvels at what is better done today, in an electronics package weighing a few grams; things that required scores of pounds then. I once wrestled a huge 28-volt lead-acid battery out of a Harvard, staggered 100 yards to the wireless lab, and thudded it down on the charging bench.

"What do you weigh?" asked the corporal.

"About 125 pounds."

"Do you know what that battery weighs?"

"No."

"It weighs about 125 pounds. I didn't know you could lift 125 pounds."

A TALE OF TWO MARCONI PAIRS: R1155/T1154

Jerry Spring, VE6TL

The story behind the Marconi R1155/T1154 receiver-transmitter pair is a fascinating one. Traditional lore has it that they were designed on a napkin over lunch and the first units came off the assembly line in record time. The radios provided the primary means of communication for British bombers in WWII, being installed in a variety of aircraft.

After the war, they were stripped from planes and either sent to the trash heap or recycled among the Amateur Radio community for a few dollars each. Some estimate that as many as 80,000 R1155 receivers were built, as each plane was outfitted with two of them. Far fewer: T1154 transmitters were built and they are considered quite rare today. The serial numbers engraved on the front plate are not indicative of the order built or the model number, as the British did not wish to give anything away in terms of production rates or modifications.

My first experience with the R1155 receiver came in 1972, when I was 15 years old and growing up in Windsor, Ontario. I had just met someone at school who was a year older and who had just received his Amateur Radio licence. In those days, you needed to pass the Morse Code test to get your ticket and I was keen on learning. After developing some speed



From left: Jerry, VE6TL, Russ, VE6VK, and Phil, VE6ABW, with Phil's restored gear.

I spent many hours copying their transmissions and managed to get my code up to quite decent speeds and had

An online search showed quite a lot of material on the R1155 receiver. There were numerous articles that dated back to

"Neither did I. And now you've told me, I am quite sure I can't."

72 years later, I sometimes wonder why my spine is often so painful...

Memories that bless and burn, as the old popular song has it. Pity I have no record of the memories of brother Chas, a Lancaster captain, or brother Les, an aero engine mechanic. We should capture such of them as remain.

Frank Gue was licensed in 1946 as VE6BH and later as VE3DPC and now VE3GUE. He spent three years as a Wireless Electrical Mechanic in the Royal Canadian Air Force (RCAF) and later took Electronics and Master of Business degrees. He has written numerous articles, handbooks, and texts on electronics, aerodynamics, education, factory management and politics. He lives in Burlington, Ontario.



Licensed at least 25 years ago
and licensed today?

Then you should join the
Quarter Century Wireless
Association, Inc.

To Join or Renew visit:

<http://www.qcwa.org/join-renew.php>

For more information please contact
gm@qcwa.org



Phillip Boucher, VE3BOC
E: phillipboucher@gmail.com
www.phillipboucher.com

FRESH ON THE AIR

– ADVENTURES FOR THE NEW AND BEGINNING HAM

– All Manners of Manners...

In recent conversations

with some new Amateur operators, a common theme that they wish to discuss is the various inappropriate communications that take place on the air, and some operators' behaviour towards new Amateurs. Since these seem to be recurring issues, I think it's time to look at them again.

Examples of inappropriate communications on the air include a discussion about an operator's *extremely* personal life, and also other topics that should be regulated to more private venues such as in the corners of one's home or via email or text.

Is it really appropriate for other Amateurs on a frequency – or especially a repeater – to hear John talk about his recent operation where they removed 15 tumours from his leg but it got infected and they had to cut it open – you get the gist.

Or Frank complaining about the insurance company that shafted him over and over, with higher and higher rates because he kept getting into accidents which were always his fault? Or Jimmy and Kyle discussing Fred's recent divorce and all the dirt and hatred and cheating behind it?

Let's face it. These types of intimate personal conversations do not belong on the Amateur Radio airwaves at all.

They are inappropriate for anyone to listen to and are especially off-putting to any new ham who happens upon this type of QSO. Our job is to bring new blood into the hobby, not scare them away. Please exercise discretion and leave these types of topics off the air.

Now, unfortunately, there are many stories of new Amateurs who have had the unpleasant experience of not being welcomed into their local Amateur Radio community. They go onto a repeater and try to join in the conversation but are ignored. Some Amateurs, once they discover the other ham is a newbie, abruptly end the contact. It seems like some experienced hams treat new hams as if they were not *worthy* of joining the hobby – let alone joining in on a conversation on a repeater – until they have proved themselves to be worthy of such through some invisible and unknown act of Amateur Radio miracleism.

As Amateur Radio operators, we are supposed to be professional in our conduct on the air and with each other. Being Amateurs does not make us *amateurs!* Common courtesy and our professional conduct is one of the reasons we are utilized by public service agencies in emergencies. To keep our reputation intact, it is imperative that both *new and experienced* Amateurs take the following rules to heart:

RULES FOR NEW HAMS

1) Listen Before You Transmit: I can't stress this enough. Listen to the conversation before you try to join it. Listen more. Then, listen some more. Then listen so you can gather a good understanding of how the contacts work on the frequency or repeater: what the protocols are for joining a contact in progress; how to let those monitoring the repeater you are available for a QSO; and how transmissions are handed off to each Amateur. When you've listened way more than you could ever talk, wait for a lull in the conversation and then *politely* ask if you can join the QSO. Remember, you're the new guy or girl here. Show courtesy and respect.

2) Be a Good Operator: follow the rules, regulations and general Gentlemen's Agreements when on the air. Don't be suckered into the bad operating habits some of the more experienced hams have developed. Your purpose is to grow and progress in our hobby. The only way to do that is to do everything as expected.

3) Learn, Educate Yourself and Experiment: Always be willing to keep up with changes in the rules and regulations, new technology affecting Amateur Radio, and try new things in the hobby that interest you. By doing this you

will be able to hone your skills and knowledge and gain that unknown and invisible "miracle thing" that will get you the respect and acceptance from the "more elite and very experienced" Amateurs.

RULES FOR EXPERIENCED HAMS

1) Be Humble: just because you're experienced doesn't mean you are the bee's knees, Ruler of the Radio or King Shitzu. Experienced means you have lots to teach and to mentor to the newer members of our hobby.

2) Be Courteous and Polite: remember, your behaviour towards new hams directly influences whether they will stay in or abandon the hobby.

3) Be Selective with Topics: Amateur Radio is a hobby that is intended to promote and progress the technology and use of two-way radio. Very personal topics really have no place over the airwaves. Keep these topics to the realm of landlines, emails and text messages.

4) Leave Room Between Transmissions: Pause for five to 10 seconds between transmissions at times to allow any new Amateur on the frequency the chance to key up and ask to join in the QSO.

5) You Never Know Who's Listening: Just like most cell and cordless phone users who think that no one can hear their private conversations, some experienced hams think that only other Amateur Radio operators can hear us on our frequencies and repeaters. Not so by a longshot. Many radio hobbyists, potential new Amateurs and public service officials are listening to our repeaters, our frequencies and our QSOs, and what they hear is reflective of how they perceive us to be. If they encounter rude behaviour, nasty operators or language that is not reflective of the level of professionalism expected in our hobby, then they are going to continue to perceive us as idiots, creepy old geeks and young girlfriendless nerds – perceptions that we are trying to avoid. Be wary that what you say and how you act on the air is not limited to being heard just within the Amateur Radio Service.

We are all in this together, and being a helping, mentoring, and professional community of men, women, and young people is how others should perceive us all the time.

Transmission Tidbit:

Celebrity Hams: Country singer Patty Loveless KD4WUJ; Eagles member Joe Walsh WB6ACU

Write me via the magazine; email me at phillipboucher@gmail.com or via my website at <http://www.phillipboucher.com>.

RAC MEMBERSHIP / ADHÉSION À RAC

Exclusive RAC membership



Maple Leaf Operator Membership

Paul Allen, VA3PB
 Vincent Amyotte, VA5NEE
 Keith Antonelli, VE7EXH
 Adam Aultman, VA3AUL
 Michael Aultman, VA3MPR
 Gary Badcock, VO1GWC
 Peter Baker, VE3OCN
 Dennis Bancesco, VE6ATC
 Doug Bannard, VE3SPF
 Shawn Barnard, VE3KYQ
 David Barnes, VO1YA
 Bill Barrie, VE3AAS
 Douglas Barry, VE7WLF
 Geoff Bawden, VE4BAW
 Michael Bell, VE3NOO
 Michael Belliveau, VE6XMZ
 Larry Berta, VE3LXV
 Serge Bertuzzo, VA3SB
 Brian Biggings, VE3XA
 Christian Bisailion, VE3CBK
 Bill Boskwick, VE4BOZ
 Allan Boyd, VE3AJB
 Harold Braun, VE3CD
 Patrick Brewer, VE3KJQ
 Michael Brickell, VE3TKI
 Ronald Brook, VE4RON
 Mike Brown, VA3GRL
 O Ernest Brown, VA3OEB
 Matthew Brown, VE3EB
 Vern Brownell, VE7MCC
 P Buckway, VY1PJB
 Ian Burgess, VA6EMS
 Paul Burggraaf, VO1PRB
 Rick Burke, VO1SA
 William Bush, VE3BXI
 Gary Butler, VE7OQ
 David Caddell, VA7VVV
 Fred Cain, VE3JMJ
 John (Jack) Cain, VE7DBK
 Sandy Cameron, VE3AAC
 Ralph Cameron, VE3BBM
 Mark Capewell, VA7MNV
 Mary Card, VE3FEB
 Jeffrey Cederwall, VE3JTD
 Gilles Chevalier, VA2CG
 John Christensen, VE3IAO
 Geoff Clarke, VE3JBD
 David Clarke, VE6LX
 Ken Clarke, VE7BC
 Edmondo Conetta, VA3ITA
 John Connor, VE3TG
 Guy Costanzo, VA7GAC
 K James Couprie, VE6IG
 Donald Courcy, VE1SS
 David Coutts, VE3KLX
 Robert Cove, VO1REC

RAC MAPLE LEAF OPERATOR MEMBERSHIP / ADHÉSION À "OPÉRATEURS MAPLE LEAF" DE RAC

Chris Cowx, VA7CWX
 Paul Cragg, VE3AXT
 William Cunliffe, VA3WRC
 Francois Daigneault, VE2AAY
 Renze Dam, VE6DC
 Rick Danby, VE3BK
 James Davidson, VE3TPZ
 Brian Davies, VE6CKC
 George Davis, VE3OGP
 Frank Davis, VO1HP
 Julio Diaz, VA3JCL
 Richard Dion, VE3LAD
 Grant Dixon, VE3CGV
 Tom Dobson, VE3TWD
 Michael Drake, VA3BKQ
 Ian Drinkwater, VA3UM
 George Duffield, VE3WKJ
 Robert Dyer, VE3KTY
 David Easingwood, VE7DPE
 Tim Ellam, VE6SH
 Doug Elliott, VA3DAE
 Edward Evanko, VE4EDE
 David Evans, VE6DXX
 Alan Farmaner, VA3AVF
 Russell Farrell, VE3ELL
 Michael Fearn, VE7MWH
 Thomas Feeney, VE3KTP
 Richard Ferch, VE3KI
 Terry Finn, VE6TF
 James Fisher, VE1JF
 Tony Fonseca, VA7TF
 L Fowler, VE3NPC
 J Frame, VE3JDF
 Richard Francis, VE3OXX
 Edward Frazer, VE7EF
 Norm Freidin, VE3CZI
 Mario Gasparovic, VE3HVY
 David Gerrard, VE3VID
 Gordon Gibson, VE3NQK
 Ross Gibson, VE4RWG
 Paul Giffin, VE7IPM
 John Gilje, VE6KJG
 Dave Gillis, VE7BX
 Thomas Godden, VE3TWG
 Jean-Pierre Goode, VE2BDG
 Mitchell Goodjohn, VE6SM
 Stephen Goodwin, VE6SMG
 Dave Goodwin, VO1AU
 Larry Gorman, VE3LGN
 George Gorsline, VE3YV
 Gregory Grant, VA7GRA
 Ron Griese, VE3RJG
 Dominic Grosleau, VE3DGZ
 Reg Gulliford, VE3AWN
 James Gunter, VE6JRG
 Tom Haavisto, VE3CX
 D.A. (Sandy) Haggart, VE3HAZ
 Colin Haig, VE3MSC
 Don Hamilton, VA7GL
 David Hamilton, VE6DWH
 Gordon Hamilton, VE7ON
 Garry Hammond, VE3GHP
 Garry V. Hammond, VE3XN
 Richard Hanishewski, VE5RH
 Martin Hann, VE9PLS
 Brad Harris, VE3MXJ

Sheldon Hartling, VE1GPY
 Derek Hay, VE4HAY
 Harm Hazeu, VE4HAZ
 Margaret Heaslip, VE3EQE
 Peter Hebb, VE1SM
 Jean Henault, VE2JHP
 Richard Henderson, VA6RIC
 Hugh Henderson, VY1HH
 Peter Henry, VA3PWH
 Doug Henry, VE4TG
 Howard Hepburn, VE6GT
 William Hicks, VA6RQ
 Dallas Hinton, VE7FKH
 James Hodgson, VE3HOV
 Peter Hodgson, VE3UR
 G. Hollett, VE1MLW
 Henry Hollinger, VA6HBY
 Alison Honsberger, VE3GRL
 Joseph Hopkins, VE7BYF
 Clare Hopkins, VE7IBK
 David Hopkinson, VA7FTW
 Gabor Horvath, VE7DXG
 Robert (Bob) Howard, VE3YX
 A Graham Ide, VE3BYT
 Robert Ireland, VE9KM
 Lorne Jackson, VE3CXT
 Gordon Jacques, VA3GJJ
 Peter Jago, VA3PJ
 Gordon Jewsbury, VE4OK
 Doug Johns, VA3DLJ
 Scott Johnston, VA3CCU
 Walter Johnston, VE3GE
 Sam Jones, VE3LCK
 Dale Jones, VE7JP
 Ernie Jury, VE3EJJ
 W.J. Karle, VE1YY
 Eric Kehler, VE7EGK
 Ernest Kenward, VE7BYK
 Stephen Kerridge, VE7XPL
 Robert King, VA7DX
 David Kingsland, VE3MDX
 Bill Kirby, VO1BB
 David Klatt, VE5GN
 Walter Kohler, VE7SM
 Boris Kohut, VE4BG
 Gordon Kosmenko, VE6SV
 David LaHay, VE7FVW
 Jason Lapierre, VE6TMR
 Benoit Laprade, VE2LSF
 Harvey Larabee, VA3LHA
 Doug Leach, VE3XK
 John Lediett, VE3FVC
 Barrie Lennox, VE3AOI
 Stan Leschinsky, VE3TW
 Joel Levis, VE3CJJ
 Scott Lightfoot, VE4STL
 John Lockwood, VE9KC
 Gerald Lutley, VE1GPL
 Rand Lutman, VE7HRA
 Glenn MacDonell, VE3XRA
 Ian MacFarquhar, VE9IM
 John MacKay, VE7EEX
 Robert MacKenzie, VA3RKM
 Jim MacKenzie, VE5EIS
 Neil Macklem, VE3SST

Daniel Madden, VA3RRJ
 Pierre Mainville, VA3PM
 Alan Mallett, VA7AWM
 Eric Manning, VA7DZ
 Matthew Martyn, VA3MWM
 Greg Mason, VE4AMN
 Martin Matheson, VE6GE
 Gabriel Mazzeo, VA3CWT
 Philip McBride, VA3QR
 Don McCallan, VA3GFD
 Duncan McCansh, VE3OM
 Bernard McCoy, VE6HFD
 Ghislain Jacques McGraw, VE6GJJ
 David McKinlay, VA3IR
 L. Dave McLennon, VO1LM
 Malcolm McLeod, VE5ZG
 Chris McMullan, VA3CMJ
 Doug Mercer, VO1DTM
 G Rick Michowicz, VE3TYP
 Eric Mills, VE1AST
 Micheal Misiwich, VA6MIS
 J.T. Mitchell, VE6OH
 Lenard Moen, VA3HBR
 Marcel Mongeon, VA3DDD
 Byron Morse, VA3BMO
 Bob Morton, VE3BFM
 Wilfried Mulder, VE7OHM
 Garry Naylor, VE6FGN
 Jim Nelson, VE6ACR
 Albert Nelson, VE7WC
 Patricia Nordin, VE3ZP
 Brett North, VO1BBN
 Rick Norwood, VA3EJN
 Stephen Olesen, VE6SLP
 Keith Olson, VE4VO
 Dennis Paganin, VA3DTP
 James Park, VE7IW
 Bill Parker, VE1VP
 Joseph Parkinson, VE3JG
 Gordon Passmore, VA7GAP
 Brad Paterson, VA6AKF
 Colin Pavey, VA3FP
 Geddie Pawlowski, VE3CJX
 Doug Peckhover, VE3ATP
 Johan Pedersen, VE0NLI
 Tim Pekkonen, VE3UO
 Steve Pengelly, VE3STV
 Mark Perren, VE6IHS
 Brent Petersen, VE9EX
 Ron Philip, VE7NS
 Murray Pierce, VE3IFP
 Robert Piggott, VE7CYU
 Dale Pilsworth, VE6DAP
 Gary Pollock, VA3GMP
 Harold Porter, VO1JA
 Terry Potts, VE3TEP
 John Potts, VE6JWP
 Everett Price, VO1DK
 Tim Pychyl, VA3PYC
 Devon Racicot, VE5DWR
 Marty Raine, VE1AE
 Norm Rashleigh, VE3LC
 Bryan Rawlings, VE3QN
 Steve Regan, VA3MGY
 Gilles Renucci, VE2TZT



Radioworld

ICOM

KENWOOD

RFinder

The Worldwide Repeater Directory
www.r-finder.net

YouKits

Earl Richardet, VE7QJ
Dennis Ritchie, VE3DXZ
Ed Roberts, VE3KSW
Cameron Rodger, VE4CDR
Peter Rogers, VE3ETR
Allan Ross, VE7WJ
Donald Rowed, VE3KII
Mark Sales, VE6VER
Edward Samborski, VE3TAS
Dan Sanchez, VE7EOZ
Brian Sayer, VA6BCS
Bill Scholey, VE7QC
John Scott, VE1JS
David Scott, VE3ZZU
Ian Seddon, VE3HUT
Ellis Seddon, VE4AJO
Ian Shaw, VE3IJS
Bill Sheldrick, VE6ILE
Kieran Shepherd, VA3KS
Robert Shkuratoff, VA7DIV
Chad Shoaf, VA6TT
George Simpson, VE6HX
Ron Sinclair, VE3JRN
Gary Skett, VE7AS
Thor Skotar, VE3GXV
Dave Snyder, VE4XN
Patrick Speer, VE7PJS
Mark Spencer, VE7AFZ
Mike Stafford, VE6MEX
Noel St-Amand, VA3TS
Rob Steenweg, VE1CHW
Al Stephens, VE3NXP
Jeff Stewart, VA3WXM
Jack Summers, VA3XR
Ivan Taverner, VE6RC
Jim Thiessen, VA3KV
Jason Timmis, VE7AG
Yori Tsuji, VE4ACX
Ian Turnbull, VE7TGI
Al Tyson, VE3EXE
W.L. Underwood, VE1WLU
Bill Unger, VE3XT
Ronald Vadeboncoeur, VE3REV
A Vaillancourt, VE3DPZ
Bernie Van Tighem, VE7BVT
Alex Vandermeij, VE3LEX
Robert Vanderminnen, VA3RMV
Marinus Vanderminnen, VA6OPA
Maurice-André Vigneault, VE3VIG
Ron Vollick, VE3GGX
Andrew Webb, VE6EN
Albert Webber, VE4AMW
Joel Weder, VE6EI
Andrew Wells, VE3WEL
Ralph Welsh, VE3RWO

Garth Wetherall, VE3YC
John White, VA7JW
Kyle White, VE5KW
Brice Wightman, VE3EDR
James Wilkins, VE7UJL
Stan Williams, VA7NF
Ken Williams, VE9KW
Wayne Willis, VE5WFW
Bruce Winter, VE7HBW
John Wiseman, VE7BVS
K Wood, VE1QD
Allen Wootton, VE7BQO
James Wyse, VO1CPZ

**NEW RAC MEMBERS
NOUVEAUX MEMBRES RAC**

Arthur Abramovitch, VE3GFB
Michael Addison, VA3GBY
Laith Almusa
Sonja Andersson, VA7SAA
Kosta Arvanitis, VE7KCY
Roland Aubin, VA2JWZ
Paul Baker, VE7PBE
Bradley Balla, VE6CTX
Paul Barnett, VA6TTX
Ron Bilinsky, VA7RTB
Steve Blatch, VA3SGB
Jeffrey Bondy, VE6MRN
Ian Boughton, VE4ILB
John Brent, VA7WPN
Sean Bridge, VE1XOP
Jeffrey Brown, VA3XUK
John Bucchieri, VA7JPB
Thomas Andrew Buchanan, VE6ARG
Hugues Bujold, VE9BUJ
William Burrows, VE7WRB
Jorge Cabrita, VA3IPG
Enrique Canto, VA6ICY
Philip Wayne Carter, VA3AOQ
Dave Cason, VE6DED
Michael Cassidy, VE6MJC
Yi Jun Chen, VE3GXN
Adrian Ciuperca, KO8SCA
Richard Cork, VE3RCQ
Geoffrey Cormack, ZS6KJ
Gloria Counsell, VE3EOP
Luc Cousineau, VA3LDC
Jean-Pierre Couture, VE2TLH
Arthur Cramer, VE4ACM
Herman Daigle, VA3UFC
Bruce Davie, VA7BDC
René De Grandmont, VA2KRD
Dave Devine, VE6DEV
Harmanjit Dhillon, VA3HSD
Lorraine Dong, VA3LIV

Steve Drapeau, VA2SKP
Peter Edmonds, VE3SAK
Cameron Edwards, VA7CEG
Richard F Ellison, VE7TB
John Evelyn, VA3JE
Gordon Favelle, VE4FYR
Mathew Fells, VA3BQM
Robert Fortier, VA6FOR
Christopher Fortier, VE6NCR
Anthony Gaudet, VA7GAU
Robert Geddes, VE3UTA
Robert Gillespie, VE3BHN
Lyle Green, VE7VJ
Jason Greenham, VA3JLG
Tomasz Gregorski, VA3WBA
Stan Hack, VE7HSW
Winston Hall, VE6WDH
Jack Harris, VA5JAC
Stephen Hayward, VE9HW
Gregory Henderson, VE7GIH
Andrew Hogg, VA6AMH
Wolfgang Holzmann, VA7CTT
Harold Huard, VA2MGA
Leonard Hyatt, VE6LAH
Sinisa Jezdic, VA3YU
Oliver Johns, W6ODJ
Richard Johns, VA3CGI
Mark Johnson, VE6MMM
Peter Johnson, VE4PTR
Patrick Kerr, VA3NEW
Kyle Klein, VE3KKF
Aaron Kozak, VE6TEX
Jean-Guy Lachance, VE2GON
Daniel Lafrance, VA2ZDL
Michel Lefebvre-Gauthier, VE2MWE
Barbara Lightfoot, VA7CFX
Pui Lui, VE7HKV
Ross Macdonald, VA7SVT
Daniel Mandryk, VE6VX
Bruce Marshall, VA6BRM
Alain Martel, VE2VMS
Tim Marushak, VE5TWM
William Mayberry, VE4WJM
Barry McCoubrey, VE6BRJ
Hugh McCully, VE3AYR
Davic McGrath, VA3DMZ
Alex McLennan, VE7MCL
Alexander McLeod, VE3AHF
Al McNeil, VE7BJA
Alexander Michaels, VA7CDE
Ryan Michaelson, KB1YTR
Paul Milawski, VE3CSY
Aleksandar Milenovic, VA3AXM
James Mojelsky, VE4GTX
John Nash, VE7ODE

David Nelson, VE5DT
Kam Ng, VE6NGK
Sandro Nitoi, VE7NY
Wayne Noel, VA6WSN
Jennifer O'Neil, VA3KNX
Stephen Orr, VE3EZ
Steve Partington, VE3YOM
Kim Paterson, VE7XTT
Kevin Pausche, VE7KWP
Monique Pettitt, VE3PRL
Claude Poitras, VE6CPJ
André Poitras, VE3LTY
Murphy Pottage, VE7MEN
Daniel Prévost, VE2YDP
Darren Ratcliffe, VA6DWR
Archie Reid, VA3CNB
Pierre Richards, VA2JWP
Bradley Rigler, VA7ZBR
Charles Robitaille, VE2RFI
George Roman, VE3KYY
Robert Ross, VE7RFZ
H. Greg Ross, VE1HGR
Benson Sanders, VE3OEH
Ryan Santin, VA7RDI
Ronald Schindler, VE3DXI
George Scott, VE4GWS
Bob Seaborn, VE5XEF
Hugh Shatz, VE3PIA
David Shindler, VA3IIF
Tim Smalley, VE7CXA
Sean Smith, VE6TSF
Jeffrey Spencer, VA2DIF
Frank Statham, VE7VAZ
Robert Stewart, VE3ESC
Michael Strange, WA2BHB
Frank Sved, VE3GID
Lawrence Sweet, WA5TVO
Thomas Tenney, W8OJM
Joel Thurtell, K8PSV
John Timmers, VE7JBT
Ernest Tobias, VA6SVT
Ken Tucker, VO1KVT
Ken Turnbull, VE7CJF
Rob Van Hooren, VE3GOV
Aubrey Vincent, VO1ARV
Joel Vodden, VE4JRV
Andrew Walker, VA7YAA
Scott Walsh, VA7SKW
Don Whitty, VE9XX
Rick Willems, VE3JCU
Jeanne Wilson, VA7QLT
Chad Wiseman, VO2CEW
Robert Yang, VA7RTY
Gerald Young, VE6OSO
Gerald Zarnett, VE3LIQ

The radio... YAESU

HF/50MHz 100W Transceiver

FTDX 1200

This medium-price HF Transceiver Excels on all fronts. The High Frequency Design Technology it has inherited, ensures "Best in Class Performance".
The Outstanding Operability is Perfect for the DX Scene.



Superior triple conversion receiver, and optimum gain distribution at each IF stage will eliminate out of band unwanted signals.

The 1st IF frequency is set at 40 MHz and is protected by selectable 3 kHz, 6 kHz and 15 kHz roofing filters, which effectively attenuate interfering signals.

Similar to the high end series Yaesu transceivers, it uses the 32-bit high speed floating point DSP, TMS320C6727B by Texas Instruments, for its IF DSP.

The acclaimed superior Yaesu DSP algorithm is highly effective in weak signal processing and enhancement.

The Full Color, 4.3 inch TFT display on the left side of the front panel, has a wide viewing angle and provides excellent visibility. It beautifully displays the various functions unique to this high class HF transceiver.

An optional built-in FFT-UNIT supports advanced functionality, including the AF-FFT Scope, RTTY/PSK31 Encode/Decode, CW Decode and CW Auto Zero-in.



The Full Color 4.3 inch TFT display

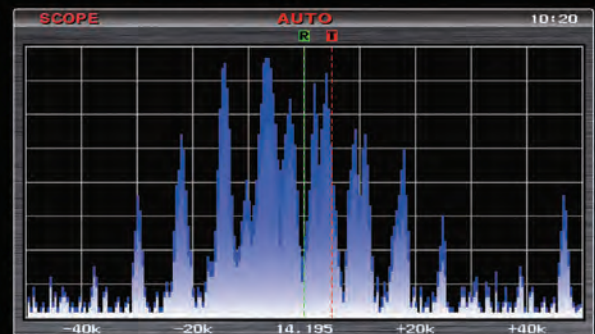

Spectrum-Scope (Full Screen display)

For latest Yaesu news, visit us on the Internet:
<http://www.yaesu.com>

A QRP POWER METER

Tom Hardy, VE4AKI

One of the requirements in operating QRP is accurately measuring your power output. Most modern transceivers with built-in power meters are not accurate enough at powers of five watts and less. This problem also exists with many external power meters. Many do not have a low enough power range to allow accurate setting at QRP power levels.

The following project is an inexpensive, easy to build and easy to calibrate instrument that solves this problem. The meter described here will provide reasonable accuracy for QRP levels from 0.1 watts to five watts.

The most expensive component is the meter movement. A micro ammeter in the range of 50 μ A to 1 mA is required. This could be purchased new but a less expensive source is a fleamarket or another Amateur's junkbox.

Many meters of various styles are available at low prices. Any style will do, but preferably one with a removable face. The other major part is the enclosure. Any metal enclosure (new or used) that can accommodate the meter is suitable.

Let's take a look at the schematic shown in Figure 1 and see what's involved. The RF is absorbed by the load resistance R1. For the five-watt level this can be three 150 ohm, two-watt non-inductive resistors in parallel. This will handle six watts continuous and probably double that on an intermittent basis.

RF is rectified by D1, an IN34 diode. The DC that results is fed to the meter through R2 which is used to calibrate the meter.

The value of this resistor will depend on the range of the meter you are using. I suggest a small trim pot be used to set the full scale reading on the meter.

On the meter I built I used a 1 mA meter (see Figure 2). I found that a 50 k ohm trim pot allowed me to set a full scale reading of the meter to five watts.

The .01 μ F disc ceramic capacitor and RF choke are used to filter any RF out before it reaches

Figure 1: Schematic diagram

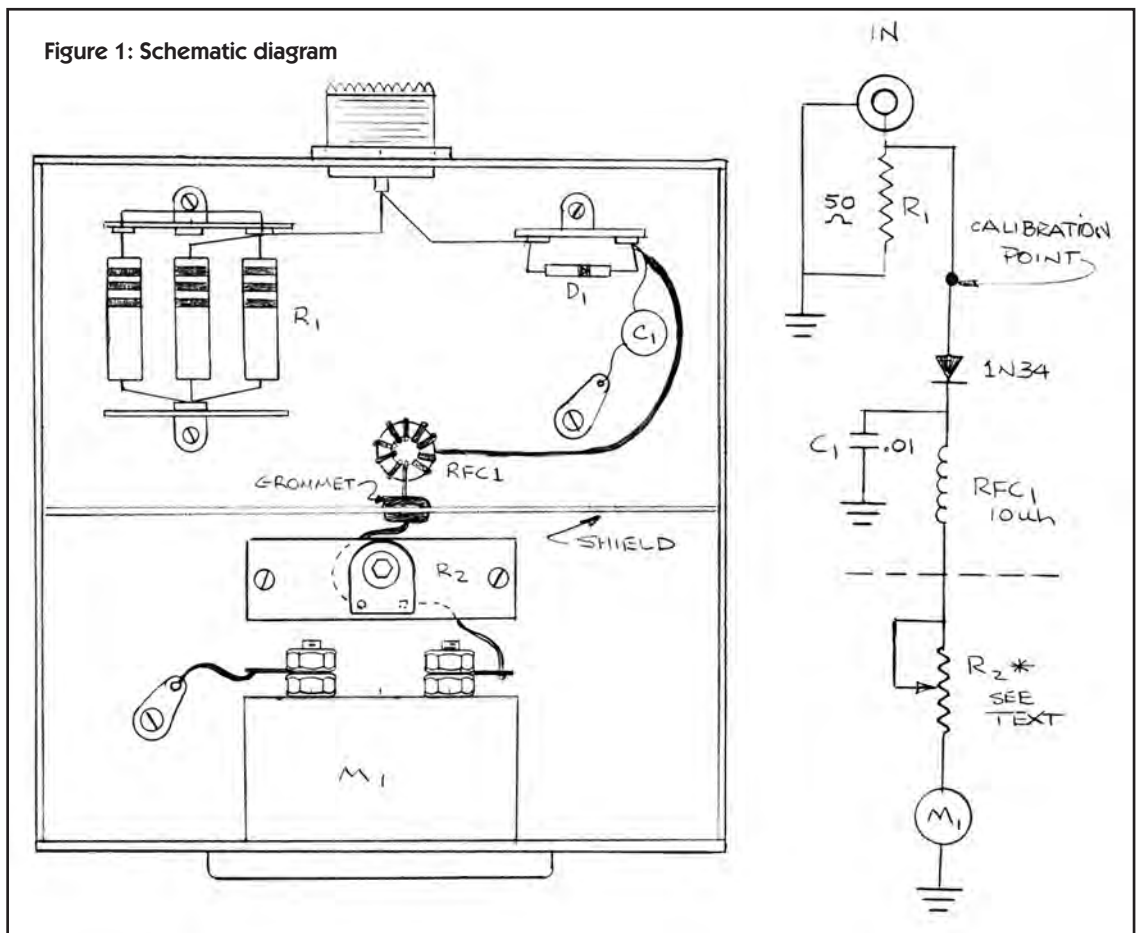

the meter. The choke I used was made by winding about 10 turns of #28 wire on a small ferrite core. Any RF choke in the range of 10-20 μ H should do.

The above diagram shows a suggested layout. The dashed line in the diagram is a shield that isolates the load resistor from the meter.



The size of the enclosure will be determined by the size of the meter you use.

Point-to-point wiring can be used for R1, D1 and C1. An RF connector of your choice can be mounted on the rear panel. A small hole in the shield allows an insulated wire to bring DC to the meter circuit.

Figure 2: The QRP power meter I built using the enclosure and meter from a Heathkit Lab meter.

The RF choke and trim pot can be mounted in a small piece of perf board and mounted to the bottom of the enclosure.

Make sure all ground connections are secure.

The last step is to calibrate the meter. This requires a variable DC voltage source (i.e., a power supply), and an accurate voltmeter (with a digital readout if possible).

Disconnect the diode at the R1 end and feed in the DC voltage to the meter.

Table 1 above shows the DC voltage/watts relationship.

With a DC voltage of 22.78, adjust R2 to get a full scale reading on the meter. This is the five-watt level. Set the voltage to 20.38 and mark the meter scale or note the meter reading. This is the four-watt level. Continue calibrating each step down to the 0.1-watt level. That's all the adjustment necessary.

Don't forget to resolder the diode. A new meter scale can be made up and put over the existing one or the existing scale can be relabeled. If the face of your meter cannot be removed, you may make up a chart to know what the wattage values are.

You will find that the higher power values are spaced closer together while the lower values are spaced out. This allows more accurate reading of the lower values.

Accuracy with a good meter should be approximately 5%-10%.

The meter was intended for use on all the HF bands and I have used it on 40m, 30m, 20m and 17m as these are the bands I use for most of my QRP activity.

Well that's it. Get busy sourcing the parts. Don't forget the shield between the load resistor and the meter. Beg or borrow an adjustable voltage source and find a free Saturday afternoon and you will be on the air by Saturday night.

See you on the bands.

Tom Hardy, VE4AKI, lives in Winnipeg and is a retired vocational teacher who has been a licensed Amateur for 30 years. He holds an Advanced class licence and is active on all the HF bands as well as 6 metres. He has been involved in QRP activity for over 20 years, both CW as well as SSB.

"I enjoy designing and building all kinds of ham equipment especially antennas. I live on a small city lot and am currently concentrating on limited space antennas."

TABLE 1: QRP POWER METER	
Watts	Voltage
5	22.78
4	20.38
3	17.65
2	14.40
1	10.19
.9	9.67
.8	9.11
.7	8.52
.6	7.89
.5	7.20
.2	4.56
.1	3.22



COAX PUBLICATIONS INC

Study Guides

Basic, Advanced, or Instructor, we have them all!

Basic Qualification:
The Canadian Amateur Radio Basic Qualification Study Guide

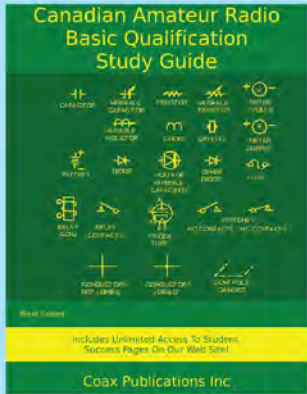

- New 9th edition.
- Updated to the current (2014) Industry Canada exam bank.
- This book is the most widely used study guide in Canadian Amateur Radio classes.

\$44.95 + shipping and taxes

Advanced Qualification:
The Canadian Amateur Radio Advanced Qualification Study Guide

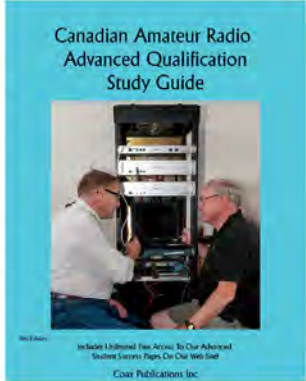

- Updated to the current (2014) IC exam bank.
- Covers many topics in modern communications that are not in the IC Question Bank.
- We have included the small amount of additional material required to match the IC 2014 update in the online Student Success Pages

\$44.95 + shipping and taxes

All of our study guides feature:

- Unlimited Access to our acclaimed Student Success Pages on our web site
- Strong Lie Flat Binding – the book will stay where you opened it when on a flat surface
- Contextual material that goes far beyond the bare requirements of the IC examination

CLEARANCE: while supplies last the 8th edition of the Basic Qualification Study Guide is available for \$22.50 plus shipping and taxes. This edition includes all material necessary to pass the Amateur Basic Qualification examination when combined with the additional material in the Student Success Pages and Ask The Professor Help.

Basic Qualification Instructors' Guide
Download \$13.99 + taxes

Order From Our Web Site
<http://www.coaxpublications.ca>



All Things Digital

Amateur Radio for the 21st Century

019

Robert C. Mazur, VA3ROM

E: va3rom@gmail.com

W: <http://www.va3rom.com>



AN ARDUINO DCR-SDR PROJECT: PART 2

Note: Portions of this column appeared in the November-December 2013 issue of TCA in my column "The Weak Signal Propagation Reporter: Part 2".

INTRODUCTION

Part 1 of this column (March-April 2015 TCA) covered the basic theory and construction of a direct conversion receiver (DCR). In Part 2, we'll add an Arduino Uno and supporting hardware/software to complete this gadget. Simplified technical explanations and diagrams are used to make concepts easier to follow.

Special thanks to Paul Darlington, MOXPB and David Mills, G7UVW, for their invaluable assistance. Several Arduino programs, high-resolution and full-colour diagrams/schematics, parts list and additional material are available from my website.

DIRECT DIGITAL SYNTHESIS (DDS)

In a nutshell, DDS generates audio or radio frequencies (AF or RF) by the mathematical manipulation of a "master" frequency.

In order for our DCR to demodulate incoming radio signals, it needs a second RF source called the local oscillator (LO) to "beat" or mix with them to produce an AF signal (the difference), which is fed into a computing device's soundcard for the digital signal processing (DSP) software to decode and display (text, sound and/or images). Our LO is built around the very popular and easy to use AD9850 DDS module (see Figure 1), which generates RF sine/square waves from 1 Hz to 40 MHz (most can tune higher but...).

GENERIC DDS STRUCTURE AND OPERATION

A typical DDS block diagram is provided in Figure 2 on the next page.

1) A crystal-controlled, master clock oscillator (MCO) from which all other frequencies are derived (synthesized) as some fraction thereof. The theoretical maximum or Nyquist frequency is one-half the master clock frequency.

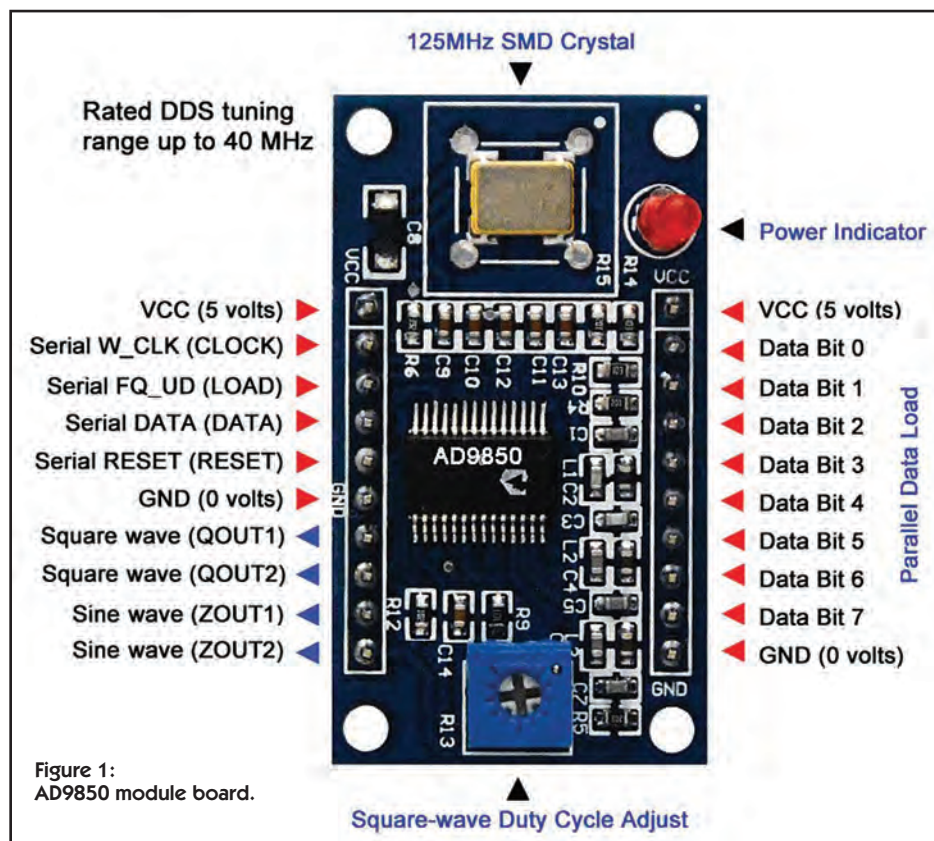

2) A frequency-controlled register (FCR) to mathematically convert the requested frequency from decimal to a binary (digital) 32-bit "tuning word". Actually, 40 bits are used with 8 reserved for signal phase, power down control and (data) loading method (serial/1-bit at a time or parallel/8-bits at a time).

3) A numerically controlled oscillator (NCO) consisting of a phase accumulator (adder) and in-memory lookup sine table (usually 14-bit or 16384 values).

4) A digital-to-analog converter (DAC) to convert digital output into a "real-world" analog sinusoidal wave (the AD9850 uses 10-bit DAC).

5) A low-pass filter (LPF) to smooth the analog signal and remove harmonics (to a certain point), but with a big "but"

because secondary/unwanted images called "aliases" ("aliasing") increase with increasing frequency (especially noticeable above 20 MHz for the AD9850).

DDS CAVEATS

Note: The exact frequency we want is usually not the one generated by a DDS module unless it has been calibrated against a reference signal at a constant voltage and temperature.

A stable, well-filtered, 9-12 volt DC power source (or battery) using short (< 1 metre) leads is preferable because the DDS MCO is supply voltage (Vcc) sensitive and even a plus/minus 0.1 volt change will shift frequencies up/down. Except for programming your MCU, don't use USB (or AC/DC "wallwarts") to power any RF devices because these produce RF "hash" (or have AC ripple), and USB voltage output is also affected by the length/quality of the connecting cable.

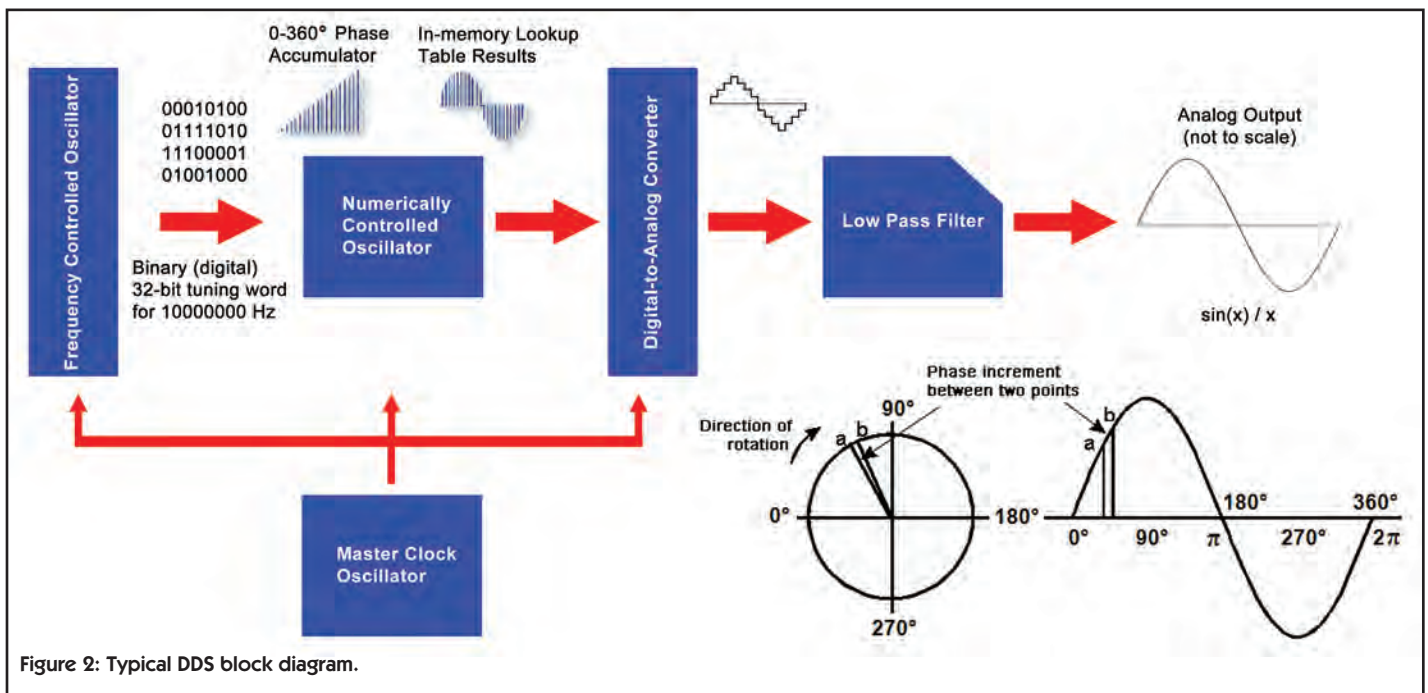

Figure 2: Typical DDS block diagram.

Many DDS modules don't have a temperature-controlled crystal oscillator (TCXO) and the MCO is very sensitive to ambient air temperature changes requiring a housing of some kind to mitigate this problem. Frequency errors are also caused by the "cut" of the MCO's crystal and most don't resonant exactly at the frequency stamped on their cases.

Sine wave RF output voltages aren't constant across the tuning range (see Figure 3) because of the sine cardinal (sinc) function or $\sin(x) / x$ which "plagues" DDS devices without an automatic level control (ALC). For the AD9850, it's just over 1 volt (peak-to-peak) at the very low end and continually drops as you increase in frequency.

This is the reason for our DCR's LO level adjust potentiometer (VR1) because the SA612 Gilbert cell mixer requires a drive RF voltage between 200-300 millivolts (peak-to-peak). The DDS square wave RF output is fairly constant around 6 volts (peak-to-peak) but it's harder to adjust for use with the SA612 (very easy to overload).

Note: There are many variations of AD9850 DDS modules. In general, ones with 125 MHz crystals operate at 5 volts and ones with 110 MHz crystals at 3.3 volts. The higher crystal frequency puts the MCO well above the top of the commercial FM band (108 MHz), reducing images/aliasing but it draws more current. Later version AD9850 (complementary) square wave outputs are no longer capped at 1 MHz.

ARDUINO + DDS + C = VFO!

You can use almost any microcontroller unit (MCU) with the AD9850 but the Arduino has a lot of public ("open-source") support code making it a breeze to use (even for non-programmers). By combining an Arduino MCU, DDS module and some program code, you can create a very handy RF variable frequency oscillator (VFO) gadget to drive external circuits like a receiver or transmitter, test/calibrate devices, troubleshoot circuits and/or generate other wave forms, and so on.

Figures 4 and 5 on the next page are pictorial/schematic diagrams for connecting the Arduino Uno, DDS module and LCD circuit. Because I'm only interested in data modes which are heavily "channelized", a rotary encoder wasn't included (the digital equivalent of an analog rotary switch) and up/down "tuning" is via a single pushbutton ("S1") mounted on the AD9850 module's breadboard shield. However, after finding code written by Ben Buxton and his excellent tutorial, the hardware and software was modified to include one (a KY-040 "brick"), spinning it off into a separate DDS VFO gadget.

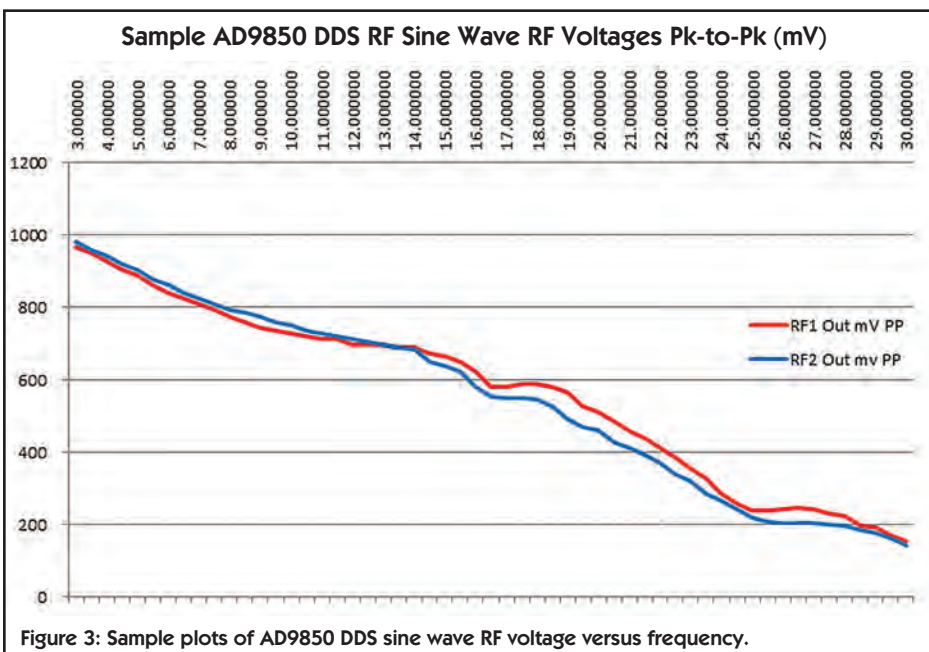

Figure 3: Sample plots of AD9850 DDS sine wave RF voltage versus frequency.

Deadlines for TCA
 September-October 2015: July 15
 November-December 2015: September 15

Please send all submissions by email to the Editor at tcamag@yahoo.ca
 Or by mail to:
 The Editor
 720 Belfast Road, Suite 217
 Ottawa, ON K1G 0Z5

CALIBRATION, CALIBRATION, CALIBRATION

Figure 6 on page 39 is a composite of two graphs; the top one depicts frequency errors for two apparently "identical" AD9850 DDS modules but it's very clear that their individual frequency errors aren't identical and that you just can't add (or subtract) some fixed frequency to correct for this. However, their plots do have a constant slope which we can calculate and graph (bottom), and this value – usually measured in parts-per-million (ppm) – while different for each, is constant across their tuning ranges. Testing individual DDS modules and creating graphs is very time consuming and tedious, but there is another calibration method using audio DSP programs like Spectran (also Argo or Spectrum Lab).

Method 1: Spectran Software DDS Calibration

- 1) Disconnect outside antenna from the reference receiver or transceiver.
- 2) Switch to USB receive mode (no RIT or IF shift, etc.) and tune to exactly 19.999.00 on the dial (1000 Hz lower than the DDS calibration frequency).
- 3) Power up the programmed Arduino (DCR-SDR version) and select memory channel 0 "CALIBRATE" 20 MHz (using pushbutton "S1") or manually tune to 20 MHz (DDS VFO rotary encoder version).
- 4) Couple the DDS RF sine wave output with a length of wire to your radio's antenna input. **Do not use** the square wave output!
- 5) Connect an audio cable from the radio's speaker output to your computer's soundcard line or microphone input.
- 6) Start Spectran and slide the horizontal AF frequency display (grab and slide with mouse) and centre it on 1000 Hz. Adjust the radio volume and soundcard mixer controls so you can see an audio signal peaking somewhere in the Spectran spectrum display near 1000 Hz, with a white vertical line dropping down the waterfall (see Figure 8 on page 40).
- 7) Let everything warm up and reach thermal equilibrium (at least 30 minutes) before making measurements/calculations. Keep the (room) temperature constant; 25 °C is the standard but I don't have access to a thermally controlled housing so I used 20 °C.
- 8) The audio signal's frequency and trace will vary slightly so take a reading every minute and average ten. Your soundcard has a crystal controlled MCO (or two) as does your computer and receiver so their collective/cumulative frequency errors must be taken into account.

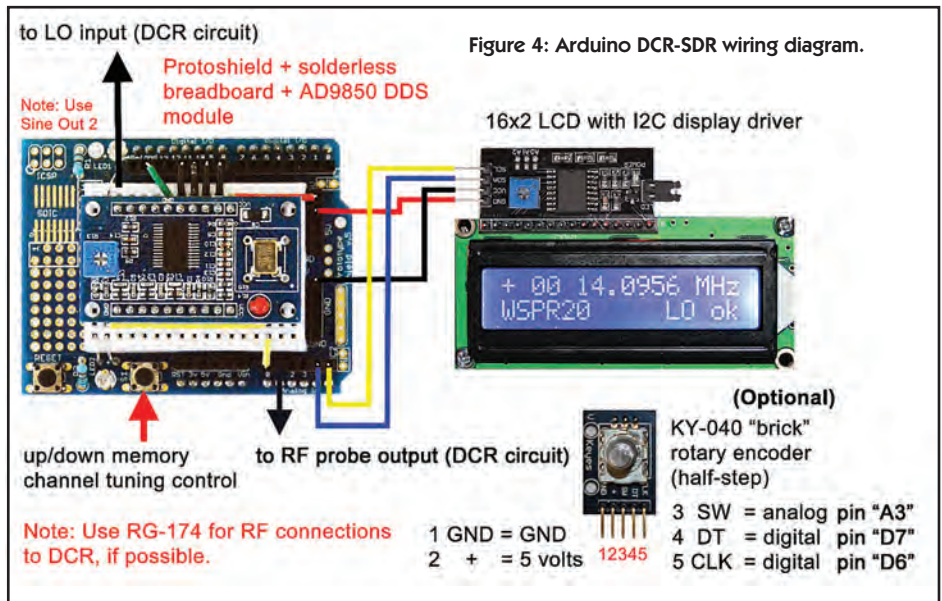
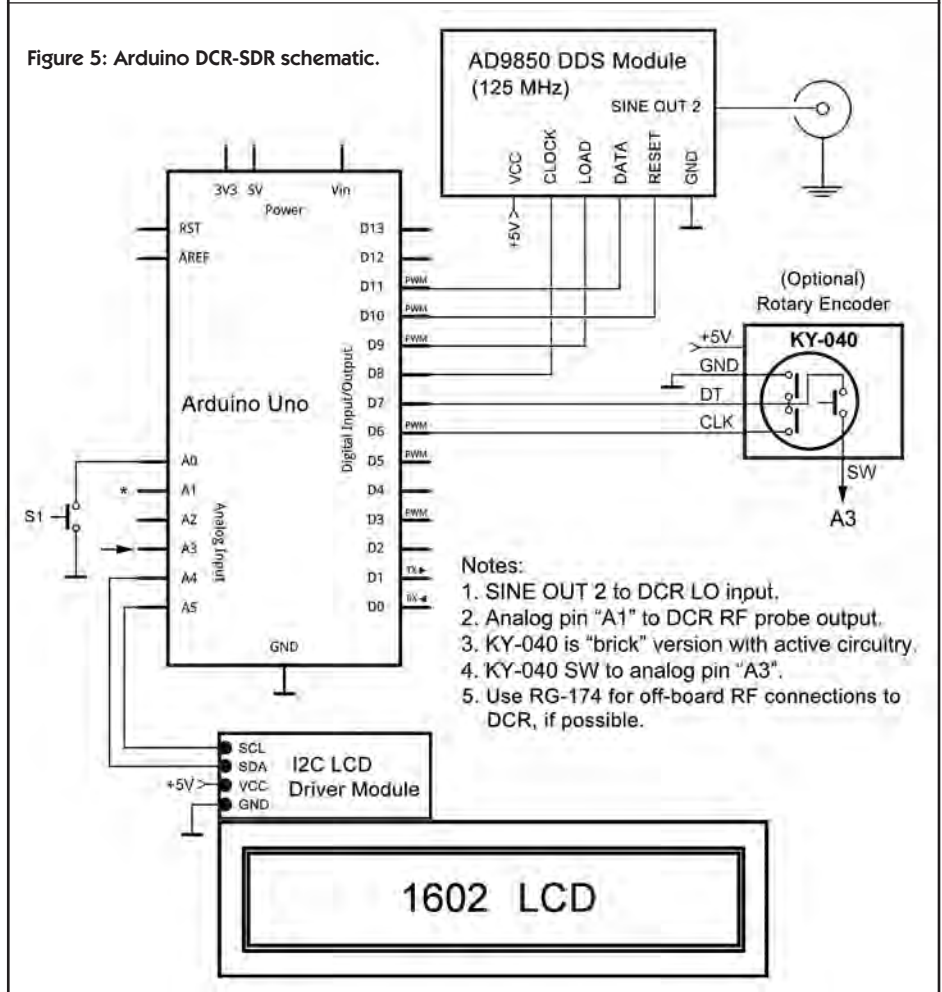

Figure 4: Arduino DCR-SDR wiring diagram.



9) The difference between the two RF frequencies (20 MHz and 19.999 MHz) will produce a 1000 Hz audio beat note if the DDS generated frequency is spot on. Calculate the parts-per-million error by subtracting the average audio frequency from 1000 and dividing the result by 20.

For example, the Spectran audio frequency average is 1040.34 Hz:

$$(1000 - 1040.34) / 20 = -40.34 / 20 = -2.017 \text{ ppm}$$

Note: I've skipped the conversion step to parts-per-million.

This specific module's ppm error correction is negative because it generates DDS frequencies too high, but others can be too low (positive ppm error correction). Assign this to the DDS_CORR value (in both Arduino programs) and we can mathematically "pull" this specific DDS module's MCO crystal by the proper amount for any frequency.

Method 2: Faster DDS Calibration

1) If you want to really simplify and speed up things, use an RF frequency counter (see Figure 9 on page 40). While it's not as educational or demonstrative as Method 1, it's a necessity when you have to calibrate umpteen DDS modules (stick a label on each with their ppm correction).

In this case, just subtract the two RF frequencies DDS (20 MHz) minus frequency counter (xx MHz) to determine their difference (in Hz) then divide by 20 (two conversion steps are skipped to Hz and ppm):

For example: $(20 - 20.000403) / 20 = -40.3 / 20 = -2.015 \text{ ppm}$

While Method 1 is slightly more accurate (unless your counter can measure frequencies to 1/100th of a hertz), Method 2 is much faster and close enough until we house the circuitry and (must) recalibrate anyway for the increased ambient air temperature inside the case (from heat generated by the electronics).

WHAT TO DO WITH DATA MODES DATA?

The DCR_SDR program includes a sample of some popular data mode frequencies you can try using free DSP decoding software such as WSPR, Fldigi, MMSSTV or MultiPSK.

There are many Internet servers to where you can upload your received data and share with the world: WSPRnet, APRS-IS, World SSTV Cams, Reverse Beacon and PSKReporter (see Figure 10) which are accessible 24/7 (to anyone) for research, data analysis, equipment testing, mode comparisons and/or propagation experiments and so on.

Note: TCA is best viewed in colour at: <http://wp.rac.ca>

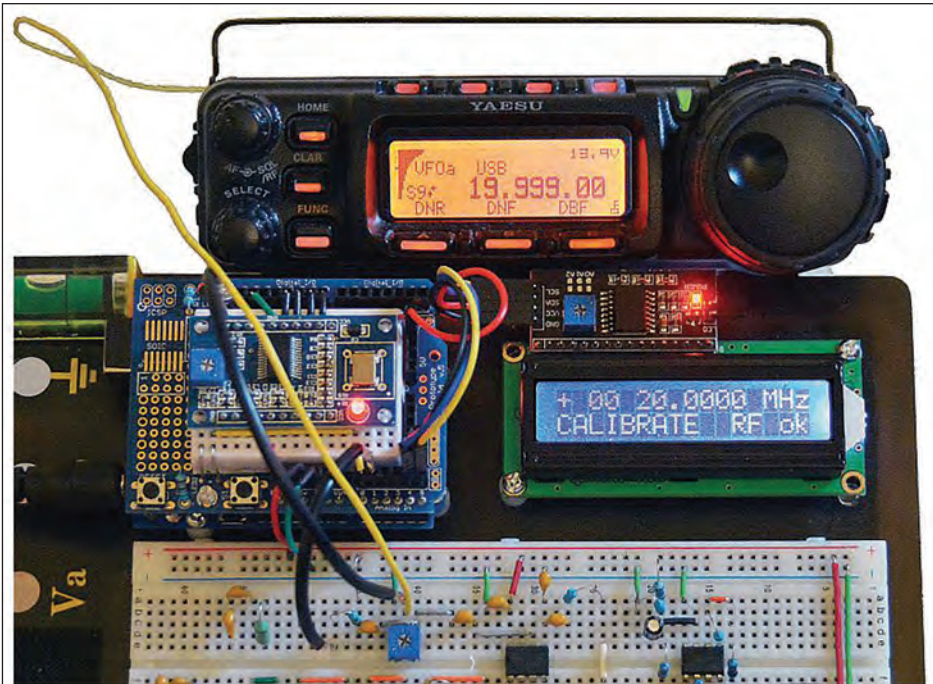
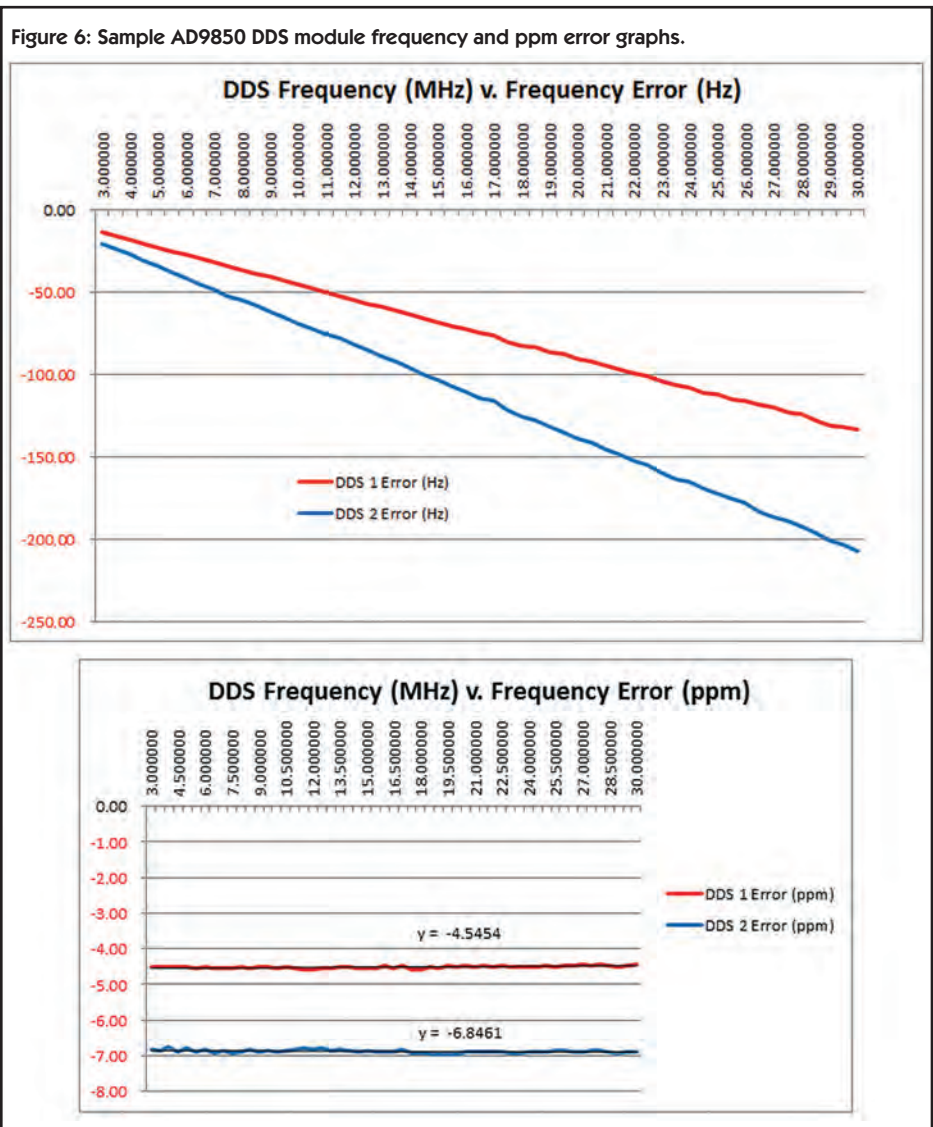

Figure 7: AD9850 DDS module calibration using external radio (Method 1).

MY FINAL

If you want to delve deeper into the MCU/SDR world, check out TEN-TEC's Rebel and Patriot transceivers, built around the chipKIT Uno 32, a 100% hardware/software compatible Arduino Uno on "steroids". There's a huge following of Ham-fans happily modifying/enhancing them and sharing their efforts but, interestingly (to the techies), the Uno 32 isn't an Atmel AVR – it's a Microchip PIC!

My next column looks at an analog data mode called slow-scan television (SSTV). The devastating Nepal earthquakes in April and May of this year destroyed much of the commercial communication infrastructure around the epicentres and Amateur Radio was essential for providing emergency voice / data communications (EmComm). SSTV was used to transmit images from many (isolated) affected areas back to the authorities, assisting them in their decision making. – 73

REFERENCES AND RESOURCES

Audio DSP Software (Windows)

<http://tinyurl.com/nfakd>
<http://www.weaksignals.com>
<http://tinyurl.com/33co2h>

Audio DSP Software (iOS)

<http://tinyurl.com/m3gby5k>

Data Modes Networks

<http://wsprnet.org/drupal>
<http://aprs-is.net>
<http://www.worldsstv.com>
<http://www.reversebeacon.net>
<https://pskreporter.info>

Data Modes Software

<http://tinyurl.com/2wgcp2f>
<http://tinyurl.com/32vguj5>
<http://tinyurl.com/pqzfgcu>
<http://tinyurl.com/6vblqk>
<http://hamsoft.ca>

David Mills, G7UVW

<http://tinyurl.com/ou9yosq>

Nyquist Frequency

http://en.wikipedia.org/wiki/Nyquist_frequency

Paul Darlington, M0XPD

<http://m0xpd.blogspot.ca>

Rapid Tables (ppm)

<http://tinyurl.com/owgoglj>

Rotary Encoders, Done Properly

<http://tinyurl.com/ouhw599>

TEN-TEC MCU Transceivers

<http://www.rkrdesignsllc.com>

Understanding DDS

<http://tinyurl.com/ojkje68>

VA3ROM: All Things Digital

<http://tinyurl.com/og2acxq>

Figure 10: Arduino DCR-SDR 30 metre band JT65-HF reception reports uploaded to PSKReporter over a 24 hour period.

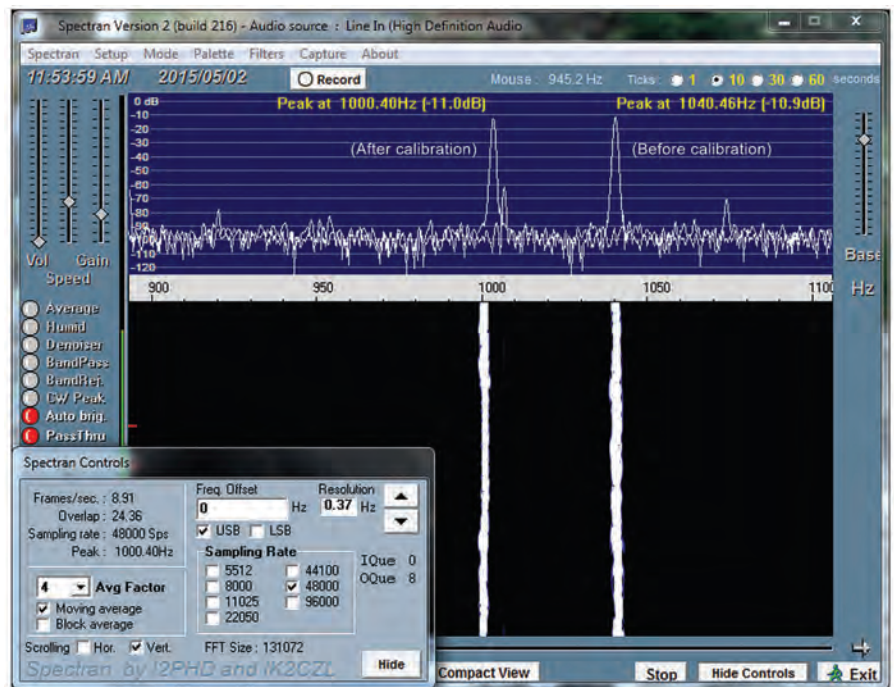

Figure 8: Composite Spectral images of AD9850 DDS module calibration method 1 (before and after).

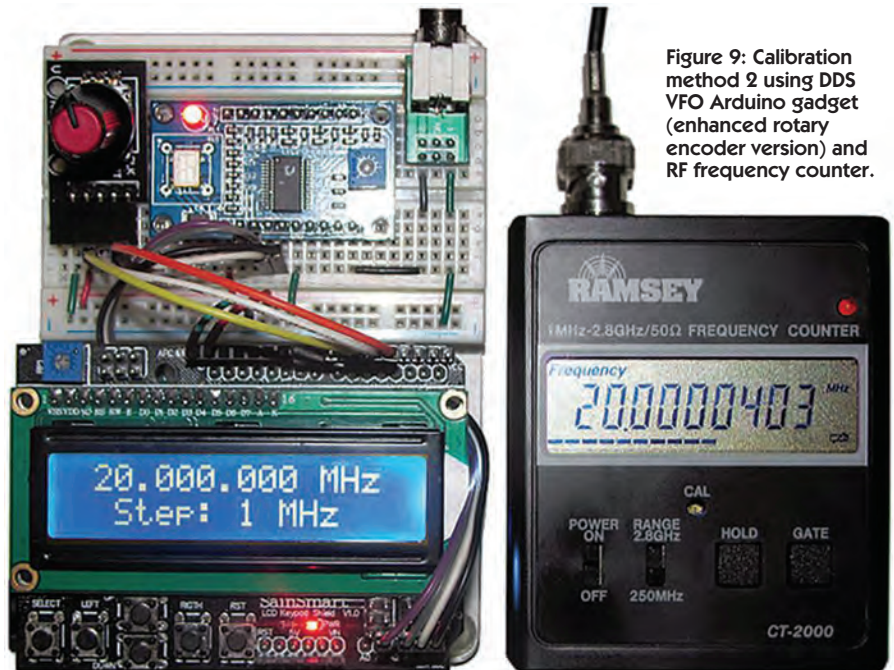
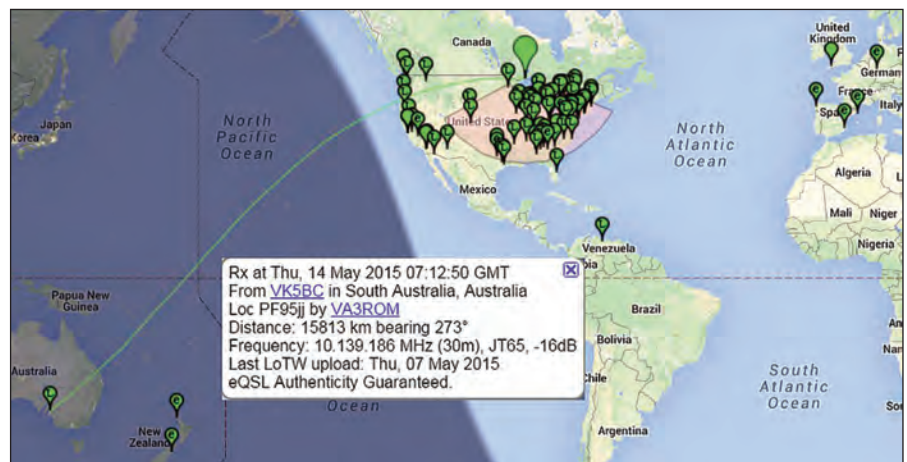

Figure 9: Calibration method 2 using DDS VFO Arduino gadget (enhanced rotary encoder version) and RF frequency counter.



RANDOM THOUGHTS...



Dirk Moraal, VY1NM
Box 75
Tagish, YT YO8 1T0

Contest, what Contest?

Taking advantage of Global (Induced Ionosphere) Warming

Living in the north,

where we have plenty of other things to occupy our time – mostly subordinate to what the WX is doing, or will be doing shortly – I have never been too bothered by the contest bug. And so because I neglect to look for upcoming events, I am never sure when or what the jousts are about nor what the exchange or the protocols might be.

Mostly I just stumble over the pileups, listen for a chance at a choice piece of DX, wedge myself in, steal the cheese, and be on my way. Life is short, after all and the woodpile calls.

But now and then something happens to me and even though I tell myself I will only make one little call, just to say I did, the madness takes over. Those contests can be like eating peanuts or maybe pickled eggs and beer; once you start you just can't stop.

As it happened, I had not been on the air for a number of days, mostly from an itchy case of poor propagation, and as I started checking the bands I heard a YL calling CQ.

I perked my ears and using my best voice, called her back, but she, oh so sweetly though, told me she was looking for real DX. OOPS! My bad. Hasty apologies followed and I went rushing to the latest issue of TCA, where I found out that I had stumbled onto the ARRL International DX SSB Contest. No kidding, I said to myself. I wonder who would be on that. Just about everybody, it turns out.

At that time of day 40 metres was dead and 20 metres was faint, so flexing my dial finger I scooted up to 15 and it was wall to wall loaded with juicy DX! Typically, I told myself I would be a nice guy and hand out a few multipliers if I could get in. Not many mind you – I had to remind myself – just one or two to say I did, and then be on my way. But I reckoned not with the DX capabilities of that little NVIS antenna hovering nearby in the breathless -36°C morning air.

It started innocently enough, but when I tried stealth techniques to bust into the pileups, I started to have trouble keeping the paper log up to date. JAs were everywhere. This gave me an idea (you know how it is – you say to yourself “Hey! I have an idea!” and it snowballs from there.) I would try to log at least one call to each of the 10 JA zones, 0 to 9 not necessarily in that order, just to make it easier. I have done this before but not all in less than 24 hours! It would be my own private little game. I was not really contesting, I told myself. I knew this to be true as I have had to repeatedly convince myself of this on several occasions during other contests. It was not an easy thing to accomplish as I logged irresistible QRM from YB1, CE3, HK1, PX5, RW0, RT, LP1, VP5, PJ2, P4, FY5, 9M6, C6, CR2, TI8, and ever a cornucopia of JA stations like I had never heard before. And I wasn't even trying.

Back in the operating seat there was a prevalence of zones 1, 2 and 3, quite naturally as that is where most of them live, and it was very noticeable that they were politely spaced at 3 kHz up and down the 15 metre band and the same on 10, intermingled with QRM from the neighbours in between.

I soon came across 4, 5 and 7, then a harder to get 0, and later in the campaign I pounced on an unsuspecting 8. I went back over to 20 metres and boy oh boy, the cacophony of sound that assaulted my senses; most everybody else was there too. Not a kHz was free in between.

Note to self: get some of those filters for the little radio.

I was glad I was not contesting. It was like listening to one continuous pileup. But I winkled out a JH6, and Wow, I was so close to my goal. The elusive last zone was giving me the fits. But to fill in the time, I had a couple of very pleasant distractions, helping out a half-dozen DX stations running Multi ops, and it was surprising how much work they put in to getting a multiplier or three from a modest VY1 station. Some day someone must explain it to me. Their efforts deserved a bit of cooperation and I made sure they got it.

For me, it was another head shaker. How come I was having such a busy time with DX if I only had a modest station, 60 watts, and a dipole antenna only a few metres above a strip of chicken wire? I even had a DX QSO with Aruba on 40 metres and I don't even have a real antenna for that.

Something marvellous was happening. Was it true that increased RF activity on the bands excites ions and strengthens the F layers? And certainly we must be at or near a peak in this Solar Cycle. That helps. And the contest stations indirectly benefit humbler stations like mine with their better hearing and transmitting capabilities. (Thanks!) And I must take another look at that Propagation handbook. And maybe I am just a lucky guy. I glance over at my tea cup and note that it is half full, not just half empty. Maybe that has something to do with it, as well.

And for those readers who have been counting, yes, Oh Joy!, I did finally manage to get the last zone I needed, a JR9 to complete the series, at 2353Z – just seven minutes before the contest closed! Now that, I maintain, was well worth the whole 24 hours.

So that is how I spent most of a weekend not contesting while the whole rest of the world around me did. And on Monday, yes I checked, the bands were as lonely as the distant, wide, still forested places.

My thanks to all the contesters for helping make it happen.



APRS and SMS Converge

Paul Dufresne, VE3OTB

Shortly after obtaining my Amateur Radio licence, I became very interested in the Automatic Packet Reporting System (APRS) and its applications for emergency communications. I quickly discovered that I could send and receive APRS messages from areas that were well out of cellular range and I had the idea that it would be very useful if the APRS network could exchange messages with the cellular Short Message Service (SMS).

I began the development of APRS/SMS Gateway in the spring of 2013. I consulted with Bob Bruninga, WB4APR, the inventor of APRS, along with others in the APRS community. The idea was simple, create a piece of software that could communicate with the APRS network via the Internet, leveraging the APRS-IS network that links APRS iGates around the world and connect it to the cellular network.

The first step was working out how to communicate with the APRS-IS network. Connecting to an APRS-IS server is simple enough, but you need login credentials and you need to establish a filter to avoid being bombarded with every APRS message being sent around the world. The software basically filters APRS messages for only those with a destination matching its APRS alias, SMSGTE, and uses the same APRS-IS connection to send messages to the APRS network.

On the cellular side, I initially used a USB cellular Internet stick as an SMS modem. This worked well as a proof of concept, but tied up my USB stick and was a costly way of operating. I later replaced it with a subscription from Clickatell, an SMS gateway provider.

In the spring of 2014, SMSGTE went live on APRS, offering users the ability to send and receive messages between APRS and cellular SMS. It has been in regular operation ever since.

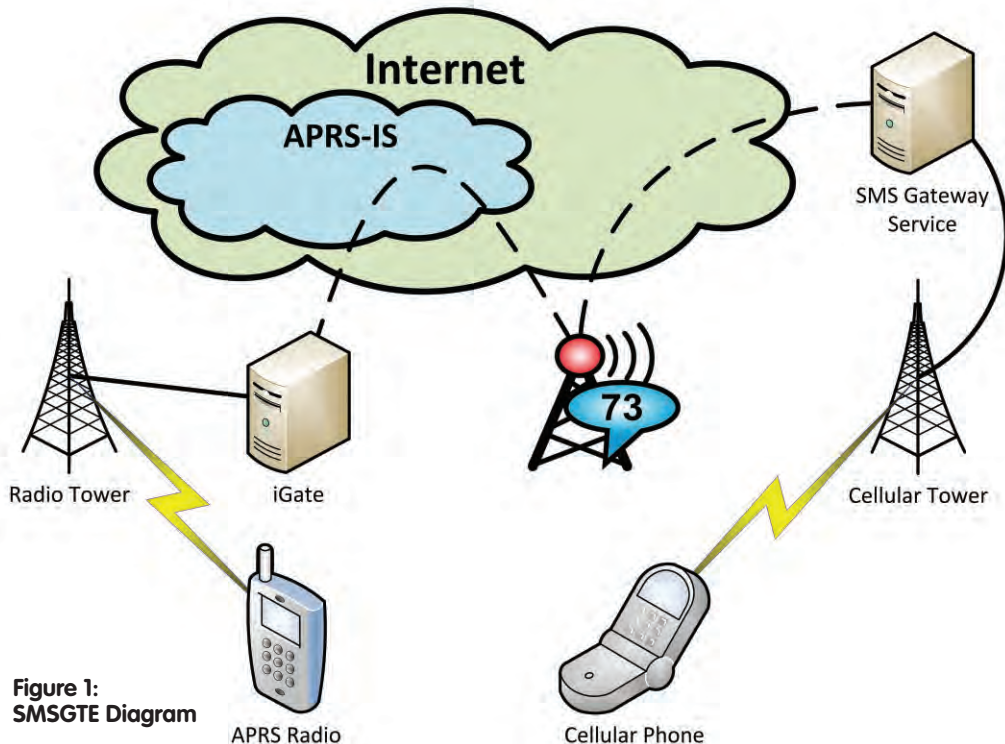

Figure 1: SMSGTE Diagram

So how does it work? When sending a message from APRS, simply address your message to SMSGTE (see Figure 1). In the body of your message, you initiate a conversation by specifying the destination number preceded with an @ symbol.

For example:

To: SMSGTE

Message: @6135551212 This is my message.

Assuming you're sending from a radio (such as the Kenwood TM-D710 as shown in Figure 2), the message will be picked up by an iGate and sent across the APRS-IS network.

The SMSGTE software receives the message and parses it. Since the first word in the message begins with an @ symbol, the gateway uses that word as the destination and sends the rest of the text to the SMS user. The first message initiates a conversation, such that subsequent messages don't need to be specifically addressed. The gateway will assume that the next message (unless you specify otherwise) is intended for the same recipient as the last. If the SMS user replies, the response is automatically routed to the originating APRS user.

Similarly, users can send messages from an SMS device to an APRS user. (see Figure 3 on the next page) Messages sent to the SMSGTE SMS number, which is not published (the only way to learn the number is to have received a message from the gateway) are received, parsed and passed along to the APRS user.

For example:

To: 2125551212 (SMSGTE number)

Message: @VE3OTB-9 This is the message.



Figure 2: Sample message on Kenwood TM-D710

**Figure 3:
SMS
Screenshot**

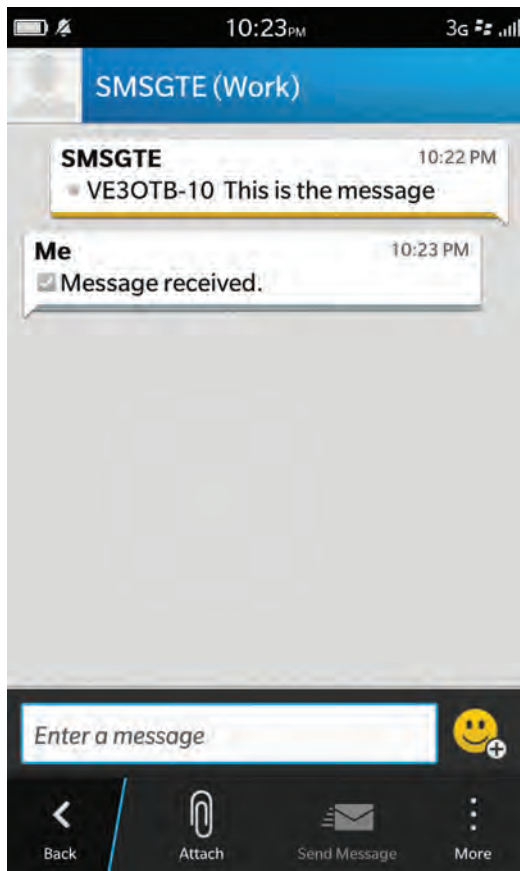

The message is received by the SMS service provider and, using a web-based API, delivered to SMSGTE.

SMSGTE will treat the first word as the call sign of the intended receiver, format the message and send it through the APRS-IS network.

Assuming the destination is a radio, an iGate that has recently heard the call sign on-air will receive the APRS message and repeat it on-air for the radio to receive.

As before, the gateway will assume that any replies are destined for the last SMS user to send a message to the call sign.

I am often asked if there are barriers to ensure that unlicensed third parties are unable to originate traffic into the Amateur Service through this gateway.

In the case of a message from SMS to APRS, the message only enters the Amateur Service when the iGate transmits it for local delivery to the destination station. In addition, APRS is a data transmission, which means it is permissible for the station (in this case the iGate) to be automatically controlled.

There are also barriers inherent in the way the system operates. First, the SMS number assigned to the gateway is unpublished. Only someone who has received an SMS message from the gateway would have the number. Having the number isn't enough, however as you must know the message format and a valid call sign to send the message. The gateway also only responds to messages addressed to a known destination call sign, specifically call signs that have previously used the gateway. In addition, the message will only be gated to RF by an iGate which has recently heard the destination station.

Here are some examples:

- A message sent without a valid call sign as the first word will be ignored (no response sent to the SMS user)
- A message sent with a valid call sign that is unknown to the gateway will be ignored (you have to have used the gateway to receive from it)
- A message sent to BLN or a group call sign will be ignored

- A message sent to a valid call sign that is inactive (not recently heard by an iGate) will be sent to APRS-IS, but never sent to RF

The exception is when a conversation is active. If an APRS user has sent a message to an SMS device, replies from that device will be automatically addressed to the APRS user, the call sign does not need to be included.

Conversations are kept for 24 hours after the last message was sent.

APRS users also have the option of enabling privacy mode. When privacy is enabled, the user will only receive messages from SMS numbers for which they have configured aliases. This allows the APRS user to control inbound messages destined to them. With privacy enabled, all messages for that user from SMS will be ignored by the gateway unless they meet one of the following conditions:

- The source number has been configured with an alias by the APRS user
- The source number is associated with another APRS user (that user's alias will appear as an alias in the message)
- The message is a reply in an active conversation initiated by the APRS user

In addition to the simple examples provided above, users are able to create aliases for frequently used numbers, configure shortcuts for frequently used words or phrases, request delivery confirmation and even send a map of their current location (from APRS only).

After over two years of development, the gateway is now in regular operation, providing a communications bridge between APRS and SMS. The gateway serves hundreds of users across Canada and the United States and handles a few hundred messages each month.

If you would like to learn more about SMSGTE, please visit my website at: <http://smsgte.wix.com/smsgte>

Paul Dufresne is a relative newcomer to Amateur Radio, having obtained his Basic with Honours and Advanced certificates in January of 2013. His background is in telecommunications, mainly networking and telephony with an interest in programming and electronic technology in general. Paul's interest in Amateur Radio was fueled by a need for long-range communications while off-roading in his Jeep.

Figure 4: SMSGTE icon v2



Stocked in **Canada**, Serviced in **Canada**

<http://www.wouxun.ca>

Fleetwood Digital Products | Web: <http://www.fleetwooddp.com>
Email: radio@fleetwooddp.com | Phone: (604) 800-4042

9N1 Emergency: The Response to the Nepalese Earthquakes

Phil A. McBride, VA3QR/VA3KPJ

On April 25, 2015, at 6:11 am UTC, a devastating 7.8 magnitude earthquake struck Nepal, causing widespread destruction and loss of life. Very shortly thereafter, Satish Kharel, 9N1AA and Amir Bazak, 4X6TT, established communications on 14.210 MHz and began to prepare to pass traffic.

I became aware of the net's existence late that Saturday evening from a DX spot that appeared on my logger, call sign 9N1EMERGENCY. When I tuned over, there was chatter on the net between 4X6TT and Colin Wilson, CT7ACG and they were looking for relay stations.

I checked into the net and volunteered to listen and relay traffic while conditions gave me a path into Europe. I would go on to act as a relay – and a few times as Net Control – every night for the next six nights, usually starting around 11:30 pm UTC and ending around 2:30 to 3 am UTC. When I wasn't in the shack monitoring the net, I allowed CT7ACG remote access to my station.

The net originally convened on 14.210 MHz and, two nights later, the net was split between two frequencies: 14.205 MHz for priority traffic; and 14.215 MHz for secondary traffic such as technical discussion, volunteer offerings and assignments. This was an unusual frequency assignment and we all knew it. It's right in the middle of the "contest" portion of the band and right above the DXpedition window. What few understood was that 9N1AA was experiencing severe interference about 20 kHz on either side of the IARU Emergency Centre of Activity (ECoA) frequency of 14.300 MHz. On Friday, May 1 at approximately 4 am UTC, the net was moved to 14.300 MHz after 9N1AA confirmed that the previous interference was gone and the various maritime nets that run on that frequency stood down.

At approximately 4 am UTC on Saturday, May 2, 9N1AA informed us that primary telecommunications channels had been restored to the point that emergency, priority, health and welfare traffic could flow to the Nepalese government and associated relief agencies, and that he and his equipment were being deployed to the epicentre of the earthquake.

It was decided that our operations on 20 metres would close so that the Amateur Radio resources in and near Nepal could be better used within the country for regional communications.

Many, many people saw the DX spot and came on frequency and offered to help us monitor, allowed us to utilize vital contacts, donated equipment and provided anything we needed.

At the time of the submission of this article, radio equipment donated from all over the world is still awaiting entry into Nepal, mainly consisting of VHF/UHF handhelds, a repeater, and 40m mobile-mountable verticals and transceivers, which will be used to establish regional communications while other infrastructure is being rebuilt and restored. Our operating frequencies were being monitored by the UK Foreign Office and the US Department of State during the initial response to the crisis.

On the other side of the coin, the amount of intentional interference we had to contend with was like nothing I've ever experienced. While we were on the lower portion of the band – and even when we moved to 14.300 MHz – we had people yelling at us for taking up bandwidth, people constantly tuning on the passband, recorded music and all out profanity. Several of us made very high quality recordings and took down directional information, and all of that information has since been submitted to the International Amateur Radio Union for investigation. In addition, there are unconfirmed reports that some of those responsible for the interference from Europe and Australia have been found and charged by their licensing authorities.

The net never passed any traffic that would be defined as "emergency" traffic, but we did pass relief traffic and were able to establish the whereabouts and welfare of several people who were reported missing. What is also of note is that this was not an organized effort. There was no deployment, no call-up tree, few of those who operated had emergency communication or traffic handling training and/or experience, and there was no top-down infrastructure in place. It just happened; spontaneously, very quickly, and it grew at an amazing pace.

At no time was the net under the control of any "established" group; just a bunch of Radio Amateurs trying to help out as best they could.

On May 13, there was another earthquake in Nepal, this time a 7.4 magnitude event centred in the eastern part of the country. While traditional lines of communication into Nepal remain intact for the most part, 9N1AA is still making scheduled contact with the group about twice a day to maintain a communications backup and to pass relief and health/welfare traffic.

The "core" group that have been involved in these efforts from the beginning have formed a committee to explore the creation of an established group (<http://www.iarern.org>), with the primary goal of training HF operators in the emergency communications procedures laid out in the IARU Emergency Telecommunications Guide. We don't want to become a group that's called up when there's a need (although that would be possible); rather we want to create a large base of operators well-versed in already existing international communications standards in the event that something like this happens again.

The following, in no particular order, are considered to be the "regular" group who maintained the network:

4X6TT, 9N1AA, CT7ACG, VA3QR, DK3LQ, OH8XAT, N0UN, ZL2TZE, SV1HX, GW1FKY, G3PHO, VO1COD, CT4AN, 4X1RU, WA4YBC, M6KVJ, G3TUY, DC8BJ, GJ7DNI, LA3XIA, ON4CL, G0UIQ, GW4BRC, KD4QFT, EI9JU, VU3SIO, AD5XT, KA0HDJ, VE6TFC, AG4I, WB7S, VY2HR, KC7RUN, DJ7WW, SB7W and ND7J.

I believe this operation once again proved the usefulness of Amateur Radio in a crisis, and exemplified the spirit of the vast majority of those who call themselves Amateurs. I would like to thank all those who took part in this operation and offered their time and support in this worthy endeavour.

Phil was licensed in May of 1994 and holds his Advanced certificate. He has served as RAC ARES Emergency Coordinator, Assistant Section Manager and is a member of the Canadian Forces Affiliate Radio System (CFARS). His personal website is <http://www.va3qr.ca>.

RAC OFFERS BOTH BASIC QUALIFICATION STUDY GUIDES



The Hamstudy Basic 2010/2011 Study Guide...

This is the perfect reference for new Radio Amateur enthusiasts. It provides everything needed to qualify for the Basic Exam. The focus is on topics that are addressed in the examination, from Ohm's Law to Yagi antennas, courteous operating, and much much more.

- ✓ Industry Canada's complete examination question bank
- ✓ Based on the popular Internet self-study course HamStudy
- ✓ Low price of \$45.95 (plus shipping and taxes)

Key information:

- ✓ Basic qualification is required to obtain your call sign
- ✓ Exams are multiple choice – 70% to pass
- ✓ 80% or higher marks gives you access to the HF bands
- ✓ Morse Code is no longer mandatory to obtain your licence

The Canadian Amateur Radio Basic Qualification Study Guide – New 9th Edition

Revised and Updated in 2014

RAC is pleased to offer the latest in the series of study guides.

The 9th edition has been completely revised to address changes in technology in the five years since the 8th edition was produced.

- ✓ Matched to the Industry Canada Question Bank update in 2014 with more context for the new and revised questions
- ✓ Still includes unlimited access to the acclaimed online Student Success Pages support
- ✓ New Ask The Professor help added for some questions
- ✓ Same Low Price! Just \$44.95 plus shipping and taxes

Note: The Canadian Amateur Radio Advanced Qualification Study Guide is also available. Please see the ad on page 35 for more information.

Visit the RAC Online Store for these and other great items: http://www.cafepress.ca/rac_radio

HAMSTUDY BASIC

2010/2011

EVERYTHING YOU NEED TO KNOW FOR YOUR CANADIAN BASIC EXAM

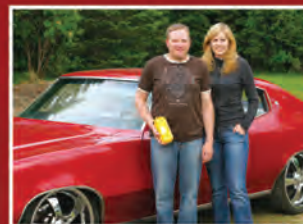

RADIO AMATEURS OF CANADA
www.rac.ca

Canadian Amateur Radio Basic Qualification Study Guide



Ninth Edition

Includes Unlimited Access To Student Success Pages On Our Web Site!

Coax Publications Inc

PUBLIC SERVICE / ARES

ARES: AMATEUR RADIO EMERGENCY SERVICE

GUIDES ON THE AIR IN BRITISH COLUMBIA

Submitted by Marcy Lui, VE7JT

The Coquitlam Amateur Radio Club (CARC) supports Guides on the Air (GOTA) and, as a former Brownie, it has always been a pleasure for me to volunteer as an HF operator at the event in February each year. We would host one or two Girl Guide units per year to tour our communications facilities, learn about Amateur Radio and the Amateur Radio Emergency Service, and get the girls on the air.

The most memorable HF contacts were with VA1YL GOTA station and with the USS *Pampanito*, a World War II Balao class Fleet submarine which is now a memorial and museum ship in San Francisco Maritime National Park Association located at Fisherman's Wharf in California. The girls were so excited to speak to their counterparts in Nova Scotia and to speak to a submarine station.

Last year, the Coquitlam Amateur Radio Emergency Services Society (CARESS) held GOTA 2014 in the Heritage Museum at Leigh Square in Port Coquitlam. This was a much larger event with 72 Sparks, Brownies, Guides and Pathfinder attending.

The event was such a success that it was decided that this year's event, GOTA 2015, would be hosted by Surrey Emergency Program Amateur Radio (SEPAR) for Surrey area Girl Guides. I am member of both CARESS and SEPAR and took a lead role in coordinating the events, but unfortunately I was unable to attend on February 21.

The goal for SEPAR's GOTA was to ensure all Girl Guides (Sparks, Brownies, Guides and Pathfinders) earned the

CARESS event:
Nicole, Jaida, Jaelyn,
Julie and Serenity
operating Morse code

GOTA badge by connecting Girl Guides with another Girl Guide station. In addition, Girl Guides can also earn the Thinking Day on the Air (TDOTA) badge by connecting with a non Girl Guide station. To realize this goal the plan was to schedule HF contacts with other GOTA stations. HF scheduled contacts are dependent on conditions and are not always successful. With that in mind the thought was to schedule VHF GOTA contacts concurrent with HF. A quick email to CARC to see if CARESS would be hosting GOTA 2015 was met with a positive response and a VHF GOTA contact was secured.

A working relationship was quickly established with Marlene, the Program Adviser for the Fraser Skies Area Girl Guides via Girl Guides of Canada / Girl Guides of Canada BC Council. Marlene was very enthusiastic about GOTA and her wish was to see Surrey and the rest of her area (Delta, Langley, Abbotsford, Chilliwack and Hope) and also Greater Vancouver involved.

Letters of invitation were sent out to local Amateur Radio emergency organizations, whose members are cleared by the RCMP to work with youth. The Abbotsford Amateur Radio Emergency Services Society (AARESS) and the North Shore Emergency Team (NSET) joined SEPAR and CARESS. AARESS was subsequently stood down prior to the event date.



SEPAR's commitment in support of GOTA was to share its expertise, Amateur Radio related worksheets and interactive activities – which were developed for their Amateur Radio Community Workshops for Youth – with CARESS, AARESS and NSET (later changed to North Shore Amateur Radio Club). Planning support was also extended to Williams Lake GOTA on request from the Girl Guides of Canada BC Council. We were happy to be of assistance.

One frequency plan was developed for group use: HF and VHF (repeater, IRLP, Echolink and simplex). One schedule plan was organized incorporating outside area contacts between our organizations.

The TDOTA United Kingdom's station list (<http://www.guides-on-the-air.co.uk/station-list.html>) was a great resource for outside area contacts.

SEPAR worked in partnership with Guildford Recreation to provide Port Kells Hall as the event location.

The following reports describe the Guides on the Air events in each area.

NSARC:

The North Shore ARC hosted a Guides on the Air station on Saturday afternoon from 1 to 5 pm. Under the leadership of Gordon Passmore, VA7GAP, the Club hosted a total of 68 Brownies and Guides as well as two younger brothers (Beavers) who snuck in when we were not watching!

Radio traffic was HF and VHF, simplex and repeater. Most of the girls made at least one contact and some made several. Other activities were Morse code and the phonetic alphabet which the girls practised on the air. The average QSO lasted several minutes and much personal information was exchanged.

The day was very successful, thanks to the following club members:

Keith Witney VE7KW, David Shipman, VA7AM and Leif Erickson, VA7CAE, were in the Radio Room; Tom Dunn, VE7TD, demonstrated Morse code; Donna Erickson, VA7DME, coached the girls with phonetics; Bob Paxton, VE7RPX and Igor Kusec, VE7AXO, coached the girls on the air; and Sally Finora, VA7SMF, helped with registration. John White, VA7JW, who did yeoman service on 80 metres, made contact with

the Radio Room. Keith Witney, VE7EXH, Bob Allison, VE7BWC and George Merchant, VE7QH, among others, made contact with the Club station on the Club repeater. Other QSOs were made with stations over a wide area.

The event was organized by Gordon on behalf of the Club, but it's success was due to all the Club members who gave up a sunny afternoon for a very worthwhile cause and the North Shore Guide leaders who were wonderful.

CARESS:

On Saturday, February 21, we hosted Girl Guides from the 1st & 13th Eagle Mountain, 8th Chimo and 1st & 3rd Hyde Creek units – all from the local area – for the annual GOTA or Guides on the Air event. Forty-nine Girl Guides visited our club facilities where we operated two stations: HF (15m, 20m, 40m) and VHF (local repeaters, simplex and IRLP).

The girls were very interested in Amateur Radio and eager to talk to other Girl Guides located across Canada and the US. They were very excited when we made a contact in Venezuela on 15 metres. A little "mike fright" at first soon turned very quickly into enthusiastic question and answer exchanges.

Along with the radio stations, the girls were taught about Morse code using simple exercises and they also learned about the phonetic alphabet.

After the event, the girls visited the SPARC Museum next door, where they were in awe of the incredible antique radios. Nothing but smiles, learning and fun by all.

The event was a success thanks to the following volunteers: Marcy Lui, VE7JT (Event Planner/Coordinator); Paul Wagner, VE7TL (HF Station Operator); Gord Barker, VE7GVB (VHF/IRLP Station Operator); Richard Wodzianek, VA7RLW (Event Manager); and Dan Marsland, VA7DCR (Photographer).

SEPAR:

SEPAR Coordinator Fred Orsetti, VE7IO:

SEPAR hosted a Guides on the Air station on Saturday, February 22 from 10 am to 3 pm. This event required hours and hours of organization between Amateur Radio and Guide leaders.

Schedules were set up and frequencies on HF, VHF and IRLP were identified in preparation for a full day with the Girl Guides.



SEPAR event: 3rd Clover Ridge Guides operating Morse code

The following SEPAR members participated in the event: Stan, VA7NF, Al, VE7CDC, Peter, VE7PGX, Dixie, VA7DIX, Ion, VA7ION, Jay, VE7KC, Jinty, VA7JMR, Rob, VE7CZV, Garvin, VA7YEE and Fred, VE7IO. In addition, Brian Gay, also a SEPAR member, handled the photography and other activities.

All Girl Guides were checked in starting at 10 am by the Guide leaders and then were given an introduction on Amateur Radio and what the schedule of events would be. After the brief introduction the Girl Guides were split into two groups: one group operated the radios talking to other Girl Guides; the second group was again divided into two groups. These two groups, using handheld radios took part in a role play, with one group being on the International Space Station and the other being on Earth. They were provided with questions and answers and used Amateur Radio to talk to each other. Once the role play was completed the two groups joined together for an introduction to Morse code. Rob, VE7CZV, handled the Morse code lesson and within a few minutes the girls were sending their name using a practice Morse code key.

Next the two original groups changed places and the group that just completed the role play and Morse code went to the radios to talk with other Girl Guides. The girls who had been in contact with other Girl Guides then went to the role play area.

Peter, VE7PGX, looked after the Girl Guides who were on the air. He gave them a brief outline of the role of Amateur Radio in emergencies, how SEPAR

served the City of Surrey and what the girls would be doing when talking on the radios. Contact with the Coquitlam site and the North Shore site provided the girls with an opportunity to exchange information about their respective activities. Talking with other Girl Guides using Amateur Radio was exciting for the girls and provided them with an opportunity to acquire their badge. The Girl Guides at the SEPAR station were able to contact VE7MEP GOTA in Victoria, BC and also VA7JML GOTA in Williams Lake, BC on HF and they exchanged information.

Thanks to Gordon Passmore, VA7GAP, of the North Shore ARC/NSET and Richard, Wodzianek, VA7RLW, of the Coquitlam ARC/CARESS and their teams for providing our Girl Guides with an opportunity to communicate using Amateur Radio. Thanks to Jean-Michel, VA7JML, in Williams Lake and to Matt, VE7MEP, in Victoria for their participation in the GOTA event. With so many able stations on the air, the participating Girl Guides had a very positive experience and most certainly are looking forward to next year.

By all accounts GOTA was a great success! Was the event a complete success? During debrief we found two HF scheduled contacts were not successful due to portable set up, conditions and frequency allocation. The remaining HF scheduled contacts were successful. We're looking forward to a completely successful GOTA 2016.

Please join us! – Marcy, VE7JT

Note: For more information on GOTA visit: <http://www.clarayl.ca/index.php/whatisgota>

KITCHENER-WATERLOO ARC: EMERGENCY SERVICES

Submitted by Larry Gorman, VE3LGN
Certified Amateur Radio Emergency
Coordinator for the Kitchener-Waterloo
Amateur Radio Club

The following presentation was made to the Region of Waterloo Community Social Services Emergency Planning Advisory Committee (SSEPAC), explaining our role as an active member of this group, which serves a community of over 570,000 citizens.

EARLY DAYS OF AMATEUR RADIO AND THE MYSTERIOUS CODES

The first radios of any kind were built by enthusiasts who designed and or built their own radios from scratch. They soldered wires to make circuits and plugged in a myriad of tubes. The earliest radios could not send voice, only long or short tone bursts, i.e., code.

Morse Code: Over the years there have been many variations of Dits and Dahs, or codes.

Samuel Morse and his little known colleague Alfred Vail devised the most acceptable dots and dashes system of telegraph transmission. This became known as Morse Code. Commonly referred to as "American Morse" by 1844, this system was, in turn, slightly altered, and is now known as "International Morse."

"CQD CQD SOS" (Urgent-Disaster): Probably the most famous emergency message ever sent was made during the sinking of the *Titanic*, on April 15, 1912; the call for help by the two wireless operators of the *Titanic*. They were ordered by the captain to abandon ship, before the ship went down.

The Demise of Code:

Improvements in electronic engineering have advanced so greatly that the US Navy, the "Keeper of the Code", finally abandoned its use in 1995. However it was kept as a requirement for the Amateur Radio licence upgrade in Canada until 1999. There are still diehards who regularly "ragchew" using high speed code.

WHO DOES THIS STUFF? WHY?

Historically, it was the realm of radio and electronics engineers and experimental hobbyists. Most of the conversations had to do with "RST" reporting. Readability, Signal Strength (loudness) and Tone (as related to clarity of the code).

The ultimate was 5 X 9 X 9: perfectly Readable, extremely Strong signal, perfect Tone.

Experimental development, tinkering if you will, was, and still is, a major reason for the generous no-cost allotment of the now very lucrative RF airwaves. Emergency communications use is another.

From time to time, bandwidth is auctioned off by the federal government for cellphone companies etc. This occasionally causes concern for the Amateur community as attempts are made to encroach on our preassigned bandwidth.

Experimental radio technology has led to the creation of a variety of unique applications. They in turn have resulted in a number of communication spinoffs, such as cellphones, computer enhancements such as VOIP (Voice over Internet Protocol), Skype and APRS, to name a few.

Automatic Positioning (Packet) Reporting System (APRS) can be used to transmit real-time information such as messages, bulletins, announcements and Google-styled maps for locations of any stations or objects. This is a technology with interesting possibilities in a variety of emergency situations.

Most modern radio frequency inventions and applications can be traced back to licensed Amateurs.

A number of local current and former RIM/Blackberry employees are licensed Amateurs.

AMATEUR RADIO IN THE 21ST CENTURY

All these new inventions have led to a reevaluation of what Amateur Radio has to offer. Most current members are now drawn from the general public. You no longer have to be an electronics wizard to operate Amateur radios.

The hobby is in the ongoing process of refocusing, as a provider of emergency communications, to a variety of social agencies. Our purpose is first and foremost to relay official, prepared messages

With so many alternative communications systems available, most Amateurs are now more interested in the application of the hobby rather than the process.

With this in mind, the Kitchener-Waterloo Amateur Radio Club, at a very early stage, became a partner with the Regional Social Services Emergency Response group.

Examples of Amateur emergency situation assistance are frequently mentioned in association with hurricanes, severe tropical weather disasters and major flooding, in both Canada and the United States.

A major, but not exclusive illustration, is Hurricane Katrina which, in 2005, became the third most deadly hurricane in the history of the United States.

The following item was published shortly thereafter in various American newspapers.

"Volunteers from Amateur Radio's emergency service wing, the Amateur Radio Emergency Service, provided communications infrastructure had been damaged or totally destroyed, relaying everything from 911 traffic to messages home. In Hancock County, Mississippi, ham radio operators provided the only communications into or out of the area, and even served as 911 dispatchers."

Source: *The American Radio Relay League (ARRL), the national voice of American Amateur Radio*

The US Federal Emergency Management Agency (FEMA) has endorsed American Amateur Radio and supplied considerable funds to support American Amateur groups with equipment upgrades.

Kitchener-Waterloo ARC members assisted at the New York World Trade Towers disaster, during the later stages of the NYC World Trade Centre disaster relief program in September 2001. One of our members spent a week assisting one

QSL Cards
Canadian QSLs by VE7DK
since 1956

Special deal on full colour
photo-type cards
Small quantities available

Choice of card stock and finish
Colour, logos, photos available
Reasonable, competitive prices

Dennis Livesey, VE7DK
8309-112th Street, Delta BC V4C 4W7
604-594-6675 – denliv@telus.net

of the major service providers in the city. Initially on standby as a welcomed general helper, he was asked shortly thereafter if he would manage the operations of this particular facility for several days. His assistance was greatly appreciated.

We certainly don't anticipate a disaster of this magnitude here in Waterloo.

EMERGENCY RESPONSE PLANS AT THE LOCAL LEVEL

Radio Amateurs of Canada, our national organization, has been actively developing Amateur Radio emergency communication training programs, and working on Memorandums of Understanding (MOUs) with various levels of government. So much so that, in formulating organizational policy at the local level, the Provincial Government encouraged that Amateur Radio involvement be written into the original Region of Waterloo Social Services Emergency Response Plan operations binder (published in May 2006). We are currently referenced in six different places throughout the document.

I was pleased to be contacted by the Regional coordinator of Emergency planning, in its formative stage, about the Kitchener-Waterloo ARC's participation with the Region. Unusually, I only recently received documents describing one of our very earliest participations in an Emergency Management Ontario (EMO) exercise with the then Waterloo County EMO, dated 1971.

ON ROAD RESTRICTIONS

Cellphones, Two-Way Communications and Amateur Radio

An Ontario Provincial law, promulgated in 2012, regulating mobile use of "Display Screens and Hand-Held Devices" was amended at the request of Radio Amateurs Canada, to allow the continued use of mobile Amateur radios in a moving vehicle. The major argument, presented successfully, was that Amateurs could provide valuable services in emergency situations.

"We already have very sophisticated communications equipment within our Agency/Organization. So why might we need this rather arcane method of communications?"

For starters, the "arcane" factor may in fact be an asset. All amateur Radio equipment operates on a 12-volt power supply. This can be via a mains transformer or an independent battery.

Cellphones?

Experience has proven that the chances of a system crash increase dramatically with mass use of the limited cell channels in disaster situations, i.e., the cell system fails. If a critical relay tower loses power or is damaged, the system fails.

Municipal agency radios – mobile or otherwise – are licensed to use only a few specific frequencies. But they can readily become overloaded. Moreover, various emergency agencies may be unable to interact with other agencies to transfer critical information.

Amateurs, on the other hand, are able to access a wide variety of exclusive frequencies/channels, and are also able to function with an independent power supply. When needed, the use of our Club Repeaters can expand the contact zone to about a 60 kilometre radius. We are virtually fail safe.

"Can these volunteers really help; and not get in the way?"

The Kitchener-Waterloo Amateur Radio Club offers courses annually in the operation and etiquette of using these regulated RF airwaves.

Amateur Radio operators must pass a lengthy industry Canada certification test. It is illegal for a person not certified by Industry Canada to operate on Amateur Radio frequencies, without a certified operator in attendance. The availability of Amateur Radio serves as a reliable backup to agency equipment. Moreover, you will have a trained radio operator, complete with his/her own equipment – an additional asset in the event of a worst case scenario.

WHAT WE DO

We transmit messages and await a response. We might even be called high class "paper pushers".

A no-cost volunteer can be especially valuable in this day of constrained public service personnel hiring.

We maintain a volunteer roster of "Willing, and Able, If Available" radio operators. Every spring we run a simulated emergency training exercise to keep our message passing skills up to date.

For How Long Would We Be Available?

Many service agencies are served by short-term volunteers. It has been estimated that in a disaster, most official emergency management systems are back to being fully operational in about three days, at which point these systems are functioning smoothly.

A SIMPLE DESKTOP STAND



Here is a suggestion for a simple Desktop Stand for your HT.

The availability of lower cost handhelds (HTs) today makes it feasible to dedicate one HT just to monitor one or more VHF/UHF channels.

The unit shown in the photo is mounted – using its belt clip – to a readily available clear acrylic photo display stand.

The battery was replaced by the DC cigar lighter adapter available for it.

The stand I used was intended for 4" x 6" photos – the kind in which a photo can be slid in between two closely spaced acrylic pieces – and cost \$1.25 at the local "dollar" store.

On the top edge, I used my bandsaw to carefully cut a vertical slot about 1 inch wide by 1.5 long, to accommodate the HT's belt clip.

It's important to get the HT as low as possible on the stand to reduce its tendency to tip. This particular stand was kind of "tippy" so, to further improve the stability, I added an aluminum base, about 4" x 3", cut from 3/8-inch aluminum plate.

A final touch was to use two of my blank QSL cards, appropriately cut and inserted in place of a photo, just to improve the overall appearance.

To be fair, this great but simple idea is attributable to the late David Faul, VE3TIJ, who sadly became a Silent Key on December 9, 2012.

Don Dorward, VA3DDN
Pickering, Ontario

THE VALUE OF A CERTIFIED EMERGENCY COORDINATOR

Submitted by Bill Boskwick, VE4BOZ (CEC)
RAC Chief Field Services Operations
Certified Emergency Coordinator



**What do Amateur Radio operators do best?
We communicate. Never lose sight of that –
ever!**

Are we “tekies” – somewhat but not in a negative way.

We want to be able to communicate under as wide a range of conditions as we are allowed to explore.

With this in mind, we tap into the roots of “ham radio” because it all began with technically minded people tinkering with electronics and coming up with radios they could build themselves and use to communicate with other like-minded people. And it grew from there.

Today we collectively share a unique place in the telecommunications environment globally.

We are acknowledged as proficient communicators, capable of passing information under a wide range of conditions, regionally, nationally and globally.

In Canada we have Radio Amateurs Canada (RAC) as our national representative and champion. RAC does not dictate nor does it impede. It does its best to act in the best interests of Amateur Radio as a hobby and a national asset on behalf of not only its members, but Amateur Radio operators generally, in Canada.

Relating to emergency management and the role of the Amateur Radio Emergency Service (ARES), our focus is on being able to establish and sustain a reliable communications net at local, regional or national levels.

It isn't “mission critical” for our ARES operators to have an intimate understanding of the nuances of Incident Management System (ICS) or Emergency Site Management (ESM) or whatever, but *it is critical* for those operators to have a sound understanding of the radio net they are working on, how to set it up and how to record and track all message traffic.

That's the bottom line. That's what we should strive to attain and what we should be practising locally, regionally and nationally.

The Certified Emergency Coordinator (CEC) is the Section Manager's (SM) best resource to help develop this asset in his or her Section. The CEC has attained that designation and recognition by study and writing an examination that validates his/her understanding of the role of a CEC. This is a national Standard, recognized across the country and is an assurance that uniformity in communications will be maintained.

For more information on how to become a Certified Emergency Coordinator please visit the RAC website:

<http://wp.rac.ca/welcome/certified-emergency-coordinator/>

RAC SIMULATED EMERGENCY TEST

SATURDAY, OCTOBER 10

Note: In Ontario the Simulated Emergency Test will be held on Wednesday, October 7.

This nationwide exercise is the chance to test your emergency operating skills and the readiness of your communications equipment and accessories in an emergency-like deployment.



RAC Field Organization Leaders at the Section and local levels, along with many other volunteers who are active in public service and emergency communications, are developing simulated emergency scenarios in consultation with served agencies.

To find out how you can step up and be a part of the local or Section-level activities, contact your Section Manager. You can find contact information for all RAC Section Managers on page 4 of any issue of *The Canadian Amateur*. Additional contact information may also be found on the RAC website.

The Amateur Radio Emergency Service (ARES) and the National Traffic System (NTS) and members of the RAC Field Organization will participate and practise emergency operation plans, nets and procedures.

The RAC Simulated Emergency Test is an ideal opportunity to demonstrate the capabilities of Amateur Radio.

Community and public service agency officials will learn first-hand by taking a role in the SET and by providing an objective evaluation afterwards from their perspective. Have designated stations originate messages on behalf of served agencies. Test messages may be sent simulating requests for supplies. Simulated emergency messages (just like real emergency messages) should be signed by an authorized official.

Formulate your plans around a man-made or natural simulated disaster. Possible scenes could be: a flood; a serious fire; a severe ice storm; a missing person; a serious accident (automobile, bus, aircraft); a broken gas line; or any other imaginable disaster. Elaborate on the situation by developing a scenario to be implemented during the SET.

In consideration of local and Section-wide schedules with agencies and many others, RAC Field Organization Leaders have the option of conducting their local or Section-wide SET on another weekend in the fall season. Check with your local RAC Field Organization leadership for the exact date in your particular area. Your help is needed and the RAC SET is a great way to get involved in emergency communications.

For more information on guidelines, preparing and reporting for a SET, forms for RAC Field Leaders are posted on the RAC website at:

<http://wp.rac.ca/welcome/simulated-emergency-test/>

“A Beautiful Voice Was Heard Coming from Space”

SATS and SHARP: Shaftesbury ARISS Telebridge Service and Shaftesbury High Altitude Robotics Project

Submitted by Robert Striemer, VE4SHS

Students of Shaftesbury High School in Winnipeg, Manitoba conducted their first radio contact with an astronaut on the International Space Station (ISS) on May 23 between 6:29 and 6:40 am (orbit 94419).

Several students – Dylan, VA4DFJ, Bryce, VE4VBC, Navjot, VE4NSD, Jordan, VE4JRB, Kendra, VA4MCT, Tara, VE4TET and Victoria, VA4VRD, who are all certified Radio Amateurs – spoke with European Space Agency Astronaut Samantha Cristoforetti, IZ0UDF, who is also the first Italian woman in space.

The students asked Samantha about her life aboard the ISS using Shaftesbury’s Amateur Radio satellite tracking station VE4ISS. No press were able to attend the event but our students made video recordings. This was the first check of our station’s ability to perform ARISS (Amateur Radio on the International Space Station) contacts that will link schools and students around the world to an astronaut on the ISS via the Shaftesbury station. The students performed very well and made us very proud.



The signal from the ISS was generally good and Samantha gave us a glowing reception report as did Dave Taylor, W8AAS, representing ARISS in Baltimore, Maryland. We expect that ARISS will certify VE4ISS ready to conduct regular school contacts soon.

The contact was a big step forward in what has been a two-year long process of building the station and developing the skills needed to make it all work. Needless to say, our students and the staff were very excited by the whole experience.



A video clip of our first ISS contact (revised) can be viewed at <http://shsballoonproject.pbworks.com/>. Thanks Bryce! The audio received from Samantha on the ISS is not great in the video clip since the GoPro camera used to record the contact is sitting on top of the Kenwood TS-2000 and the speaker is on the shelf above. Until next time...

The above photos show the happy faces on the ground station, on the speaker phone at Shaftesbury High School and on the International Space Station.

For more information on SATS and SHARP please visit the following site: <http://shsballoonproject.pbworks.com><<http://shsballoonproject.pbworks.com/>

Viewing Whitehorse from Above: Welcome to Haeckel Hill

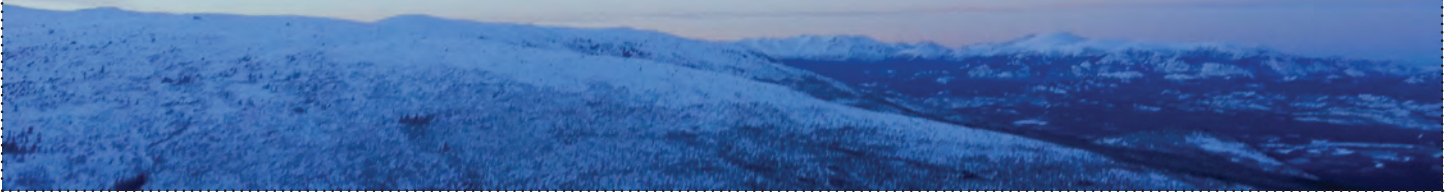

Submitted by Ron McFadyen, VY1RM
RAC Assistant Director, Yukon Territory

“Of all the mountain or hilltop viewpoints in the Whitehorse area, Haeckel Hill is one of the most noticeable. The two Yukon Energy wind turbines atop the hill make it a very distinctive landmark. At a height of 1,433 metres above sea level or about 800 metres above the Yukon River, this site offers an unusual opportunity to join the soaring eagles for a great birds’-eye view! Appropriately, the Southern Tutchone name for this height of land is Thay T’äw, meaning ‘eagle nest’...At the top of Haeckel Hill, you can crouch down to see the rocks and lichens, or stretch your view to distant mountain peaks. You can observe the results of geological processes that span over 200 million years. Change still occurs at rates so slow, it is difficult to notice.”

The above information is from “Viewing Whitehorse from Above: A Guide to Haeckel Hill and Thay T’äw”, which is provided by Yukon Energy for their site located within a kilometre of the Yukon Amateur Radio Association’s repeater site on Haeckel Hill. This is the home of YARA’s D-Star repeater (VY1RDS) IRLP (1500 on 146.88) and link repeaters which overlook Whitehorse from a height of about 3,000 feet. All YARA repeaters require 100 tone.

The photos were taken by YARA member Paul Getson, VY1PG, while Paul and Scott Williamson, VY1SW (YARA Past-President), were doing maintenance at the site despite the -30 C conditions. Access by snowmobiles only.

This building houses YARA VHF and UHF links to the south and north to access the wide area network. This repeater is also a Link to IRLP located at Yukon College on UHF.

Also located at the site is a UHF commercial repeater owned by YARA but donated to the Whitehorse Cross Country Ski Club.

To the south and not shown in the photos is the D-Star 1.2 GHz comms and Data antenna.

All repeaters were obtained from Daniels Electronics (now a part of Codan) in Victoria, British Columbia and are owned and maintained by YARA. The building shown in the photos is an insulated refrigeration unit from Matco Transportation and it is perfect for our gear.



The photo above shows the Sinclair (Black) V antenna for D-Star.

The windmill shown in the background is located at the nearby Yukon Energy site.

The photo on the left shows the entrance to the refrigeration unit we use as an insulated building for all of our equipment.

It is warm in winter; -5 C inside when it is -40 C outside and about a maximum 25 C in summer.

It measures 8 ft x 8 ft x 8 ft.



"An interesting adventure..."

Submitted by Ron McFadyen, VY1RM
RAC Assistant Director, Yukon Territory

"Made it to Klukshu on Saturday to replace the Repeater there. It was an interesting adventure as the weather was not ideal.

We called the helicopter at about 7:30 am and were in the air around 8 am. The helicopter was able to drop us (went with a Park's guy named David Blakeburn) at the top close to the comshell. The wind was fierce – likely 80 km/h or so. Temperature was a few degrees below zero.

As there were lower clouds moving in and out, the helicopter couldn't wait for us so we departed and found a nice flat spot a few hundred metres below. We did the repeater swap and tested everything as quickly as possible as the heli had a deadline for another job.

Once completed we hiked/scrambled/climbed down to where the helicopter was (fun with my 60 to 80 lb pack with tools and old repeater) and were back at the staging point before 10 am.

Everything seems to be operating well. We should be in good shape for the bike race. We are still hoping to get Chilkat done in time but nothing is scheduled yet.

Thanks to VY1RF for the signal checks."

The above message is from Scott Williamson, VY1SW, one of our super volunteers on a trip to a 7100-foot mountain, South of Haines Junction (about 100 miles west of Whitehorse and about 50 miles south of Haines Junction).

This repeater is crucial to the coverage of the Kluane Chilkat International Bike Relay which was held on June 20.

The Yukon Amateur Radio Association (YARA) provides emergency and general communications coverage of the 150-mile race from Haines Junction to Haines, Alaska.



We have repeaters along the entire distance of the race – all part of the Yukon Amateur Radio Association's Wide Area Network (<http://www.yara.ca/>).

About 1200 to 1500 Cyclists in teams of 1, 2, 4 and 8 try the distance.



Dealing with Radio Frequency Interference (RFI)

Gary Bartlett, VEIRGB

We are blessed (in Nova Scotia, at least) by having a power company that takes a genuine interest in solving the types of interference problems generated by their power distribution system, however they cannot work miracles.

The chances of having these types of problems solved increase by an order of magnitude if the Radio Amateur operator does the initial localization of the noise source.

The process of narrowing down such noise sources does not necessarily involve exotic electronics or complicated procedures. It does, though, require a scientific approach and plenty of common sense.

The following simple instructions are based on real-world experience in locating electrical power distribution system noise sources. While the instructions below are aimed at locating that specific type of problem, the techniques are applicable to noises generated by sources other than those from your local power company (for example, the electric fence operated by my neighbour's farm).

Caveat: Electrical noises do not necessarily radiate from the source. Sometimes the noise will be generated in one location, but propagate along power feeders and begin the actual emission into the ether at some other place such as, say, a guy cable on a power pole that is acting as an antenna. Good luck finding those sources.

Step 1. Keep a journal. In order to characterize intermittent noise, record the details of the noise every time it is encountered. Take those notes for as long as is necessary to be able to predict the conditions under which the noise will occur. That could take a month or more in some instances.

Record the day of the week, the time of day at which the noise starts and goes away, the season of the year, the bands involved, a description of noise (pulsing; continuous, etc), the relative noise strength as read off a receiver's S-Meter, the weather conditions (temperature and precipitation or lack thereof), and any other factors which might seem to be

Note: This article first appeared in the Halifax Amateur Radio Club's newsletter "Reflector" and it is being included here with their permission.

relevant. An amazing number of conclusions regarding the noise source can be drawn from this information alone. If nothing else it may help in determining if the noise source really is the power company or, rather, it is from your neighbour's new plasma television.

Here is a simple example:

One residential noise source tended to occur daily after 4 pm during the week, quit in the late evening, and be continuous all day long on the weekend. It was significantly more pronounced on very hot days. Conclusion: a breakdown of an electrical insulator when people came home after school and after work and started turning on appliances – especially air conditioning units. The additional electrical load on the power distribution system was the trigger.

Step 2. Use your antennas – all of them – to try to determine the direction from which the noise is radiating. Rotating antennas and reversible Beverages and K9AY loops are invaluable in assessing the compass heading to the noise source.

Step 3. When you are experiencing the noise in the station, go to your car, turn the radio on to the broadcast band (AM), and start driving in ever-expanding circles around your station. You will hear some pretty loud and disturbingly strong noises from lots of places, but when you come to the noise source you are looking for there will be little mistaking it. It will stand out from the crowd. This will narrow down the general location of the noise source.

Step 4. Once you have the general area, walk around with a battery-powered HF (shortwave) receiver with a whip antenna to try to narrow down, even more, the area located in Step 3. Tune the radio to the worst band as identified in your station.

Step 5. Once the general area of the noise source is known, then take a handheld radio capable of operating in the VHF AM air-traffic control band – say at about 135 MHz – and walk the area. No self-respecting noise source will escape the attention of this device. That technique can prove accurate to the point where one can identify the pole or other component from which the noise is actually radiating. Record the location and pole number.

Step 6. It may be assumed that that an arcing noise source will produce audible noise as well as electrical noise. There are inexpensive ultrasonic noise detectors on the marketplace that can hear that noise. Even the cheap ones will be accurate enough to point to the actual component from which acoustic noise is coming. Find one of those ultrasonic receivers and when you are not listening for "bats", repeat Step 5 with it as a means of even more accurate localization or at least corroboration of what has been surmised up to this point.

When, and only when, these steps have been carried out, document all of those findings in a simple report and contact the Engineering department of your local power company and forward them the report. Industry Canada provides a list of contact numbers for power companies across Canada: <http://www.ic.gc.ca/eic/site/smt-gst.nsf/eng/sf10641.html>.

The person assigned the RFI sniffing task will then want to meet with you and visit the source that you have tentatively identified. They have much better test equipment than most Amateurs and will be able to verify or reject your conclusions. If you are lucky, you will have found the exact source, the power company engineer will agree with it, and he or she will then raise a work order to have the noise corrected. That can take a while (two or three weeks).

If it is determined that the RF noise is *not* being generated by the power company, then you are faced with attempting to fix the noise problem through dealings with the private or business owner from whence the noise is coming. The proper means of dealing with interference under those conditions are well documented by Radio Amateurs of Canada and other organizations. Stated in simple terms, it may be the other guy's fault but resolution is quite likely to be up to your own initiative. Patience and a level temperament will prove critical.

Summary: Identifying noise sources is a process of deductive, Sherlock Holmes, work followed by localization using tools readily available to most Amateurs. Resolution is *significantly* more likely if you can do the preliminary work to identify the source and location of the noise. The power utility will love you for it.

THE SPORTS PAGE

— THE CANADIAN CONTEST SCENE



Bob Nash, VE3KZ
5260 14th Sideroad, RR6
Milton, ON L9T 2Y1
Tel. 905-878-7382
Email: ve3kz@rac.ca

SPORTS PAGE INFO:

For more contest information check out these sites:

<http://www.hornucopia.com/contestcal/weeklycont.html>

<http://www.contesting.com>

<http://www.sk3bg.se/contest/>

<http://www.arrl.org/contests/calendar.html>

<http://www.arrl.org/contests/rate-sheet/about.html>

<http://www.cq-amateur-radio.com/awards.html>

http://www.arrl.org/files/file/DXCC/2013%20DXCC%20Current_a.pdf

The "Contest Calendar" at the end of this column is presented as a guide only.

RAC and TCA do not necessarily endorse or support any of the contests or the accuracy of the information.

Bands: The 30, 17 and 12m bands are never used in any contest.



For the RAC Store visit:
http://www.cafepress.ca/rac_radio

CHECKING THE CONTEST LOGS

The way logs are checked has certainly changed over my watch in the many contests in which I have participated. Even today there is a tremendous variation from one contest to another and with good reason.

One of the reasons has to do with the size of logs. Small logs can often be visually scanned for obvious mistakes. Any small errors left in the log will be of little consequence. If there are logs that are very close to one another for an award, it just takes a bit more eye-strain to make sure of the "winner". A small QSO Party can survive using this technique. For these contests, it is also worthwhile to employ a software program to re-score logs. Not everyone in such a QSO Party necessarily has software designed for it and there is often the "not read the rules for scoring" problem.

As we go up the ladder of contest size, the computer becomes a cross-checker and identifier of incorrect calls. At the top of the contest heap we find the CQWW contests.

The World Wide Radio Operators Foundation (WWROF) has committed itself to provide the entire infrastructure for these contests, everything except the printing in the CQ magazine!

With the largest participation of all the contests, there is a prestige to winning that encourages those who are ethically challenged to seek this prestige by a number of practices not allowed in the rules. WWROF has gone to a great deal of trouble to identify these practices.

For 2014, the logs for the CQWW DX contests have been scrutinized using the best techniques available including wideband SDR recordings of the bands. This resulted in the disqualification of 30 stations in the CW contest with an additional 8 warnings issued. On SSB 24 stations were disqualified and 39 warnings.

The offences tabulated were:

- Unclaimed assistance when operating Non-Assisted
- Power >5W when operating QRP
- Time shifting to meet band change rule when operating Multi-Single
- Unverifiable QSOs
- Wide signal
- Self-spotting
- Transmitting outside of licence limitations

Only 5 of the 101 stations cited were in North America including only one in the United States and *none* in Canada. This is a tribute to the several Canadian stations that stood high in their category. Congratulations!

SUMMER ACTIVITY

After Canada Day, the biggest attraction is the IARU HF World Championship attracting over 100 Canadian operators. Each contest has its individual challenges. The DARC WAE contest has its QTCs. The RSGB IOTA contest has its island multipliers. Give your name in the NAQP Parties. Enjoy a VHF contest, a UHF contest and a Microwave contest. You have three RTTY contests for the diddle enthusiasts.

HELP!

I will gladly consider any assistance in the form of a guest columnist or results compiler. Please contact me (ve3kz@rac.ca) or the TCA editor (tcamag@yahoo.ca) and let us know what you have in mind. Many thanks in advance!

73, Bob, VE3KZ



ARRL AUGUST UHF CONTEST

Call	QSO	Mult	Score	Category
VE3OIL/R	81	34	12,036	Rover
VA3ST	35	20	3,180	SOHP
VE3DS	23	12	1,152	SOLP
VE3CRU/R	21	12	864	Limited Rover
VE3WY	13	10	420	SOLP
VE2PIJ	13	8	360	SOLP
VE7AFZ	1	1	3	SOLP

SARTG WW RTTY CONTEST

Call	QSO	Mult	Score	Category
VE4EA	420	5455	660,055	SOABHP
VE7IO	396	5165	645,625	SOABHP
VE5MX	377	5030	593,540	SOABHP
VE3FH	310	3960	578,160	SOABLP
VE2FK	221	2890	277,440	SOABHP
VA2UP	213	2815	230,830	SOABHP
VE2FU	206	2550	265,200	SOABLP
VE2NMB	183	2325	227,850	SOABHP
VE2EBK	181	2280	239,400	SOABLP
VA7ST	172	2185	222,870	SOABLP
VE3EY	130	1875	106,875	SOABHP
VA6AK	124	1685	131,430	SOABLP
VY2MP	117	1525	108,275	SOABLP
VE4VT(VE4EAR)	98	1205	78,325	SOABLP
VE7FCO	56	680	25,160	SO20
VE9BWK	47	625	21,250	SOABLP
VE2HB	53	620	14,260	SOABHP
VE6SQ	33	355	8,165	SOABLP
VA7JC	17	230	3,450	SO20
VE3AJ	13	160	1,600	SO20

DL-DX RTTY CONTEST

Call	QSO	DXCC	Area	Score	Class
VA7KO	590	93	61	1,266,650	Single-Op
VA2UP	460	90	51	852,345	Single-Op-Unlim
VE7SZ	486	79	43	785,070	Single-Op
VA7ST	393	77	52	703,050	Single-Op
VE2EBK	301	72	42	457,710	Single-Op
VE2FU	277	65	43	370,440	Single-Op-Dipole
VE3AJ	204	57	31	227,040	Single-Op-Dipole
VE2NMB	132	55	26	140,130	Single-Op-Unlim-6-H
VE2FK	167	42	18	129,900	Single-Op
VE6SQ	117	26	42	87,040	Single-Op-Dipole
VA3IK	66	27	19	37,490	Single-Op-Dipole
VA7AQD	55	23	26	30,625	Single-Op
VE3RCN	54	18	22	24,600	Single-Op-Unlim
VE3MCF	59	17	12	20,300	Single-Op-6-H
K7MKL/VE4	43	10	16	11,050	Single-Op-Dipole
VA7JC	37	10	16	9,490	Single-Op-Dipole
VE2QV	28	10	10	6,200	Single-Op-Unlim-6-H
VY2LI	28	7	10	5,015	Single-Op

CQ WORLDWIDE VHF CONTEST

Call	QSO	Grid	Score	Class
VE7XF	10,816	169	64	SO6
VE7DAY	8,322	142	57	SOAB
VA7FC	6,448	124	52	SO6
VE3SMA	6,084	82	52	MO
VA2EW	3,256	74	44	SO6
VE5UF	2,904	66	44	SO6
VE3MMQ	3,360	80	42	SO6
VE7JH	3,465	70	35	SOAB
VE4VT	806	31	26	SO6
VE2NGH	1,274	45	26	MO
VA2LGQ	560	23	20	MO
VE3EG	627	24	19	MO
VE3DS	442	19	17	SOAB
VE3AAQ	288	18	12	Hilltopper
VE1SKY	143	11	11	SOAB
VE3IQZ	136	11	8	SOAB
VE3RX	88	8	8	SOAB
VE6UM	64	8	8	SO6
VE3CX	56	8	7	SO6
VE3RKS/R	91	8	7	Rover
VE3GTC	48	8	6	SO6
VA3PC	16	4	4	SO6
VA7MM	32	5	4	SO-QRP
VA3MTT	24	4	3	SO2
VA2EN	8	4	2	SO6
VE5DL	4	2	2	SO-QRP
VE2PIJ	2	2	1	SO6
VE3RCN	1	1	1	SO6

ARRL 10 GHZ AND UP CONTEST

Call	Score	QSO	DIFFNT	QSO	Distance	Points
VE3SMA	10,243	70	23	7,943		
VE3MSC	3,899	35	14	2,499		
VA3TO	3,276	14	13	1,976		
VE3NPB	3,181	17	12	1,981		
VE3NYZ	3,119	21	12	1,919		
VE3CRU	1,803	12	5	1,303		
VE3KH	1,665	9	9	765		
VE3FN	1,544	3	3	1,244		
VE3OIL	909	8	7	209		

KANSAS QSO PARTY

Call	CW	PH	DIG	Mult	Score
VE9AA	235	76	0	93	79801
VE5KS	51	27	0	53	11071
VA3GKO	0	82	0	45	7380
VE6UM	40	10	0	38	5320
VE3HED	0	39	0	25	1950
CF3NAVY (VE3RCN)	3	13	1	14	532
VA3PAW	8	11	0	10	460
VE3PQ	0	12	0	9	216
VA3RKM	7	0	0	5	105
VE2PIJ	0	7	0	6	84
VA7AQD	0	4	0	4	32

WAE DX CONTEST, CW

Call	QSO	Mult	Score	Class
VE3AT	1,934	381	1,477,899	SOHP
VA2EW	1,749	363	1,273,041	SOHP
VE3DZ	1,477	324	959,688	SOHP
VO2MW	821	256	420,608	SOLP
VE3UTT	634	235	300,800	SOHP
VE3RZ	640	228	287,508	SOHP
VY2SS	580	213	249,636	SOHP
VE3TA	588	165	196,020	SOHP
VE7UF(VE7JH)	557	172	189,716	SOHP
VE5MX	459	166	155,376	SOHP
VE3TG	359	186	131,130	SOLP
VE2FU	337	174	119,538	SOLP
VE2FK	293	186	109,740	SOHP
VE3KI	200	180	71,820	SOHP
VE3IAE	214	142	60,634	SOLP
VA7ST	244	114	56,088	SOHP
VA3EC	235	118	55,814	SOLP
VE1OP	251	108	53,784	SOHP
VE9AA	162	102	33,048	SOHP
VE3RSA	130	119	28,560	SOLP
VE3FJ	192	105	28,035	SOHP
VE2AWR	126	85	21,505	SOLP
K2NV/VE3	96	88	17,072	SOLP
VE3EY	113	72	16,560	SOHP
VA2WA	117	60	14,100	SOLP
VE7IO	90	64	12,288	SOHP
VE3CX	81	75	12,000	SOHP
VO1BQ	131	83	10,873	SOLP
VE4VT(VE4EAR)	76	64	9,536	SOLP
VE9OA	58	72	8,712	SOLP
VE2QV	61	68	8,160	SOLP
VE6UX	102	74	7,548	SOHP
VE9BWK	72	49	5,978	SOLP
VE2EZD	35	53	3,498	SOHP
VA3FN	55	60	3,300	SOLP
VE7ACN	51	30	1,530	SOLP
VE7BGP	34	26	884	SOLP
VA3RKM	17	26	702	SOLP
VE2JR	13	18	234	SOLP

JULY NORTH AMERICAN QSO PARTY, RTTY

Call	QSO	Mult	Score	Class
VE5MX	472	124	58,528	SOAB
VE3JI	420	131	55,020	SOAB
VE3RZ	388	127	49,276	SOAB
VE4EA+VE3KI	417	116	48,372	M2
VE4VT(VE4EAR)	380	120	45,600	SOAB
VE3CX	345	132	45,540	SOAB
VA3XH	370	118	43,660	SOAB
VE7IO	376	115	43,240	SOAB
VA7KO	347	104	36,088	SOAB
VE3UTT	311	110	34,210	SOAB
VA7AM	326	104	33,904	SOAB
VE5KS	304	105	31,920	SOAB
VA7ST	317	93	29,481	SOAB
VE3AJ	182	61	11,102	SOAB
VE6AX	148	73	10,804	SOAB
VE3IAE	155	67	10,385	SOAB
VE6QO	131	63	8,253	SOAB
VA2QR	115	68	7,820	SOAB
VE2EZD	114	59	6,726	SOAB
VA1CHP	117	57	6,669	SOAB
*VE3XD	115	56	6,440	SOAB
VE3HG	99	59	5,841	SOAB
VE6SQ	90	53	4,770	SOAB
VE3RCN	87	48	4,176	SOAB
VE3MGY	98	35	3,430	SOAB
VA3IK	59	30	1,770	SOAB
K2NV/VE3	47	31	1,457	SOAB
VE7WJ	41	28	1,148	SOAB
VE2NMB	45	21	945	SOAB
VA7AQD	31	23	713	SOAB
VE7FCO	32	20	640	SOAB
*VA3RKM	22	20	440	SOAB
VE7QC	22	13	286	SOAB
*VA3PCJ	19	13	247	SOAB
*VE6UM	9	7	63	SOAB

Note: in the chart above an* = QRP

IARU HF WORLD CHAMPIONSHIP						VE7NA	77	46	10,810	HP	MS
Call	QSO	Mult	Score	Power	Class	(VA7DSW,VA7DGV,VE7BGP)					
VY2RAC	6,119	291	6,884,769	HP	HQ	VA2EN	64	54	8,964	HP	MS
(N0AT,K0BBC,VE3RZ, ops)						VE7TJF	73	41	8,569	LP	SO SSB
VE3AT	3,187	247	3,222,115	HP	SO Mixed	VA3RKM	70	33	5,676	QRP	SO CW
VE3JM	2,988	229	2,767,694	HP	SO CW	VE3MEW	51	31	5,425	LP	SO SSB
VA2EW	2,262	223	2,090,848	HP	SO CW	VE6JY	52	36	5,040	HP	MS
VE3OI	1,945	182	1,333,150	HP	SO Mixed	VE3NRT	47	31	4,371	HP	SO SSB
VE7ZO (@VE7UF)	1,757	209	1,283,469	HP	MS	K2NV/VE3	57	26	3,874	LP	SO CW
(+VE7KW,VE7ACN,VE7UF)						VA3AH	75	15	3,825	LP	SO Mixed
VE3BR	1,063	168	624,792	LP	SO Mixed	VA7AM	37	31	3,689	LP	SO SSB
VE1RGB	955	182	596,778	LP	SO CW	VE3KZ	248	4	2,976	HP	SO Mixed
VE4EA	1,321	129	567,987	HP	MS	VA3FN	31	19	1,691	LP	SO CW
(+VE4SNA & VE4DRK)						VE2QV	29	16	1,520	LP	SO CW
VA7ST	1,224	120	528,240	HP	SO CW	VE7TI	24	17	1,462	LP	SO SSB
VE3CR	759	194	502,654	HP	SO CW	VE3OKK	27	19	1,425	HP	MS
VE7SZ	1,082	99	363,924	HP	SO SSB	(+VE3ZJS & VE3WMT)					
VE7NY (+N7QT)	975	99	359,073	HP	MS	VE3MCF	27	16	1,328	LP	SO SSB
VE1DT	582	143	294,580	HP	SO CW	VE3TA	99	4	1,188	HP	SO CW
VA7KO	689	114	279,870	HP	SO CW	VE3VCF	25	17	1,037	LP	SO CW
VA3SB	561	138	256,818	QRP	SO CW	VA7HZ	19	19	931	HP	SO Mixed
VE4YU	634	121	233,530	LP	SO Mixed	VE4DPR	32	9	828	LP	SO SSB
VE3IAE	562	125	221,250	LP	SO CW	VA3NGE	25	10	730	LP	SO SSB
VO1MP	452	137	217,008	HP	SO CW	VE3AJ	17	17	697	LP	SO SSB
VE2AWR	546	122	210,328	LP	SO Mixed	VE3HX	93	2	558	LP	SO Mixed
VE1WOW (K1WO, op)	373	156	204,672	LP	SO SSB	VE4DRK	16	12	552	LP	SO SSB
VE3TW	507	125	199,625	HP	SO Mixed	VE5DLD	22	7	448	QRP	SO SSB
VE3UTT	369	161	198,513	HP	MS	K7MKL/VE4	24	6	420	LP	SO SSB
VE7JKZ	483	116	190,588	HP	SO CW	VE3NLE	3	3	45	LP	SO SSB
VE3VE	344	125	162,500	LP	SO SSB						
VE3KP	442	118	160,952	HP	SO Mixed						
VE6BF	456	103	149,762	LP	SO CW						
VA1MM	502	83	144,586	LP	SO CW						
VA3GKO	387	121	144,353	LP	SO SSB						
VE4VT (VE4EAR, op)	465	103	143,891	LP	SO Mixed						
VE3FH	341	117	124,605	LP	SO CW						
VE3FJ	328	95	117,990	HP	SO CW						
VA3ZNQ	284	119	106,862	HP	SO SSB						
VE3MV	265	102	96,798	LP	SO SSB						
VA6AM	340	84	90,384	LP	SO CW						
VE3KTB	265	100	83,900	LP	SO SSB						
VE2FU	323	84	82,572	HP	SO CW						
VE3MGY	569	47	82,391	LP	SO CW						
VA7CRZ	298	81	78,246	LP	SO CW						
VC6IARU	383	63	73,395	HP	Admin. Council						
(VE6SH,VE6CCL,VE6OH)											
VE3BZ (+VE6WQ)	353	50	71,950	HP	MS						
VE3DVF	253	90	70,830	LP	SO Mixed						
VE6UX	202	92	69,552	HP	SO CW						
VE3IRR	262	71	64,326	HP	MS						
VE9DX	391	51	58,599	LP	SO CW						
VE3CX	244	70	51,940	HP	MS						
VA3TPS	203	81	49,815	LP	SO SSB						
VE2EBK	237	73	45,917	HP	MS						
VE5KS	165	84	44,100	LP	SO CW						
VA3ATT	190	71	41,890	LP	SO CW						
VA2QR	143	84	37,380	HP	MS						
VE7IO	255	43	35,303	HP	MS						
VE2FK	182	58	33,872	HP	SO CW						
VE6AX	171	64	33,600	HP	MS						
VE5UO	216	46	30,084	LP	SO Mixed						
VA3PAW	211	47	29,187	LP	SO Mixed						
VE3XD	188	51	28,458	HP	MS						
VA3EC	140	64	26,880	LP	SO CW						
VE3LJQ	125	65	26,065	LP	SO SSB						
VE3ZY (VE3FFK, op)	156	57	25,194	LP	SO CW						
VE2PIJ	129	60	24,780	LP	SO SSB						
VA3GD	127	57	23,199	LP	SO SSB						
VE2CJR	128	59	22,538	LP	SO SSB						
VE3RCN	132	52	20,072	LP	SO Mixed						
VA3MTT	111	52	18,564	HP	SO Mixed						
VY1JA	122	45	17,550	HP	SO CW						
VE3RHE	94	55	17,270	LP	SO SSB						
VE3VN	108	44	14,784	QRP	SO CW						
VA7KH	76	54	13,284	HP	MS						
VE3DTI	100	47	13,160	QRP	SO CW						
VE3HED	85	58	13,050	HP	SO SSB						
VE1NB	113	33	11,517	LP	SO CW						
VA3EON	96	41	11,398	LP	SO CW						
VE2HIT	77	42	11,298	LP	SO SSB						

RSGB IOTA CONTEST					
Call	QSO	Mult	Score	IOTA	
VY2TT	2540	264	5,187,600	NA029	
VC1S	1407	272	3,178,320	NA126	
VE3KI	189	118	311,520		
VO1KVT	355	57	160,455	NA027	
VE3ZZ	164	81	139,239		
VE2FK	174	57	79,857		
VE1RGB	160	58	72,848		
VE3CX	148	56	69,720		
VE2FXL	110	52	63,492		
VO1HP	248	28	46,760	NA027	
VA2WA	298	35	43,610		
VE3FH	105	46	41,354		
VE3TW	107	42	39,018		
VE6BMX	102	42	35,322		
VE3IAE	144	38	31,198		
VE3AD	60	34	24,412		
VE1DT	75	31	23,095	NA010	
VE3EJ	89	30	19,380		
VE7JH	209	14	17,010	NA036	
VE9PLS	56	25	14,175		
VA3GKO	42	23	10,603		
VE3DZ	192	16	10,304		
VE9EX	31	23	9,499		
VY2SS	83	16	9,360	NA029	
VE3LJQ	42	19	7,771		
VE2PIJ	47	19	7,714		
VE3FJ	38	18	6,048		
VE2EZD	30	15	4,215		
VE2PDT	20	8	1,568		
VE2SG	14	8	1,056		
VE9BWK	18	7	889		
VE9OA	13	6	624		
VA3IK	28	4	536		
VE7RSV/P	19	3	405	NA091	
VE1RAR	10	3	177		
VE2QV	10	3	177		

YO DX HF CONTEST					
Call	QSO	Mult	Score	Category	
VA3AR	257	85	69,190	SO-AB-CW-HP	
VE1RGB	188	77	49,049	SO-AB-CW-LP	
VE1DT	100	65	28,275	SO-AB-CW-HP	
VE9BWK	37	20	2,800	SO-AB-CW-LP	
VE7IO	38	14	1,204	SO-AB-CW-HP	
VA2AAB	18	12	888	SO-SB-MX-20	

AUGUST NORTH AMERICAN QSO PARTY, SSB

Call	QSO	Mult	Score	Category
VE3CX	777	186	144,522	SOLP
VA3GKO	413	112	46,256	SOLP
VA3MW	329	108	35,532	SOLP
VE6UM	304	82	24,928	SOLP
VE3NB	251	96	24,096	SOLP
VE4YU	233	95	22,135	SOLP
VE7CV	206	91	18,746	SOLP
VE8GER	261	66	17,226	SOLP
VE3DZ	222	76	16,872	SOLP
VE7BC	267	62	16,554	SOLP
VA3TIC	236	64	15,104	SOLP
VA3WR	116	55	6,380	SOQRP
VE2PDT	90	48	4,320	SOLP
VA7AM	93	40	3,720	SOLP
VA3AH	91	38	3,458	SOLP
VE3EJ	76	41	3,116	SOLP
VE3MGY	92	32	2,944	SOLP
VE3UTT	73	33	2,409	SOLP
VE7BGP	51	30	1,530	SOLP
VA7AQD	37	27	999	SOLP
VE3OJN	38	23	874	SOLP
VE3KJQ	27	17	459	SOQRP
VA3EEB	31	14	434	SOLP
VA7HZ	24	18	432	SOLP
VE9AA	20	12	240	SOQRP
VE3TU	18	12	216	SOLP
VA3RKM	14	13	182	SOLP
VE5DL	11	8	88	SOQRP
VE3EDX	6	6	36	SOLP
VE5DMN	2	2	4	SOLP

AUGUST NORTH AMERICAN QSO PARTY, CW

Call	QSO	Mult	Score	Class
VE3JM	1039	211	219,229	SOLP
VE3DZ	921	227	209,067	SOLP
VE3EJ	886	221	195,806	SOLP
VE3KI	716	170	121,720	SOLP
VE3XB	707	167	118,069	SOLP
VE3TA	471	155	73,005	SOLP
VE4EA	499	141	70,359	SOLP
VE3UTT	481	143	68,783	SOLP
VA3EC	562	122	68,564	SOLP
VE1RGB	478	134	64,052	SOLP
VE4YU	364	152	55,328	SOLP
VA7ST	412	129	53,148	SOLP
VE7IO	351	118	41,418	SOLP
VE3EY	370	111	41,070	SOLP
VA2WA	327	111	36,297	SOLP
VE3IAE	319	99	31,581	SOLP
VE9AA	306	100	30,600	SOLP
VE3HG	259	107	27,713	SOLP
VE7CV	253	104	26,312	SOLP
VE3GFN	298	87	25,926	SOLP
CF3NAVY	227	106	24,062	SOLP
VE3JI	226	106	23,956	SOLP
VE2BWL	276	86	23,736	SOLP
*VE3XD	212	73	15,476	SOLP
VA3ATT	199	77	15,323	SOLP
VE4VT(VE4EAR)	155	95	14,725	SOLP
VE2FU	188	76	14,288	SOLP
VY2SS	190	60	11,400	SOLP
VE3VV	142	74	10,508	SOLP
VE1DT	136	51	6,936	SOLP
VE3CX	103	64	6,592	SOLP
K2NV/VE3	106	56	5,936	SOLP
VE3FJ	109	37	4,033	SOLP
VE3DTI	80	43	3,440	SOQRP
VE7BGP	61	40	2,440	SOLP
VE3LMM	63	37	2,331	SOLP
VE2QV	58	33	1,914	SOLP
VA3WR	29	26	754	SOQRP
VA3RKM	35	19	665	SOQRP
VA3IK	27	21	567	SOLP
VA3GUY	31	13	403	SOLP
VE9OA	13	8	104	SOLP

SCC RTTY CHAMPIONSHIP

Call	QSO	Mult	Score	Class
VE5MX	312	107	77,682	HP
VE3UTT	222	107	65,163	HP
VE2EBK	232	106	59,572	HP
VE3FH	183	108	47,304	LP
VE2FK	197	98	46,354	HP
VA7ST	142	76	22,116	LP
VE3AJ	119	75	21,825	LP
VE3IAE	99	71	16,898	LP
CF3NAVY	80	66	12,804	LP
VE4EA	73	44	7,392	HP
VE2FU	51	39	4,953	LP
VA7AQD	43	36	3,600	LP
VA7JC	48	32	3,264	20
VE7HBS	43	30	2,580	HP
VE3FJ	30	25	2,100	15
VE4VT	25	23	1,311	LP
VE7BGP	22	18	882	LP
VE9BWK	15	15	555	40
VA7AM	11	10	230	LP

HAWAII QSO PARTY

Call	QSO	Mult	Score	Class
VE5KS	32	29	2,436	Mixed LP
VE4VT	25	22	1,298	Mixed LP
VE7CV	23	21	1,113	Mixed LP
VE7BC	21	18	846	Mixed LP
VA7KO	13	13	832	Mixed LP
VE3NLS	20	15	645	Mixed HP
VE3SQT	21	15	450	Mixed HP
VE6UM	14	12	360	Mixed LP
VE7RSV	15	15	330	Mixed LP
VE4EA	9	9	153	Mixed HP
VA7BWG	6	5	110	CW LP
VO1KVT	4	4	32	Mixed HP
VE8GER	4	3	12	Mixed LP
VA3RKM	1	1	2	QRP
VE3KJQ	1	1	2	QRP
VA7AQD	2	1	2	Mixed LP
VA3GKO	1	1	1	Mixed LP

NAQCC JULY SPRINT

Call	QSO	Mult	Score	Power	80-40-20 Antenna
VE2TH	42	22	3,608	5W QRP	Inv Vee @32'
VE3DVC	13	11	572	5W QRP	Inv Vee @40'
VE5BCS	12	9	414	5W QRP	Loop ant 25' in trees
VE3FUJ	6	6	144	5W QRP	G5RV @50'
VA3KOT	4	4	64	5W QRP	OCF dpl @30'
VE3RCN	1	1	4	5W QRP	Ground Mounted Vertical

NAQCC AUGUST SPRINT

Call	QSO	Mult	Score	Power	80-40-20 Antenna
VE3DVC	14	12	672	5W QRP	Inv Vee @ 40 ft
VE3EDX	12	7	336	5W QRP	Gnd mtd vertical
VE3FMW	6	5	120	5W QRP	OCF ZEPP @ 40 ft
VE5BCS	5	4	80	5W QRP	Loop ant 30ft

OHIO QSO PARTY

Call	QSO	Mult	Score	Class
VE1RGB	92	42	7,728	SOLP
VA3GKO	82	40	3,240	SOLP
VE3HED	57	37	2,109	SOHP
VE3PYJ	28	22	1,232	SOLP
VA3NGE	37	29	1,073	SOLP
VE6UM	22	16	672	SOHP
VA3RKM	15	8	240	SOQRP
VE2PIJ	2	2	4	SOLP

CONTEST CALENDAR FOR JULY, AUGUST AND EARLY SEPTEMBER 2015

Contest Name	Start	End	Web Address
Canada Day Contest	0000z July 1	2359z July 1	http://wp.rac.ca/2015-canada-day-contest/
DL-DX RTTY Contest	1100z July 4	1059z July 5	http://drcg.de/index.php?lang=en
Venezuelan Independence Day	0000z July 4	2359z July 5	http://www.radioclubvenezolano.org/rules.htm
FISTS Slow Speed Summer Sprint CW	2000z July 4	2400z July 4	http://www.fists.org/operating.html#sprints
FISTS Summer Sprint CW	2000z July 11	2400z July 11	http://www.fists.org/operating.html#sprints
IARU HF World Championship	1200z July 11	1200z July 12	http://www.arrl.org/iaru-hf-championship
NAQCC Sprint	0130z July 16	0330z July 16	http://naqcc.info/
CQ WW VHF	1800z July 18	2100z July 19	http://www.cqww-vhf.com/
NA QSO Party RTTY	1800z July 19	0600z July 19	http://www.ncjweb.com/
RSGB IOTA Contest	1200z July 25	1200z July 26	http://www.rsgbcc.org/hf/rules/2015/riota.shtml
TARA Grid Dip Digital Contest	0000z Aug 3	2400z Aug 3	http://www.n2ty.org/seasons/tara_grid_rules.html
10-10 Int. Summer SSB	0001z Aug 1	2400z Aug 2	http://www.ten-ten.org/
ARRL UHF Contest	1800z Aug 1	1800z Aug 2	http://www.arrl.org/august-uhf
NA QSO Party CW	1800z Aug 1	0600z Aug 2	http://www.ncjweb.com/
WAE DX Contest CW	0000z Aug 8	2359z Aug 9	http://www.darc.de/referate/dx/contest/waedc/en/
MDC QSO Party	1600z Aug 8	0400z Aug 9	http://mdcqsoparty.w3vpr.org/
MDC QSO Party	1600z Aug 9	2400z Aug 9	http://mdcqsoparty.w3vpr.org/
NAQCC Sprint	0130z Aug 12	0330z Aug 12	http://naqcc.info/
SARTG WW RTTY	0000z Aug 15	1600z Aug 16	http://www.sartg.com/contest/wwrules.htm
ARRL 10 GHz Cumulative	0600 Aug 15 *	2400 Aug 16 *	http://www.arrl.org/10-ghz-up
Russian Districts Contest	0800z Aug 15	0800z Aug 16	http://rdaward.org/indexeng.htm
NA QSO Party SSB	1800z Aug 15	0600z Aug 16	http://www.ncjweb.com/
Kansas QSO Party	1400z Aug 22	0200z Aug 23	http://www.ksqsoparty.org/
Kansas QSO Party	1400z Aug 23	2000z Aug 23	http://www.ksqsoparty.org/
Hawaii QSO Party	0400z Aug 22	0400z Aug 23	http://www.karc.net/
Ohio QSO Party	1600z Aug 22	0400z Aug 23	http://www.ohqp.org/
SCC RTTY Championship	1200z Aug 29	1159z Aug 30	http://lea.hamradio.si/scc/rtty/rtty.htm
YO DX HF Contest	1200z Aug 29	1200z Aug 30	http://www.radioamator.ro/contest/
Russian "Radio" RTTY WW Contest	0000z Sept 5	2359z Sept 5	http://www.qrz.ru/contest/detail/93
All Asia SSB Contest	0000z Sept 5	2400z Sept 6	http://www.jarl.or.jp/English/0-2.htm
Tennessee QSO Party	1800z Sept 6	0300z Sept 7	http://tnqp.org/
MI Labour Day QRP Sprint	2300z Sept 7	0300z Sept 8	http://www.qsl.net/miqrclub/

Note: in the above chart an * indicates local time

C4HQ: Cyprus Headquarters (HQ) team to participate in IARU HF World Championship Contest (July 11-12)

Several contest stations across Cyprus will hit the airwaves on Saturday, July 11 starting at 1200 UTC using the special contest call C4HQ. There will be stations on all six HF contest bands (10-160m) on both CW and SSB. Please look out for us! Our contest exchange will be our signal report followed by 'CARS' the official IARU abbreviation of the Cyprus Amateur Radio Society.

This is our third entry in the contest with an HQ station and for the first time we will be making several awards available to stations that will work us on several band/mode slots, with a minimum of six contacts on different band/modes required to secure an award. We are also offering sprint awards to stations that are able to contact C4HQ on the highest number of band/mode slots in the shortest period of time! All awards will be offered to eligible stations free of charge.

For more information about our C4HQ entry in the IARU HF World Championship, including station locations, pictures of operating sites, award program details, QSL policy, etc. please visit the website of the Cyprus Amateur Radio Society at www.cyhams.org. See you in the contest!

THE DEFENCE OF AMATEUR RADIO FUND

The Defence of Amateur Radio Fund (DARF) is a Trust Fund that was established in the early 1990s by the Canadian Radio Relay League to provide financial support for research, and to defray travel expenses of a delegate to World Radio Conferences to defend the Amateur Radio bands.



It costs a lot to attend a WRC meeting such as the upcoming WRC-15 meeting this November (see page 17). Travel and meeting expenses for a three- to four-week conference can top \$10,000 or more in an international city like Geneva, Switzerland even for the most frugal. Without new donations, DARF funds on hand won't last indefinitely.

Donations may be made by cheque only. Cheques should be made out to "The Defence of Amateur Radio Fund" and may be sent by mail to: "Defence of Amateur Radio Fund", 720 Belfast Road, Suite 217, Ottawa K1G 0Z5

For more information please visit darf.rac.ca.

SECTION NEWS THE RAC FIELD ORGANIZATION FORUM

BRITISH COLUMBIA/YUKON:

SM Acting Bill Gipps, VE7XS
A/SM Ron McFadyen, VY1RM
A/SM Neil King, VA7DX
STM Al Ross, VE7WJ
SEC Acting Al Munnik, VA7MP
SEC Terry Maher, VYIAK (Yukon)
OBM Bill Foster, VE7WWW
OOC: Dennis Wight, VE7IJJ
ACC: Karla Wakefield, VA7KJW
Website: www.va7mpg.ca

MARCH-APRIL SM REPORT:

The Simulated Emergency Test (SET) summary report follows. The SET exercise was initially cancelled because the key organizers had to withdraw for personal reasons. Several individuals stepped up and, leveraging the initial work done, prepared a SET exercise for November 22, 2014 starting at 9 am and to be completed by noon.

The intent was to simulate a widespread communication exercise throughout BC and the Yukon. The main communication hub was the South-West Provincial-Regional Emergency Operation Centre (PREOC). We thank them for allowing us the use of their facilities. We had a number of HF bands covered, as well as VHF. We also used voice, CW and Pactor.

Primary lessons learned:

- 1) We should have come up on 80 metres voice first, instead of CW.
- 2) More pre-prepared messages available to all
- 3) More structure to who and how the messages were sent
- 4) If we are going to run multiple modes / multiple bands, we need to have a net control operator on each band / mode from the start of the exercise.

I want to thank all of you who were able to prepare the SET and / or participate in the exercise.

We will leverage our learnings from this last one and do a bigger and better exercise later this year.

– Bill Gipps, VE7XS

Public Service Honour Roll

March:

VE7XLH: 130; VE7DWG: 78;
VE7RB: 69; VA7MPG: 86; VE7GN:
140; VE7WJ: 100

April:

VE7DWG: 90; VE7RB: 73;
VA7MPG: 155; VE7XLH: 120;
VE7GN: 140; VE7WJ: 83

MESSAGE FROM THE RAC CHIEF FIELD SERVICES OFFICER

The past couple of months have been just a bit hectic in this corner of the RAC world! The learning curve has been almost vertical and much has happened – mostly all good.

At the biannual Planning Meeting, which was held in Toronto and attended by the RAC Executive and Board of Directors, direction was given on the reorganization of Field Services.

We will be focused on ARES and how to best support the Section Managers who are the senior RAC representatives in their respective regions of the country.

As this develops you will be kept informed of any significant changes that might have an impact on how your ARES activities may be influenced.

One action that was taken immediately after the Planning Meeting was to hold up the issuing of RAC ARES identification cards until further notice. There were concerns about the wording on these cards that might have liability related issues.

As a consequence of this decision, local/regional RAC ARES groups are encouraged to liaise with your served agencies and have them issue identification cards to you in collaboration with your local RAC ARES team.

The annual Simulated Emergency Test (SET) is fast approaching. This is a great opportunity to test your ability to organize, mobilize and communicate – ideally in collaboration with one or more of your served agencies.



CHIEF FIELD SERVICES OFFICER
Bill Boskwick,
VE4BOZ/VE4IR
PO Box 411
Elm Creek, MB
R0G 0N0
Tel. 204-436-3523
Email: ve4boz@rac.ca

For more information on the SET please see the article on page 50.

Finally, the RAC Annual General Meeting will be held this year in Martensville, Saskatchewan on July 4. If you can, consider attending so you can meet up with other Amateurs from the region and beyond.

As always, I encourage you to send me any questions you may have. I'm here to assist and do what I can to help.

MANITOBA:

SM: Jan Schippers, VE4JS
STM: Jan Schippers, VE4JS
SEC: Vacant
DECs: Jeff Dovyak, VE4MBQ (Capital Region and CANWARN); Gord Snarr, VE4GLS (South-East Central Region / South-West Region); Wayne Warren, VE4WR (North Region and Special Projects); Vacant (North-Eastern Region); Vacant (North-West Region).
ECs: Ron Willisroft, VE4QE (Selkirk and District); Bill Boskwick, VE4BOZ (RM of Grey, RM of Dufferin & Town of Carman); Jason Coombe, VE4JYC, (Brokenhead ARES)

MARCH-APRIL SM REPORT:

Spring and summer are always busy for Amateur Radio. Fortunately, there was no threat of floods this year, and let's hope that Mother Nature is kind and doesn't give us too many storms.

The 2015 Winnipeg ARC (WARC) Spring Fleamarket took place on April 12 at the Heritage Victoria Community Centre. The fleamarket began at 9:30, with coffee, muffins, soft drinks and visiting amongst the attendees. Tables were set up and the anxious buyers were allowed into the main hall just before 10:30.

On April 11, thirteen students began the latest version of WARC's Basic Short Course, which now runs five consecutive Saturdays. The fifth day has the exam in the morning and

Rolf Bandlow's (VE4VZ) practical "How to get started" session in the afternoon.

A note of thanks goes to our chief instructor Dan Perreux, VE4DPR and the support of the Winnipeg ARC, Shaftesbury High School, and all the volunteer instructors for Basic Short Course 9.

Winnipeg ARES Jeff Dovyak, VE4MBQ

Eighteen Winnipeg ARES members and affiliates provided Amateur Radio communications for the Scouts Canada Klondike Derby Event on March 7 and 8 at Camp Amisk. This event was coordinated by Bob Poole, VE4MAQ. Thanks to our volunteers: VA4DFJ and VE4s: JFK, KAZ, FDM, CLK, TTH, HAZ, GMB, TRO, DXR, CIB, GIS, JHJ, KEH, CDM, GWB and MAQ.

Thanks also to Peter, VE4TTH, who towed our Boler trailer out to Camp Amisk and then towed it back.

On March 17, Randy Hull, City of Winnipeg Emergency Preparedness Coordinator, gave a presentation on the Post Disaster Rehabilitation and Recovery Training – Manitoba Mission to the Philippines in September 2014, to a packed Winnipeg ARES General Meeting. One more attendee and we would have been out of chairs!

On Saturday, March 21, 16 Winnipeg ARES members participated in the Winnipeg ARES Exercise-123

which was the Red Cross Congregate Shelter Exercise/ Demo at Immanuel Christian School. ARES participants were VA4PNO and VE4s: BN, HQ, CLK, VD, JAH, KAZ, STL, XYL, SE, GWN, YYL, GIS, DJS, SIG and MBQ.

We are often tasked during City of Winnipeg Flood Operations to establish a temporary Amateur Radio Station at a Reception Centre to provide an Amateur Radio link back to the City of Winnipeg Emergency Operations Centre VE4EOC. So far we have not been tasked to set up a temporary station at a Congregate Shelter so this demonstration was very good learning for us.

Forty-four people attended CANWARN Spotter Training in Beausejour on Saturday, March 28. The venue was organized by Jason Coombe, VE4JYC, the new Emergency Coordinator for Brokenhead ARES. A number of us arrived in town early and enjoyed a hearty breakfast and some fellowship at Vickies Snack Bar. The actual training was held at Lee's Village Restaurant; they provided a training space and very reasonable buffet lunch at the completion of Spotter Training. Environment Canada Warning Preparedness Meteorologist, Natalie Hasell, VE4NAT, provided the bulk of the training while Jeff Dovyak, VE4MBQ, spoke on CANWARN Net protocols.

There were 44 participants in total: VA4s: AJG, VMM, RWT, SKY, GD, MAC, PNO and CQD.

VE4s: NAT, VD, GMS, RR, HK, SYM, TRO, XYL, EDE, TG, JYC, TN, TE, GKS, ADS, WZ, HLO, JDH, DPR, GWN, FDM, STS, VID, LDI, DWG, QK, LK, DI, CY, WTZ, DJS, SE, SIG and MBQ.

In addition, Tyler Bushie, Claudette Gabbs and Phil Stairs also participated.

Of the above, 11 were new CANWARN spotters and three were new Weather Spotters. We picked up three new WWO Net Controllers out of this session too.

Winnipeg ARES President and Public Information Officer (PIO) Jim Sutton, VE4SIG has created a closed Facebook group for Winnipeg ARES members. Any interested Winnipeg ARES member should contact Jim or David, VE4DLA, or Allan, VA4AJG, to get access.

Welcome to Brad Burtnick, VE4WTZ, our newest Winnipeg ARES member. Brad is already registered for next month's Winnipeg Emergency Management (WEM) course.

A lot of work went into making the Winnipeg ARES Silent Auction at the WARC Spring Fleamarket a success. Thanks to Craig Martin, VE4CDM, for organizing it; Tom Mills, VE4SE and Ruth Mills, VE4XYL, for acting as Craig's drivers and table help; VE4SIG and VE4GWN for helping me out on the information side; and also to VE4s SYM, TRO, YYL, DLA, PH and PEH. The new vertical ARES banner that Jim, VE4SIG, ordered made its first appearance in Winnipeg, quite eye-catching as was our new display mode. We've gotten away from photos glued onto Corplast and instead are displaying Winnipeg ARES activities via slideshow on our new flat screen monitor. Again thanks to Jim, VE4SIG, for getting that organized.

It takes more than an engaged membership to have a successful fleamarket fundraising operation. Without generous donors we wouldn't have had anything to offer. Thanks to: Boston Pizza Birchwood, Environment Canada, RCAF 17 Wing/RCAF Run, Craftercindy Pillows, Tom Blatch VE4HQ, Gath Blumm, VE4GWB, Susan Collings, VE4SYM, Rob Stegmaier, VE4RST, Jim Sutton, VE4SIG, David Rosner, VE4DAR, Mark Blumm, VE4MAB, Ruth Mills, VE4XYL, Tom Mills, VE4SE and Cary Rubenfeld, VE4EA.

Due to the somewhat extreme wildland fire conditions in southern Manitoba the VE4EMO Team was

on alert for possible activation from April 15 to 19 and seven members provided their availability in case of activation during ALERT-125; thanks to VE4s: SE, DWG, ESX, GWN, SIG, JNF and MBQ.

Jim Sutton, VE4SIG gave us an interesting presentation on NBEMS at our April General Meeting – the demo at the end was unforgettable.

Our meetings are held on the third Tuesday of the month at 7 pm at Sir William Stephenson Library, 765 Keewatin Street.

– Jan Schippers, VE4JS

Traffic Totals

March: 4

April: 2

ONTARIO NORTH:

SM: Al Boyd, VE3AJB

ve3ajb@vianet.ca

STM: Pat Dopson, VE3HZQ

dopsonp@vianet.ca

SEC: Stiig Larsen VE3LXB

slarsen@vianet.ca

OBM: Paul Caccamo, VA3PC

va3pc@ciinet.org

Website: <http://ontario.racares.ca>

MARCH-APRIL SM REPORT:

By the time you read this report Field Day will have come and gone. I know many ARES groups participated and had a very successful operation. Field Day is an exercise that tests the ability of each club or ARES group in setting up emergency communications. In my next report I will have the results on how some of the groups did in the north.

As some of you may know I have agreed to step in as Acting Section Managers for the Ontario South and GTA Sections until new Section Managers have been found. If you have any questions or concerns please feel free to contact me at any time. Again thank you to all of you for your continued support for ARES and RAC.

– Allan Boyd, VE3AJB

Amethyst District

Thunder Bay's Area Nets:

Sunday: Amethyst ARES VHF Net on VE3TBR 146.820- pl 107.2, IRLP Ref. # 9031 @ 0045Z (7:45 pm); Cook County ARES Response Team (CCART) net at 0100Z (8 pm) on the BWARC repeater and Grand Portage repeater - 146.655 with CTCSS 151.4

Monday: SATERN NET on VE3TBR 146.820- pl 107.2 and IRLP Ref. # 9032. SATERN Digital Nets on Monday & Wednesday nights 8 pm- 14.065, 9 pm- 7.065, 10 pm- 3.5835, mode - Olivia 8/500 1000Hz waterfall centre.

Tuesday: 2m LARC ARES Net on VE3YQT 147.060- @ 7 pm ET, and after this net is the new Thunder Bay ARES Digital Net on PSK31 between 1000 & 2000 Waterfall, 145.050 FM mode @ 7:30 pm (usually starts after the 2m ARES net)

Every day: the Northwestern Ontario ARES Net every evening at 8:15 pm (local) on 3.750 MHz (note the time does not change with daylight savings time)

The region was very dry in April due to lack of snow and many small fires have been noted along highways and some northern areas of the Province as well. Rain is very much needed. We can do without thunderstorms as the lightning could cause more trouble than we need.

Some severe weather patterns have been noted already through many of the Upper/Mid States resulting in some tornadoes as well as flooding.

On that note of weather conditions, CANWARN training will be starting up again across the Province and Thunder Bay and area.

Killarney District

Manitoulin Island and North Shore

On April 2, ONN SEC Dave Hayes, VE3JX, met with the Manager of the Gore Bay airport and was able to obtain permission for the Manitoulin ARES group to conduct their annual Field Day exercises from that location.

On Thursday April 9, Al Boyd, VE3AJB and Jim McLean, VE3LJM, attended the Emergency Management Committee meeting in Espanola and gave a presentation on ARES communications and how they can utilize inter-agency interoperability while still maintaining the integrity of their own systems.

The Manitoulin ARC held a Basic radio course in April and there are 28 people awaiting their new call signs at the time of writing this report. Congratulations to all!

Sudbury

Monthly meetings have been reduced in frequency. Recruitment planning is underway.

DECs reporting:

VA3s: PC

VE3s: FAL, JX and LBX

ECs reporting:

VA3s: AJV, SPT

VE3s: EGC, LJM, OTL, MXJ, SUT

Official Bulletin Stations

Brad Rodriguez, VE3RHJ, OBM

November-December 2014

(ONS, ONE, GTA):

VE3GIO, VE3IQZ, VE3JUZ, VE3KII,

VE3SHM and VE3VBR

ONTARIO EAST:

SM: Michael Hickey, VE3IPC

Email: ve3ipc@gmail.com

SEC: Vacant

STM: Vacant

OBM: Vacant

Website: <http://ontario.racares.ca>

MARCH-APRIL SM REPORT:

On April 15, I attended the Section Managers Canada-wide telephone conference that the new Chief Field Services Operations (CFSO) Bill Boskwick, VE4BOZ, initiated. We exchanged introductions and discussed a number of issues that need attention and support.

The Rideau Lakes Amateur Radio Club hosted the Smiths Falls Ontario Hamfest on May 9. The new RAC Director for the Ontario North/East Region, Glenn MacDonnell, VE3XRA and I managed the RAC table and we were kept busy most of the time. It was very good to see old friends and to meet some of the new friends I had met in the past year over the airwaves.

Glenn and I rotated shifts to work the floor and chat with some more friends who had not yet stopped by the RAC table. We gave away many recent issues of TCA magazine – even a few copies we had on hand of the latest issue – and Glenn sold a few items.

Glenn brought with him many samples of shirts and other printed items for show. I bought a neat ARES licence plate add-on for my rear licence plate for display.

I managed to buy some much needed antenna wire from Bob Morton of Maple Leaf Communications to improve my current ad hock HF station antenna I had set up during the winter. From another table I also bought a used short Hustler MO-4 folding mast for mobile HF, which may come in handy.

Now that winter and spring season is well over, many Clubs and ARES groups activities no doubt are on the planning board for the summer, but Field Day 2015 is the main event at hand for many groups. I expect the next TCA issue will have many reports from Field Day 2015 from many parts within the Section. I will acknowledge all Field Day messages coming from the field over the air and relayed to me by email or by other means, which are worth extra points to your event.

Eastern Ontario ARES District EC report – Lance, VA3LP

The Eastern Ontario ARES District is moving into the usual Amateur activities for spring: fixing repeaters and getting outdoors. It is time to

get out the ARES playbooks and do some needed exercising of the groups.

In April the District groups have mainly been planning for upcoming events in May and June. Early spring brings thoughts of antenna maintenance and Field Day activities. Spring also brings the first of the bike and boat support exercises. Looking forward to a busy spring and summer.

Ottawa ARES/EMRG Group submitted by AEC Mike, VE3FFK

The Ottawa ARES/EMRG Group conducted the usual monthly tests of the repeater and digital systems by Dave, VE3KMV, with the assistance of Bob, VA3QV, Ron, VA3ACZ and Mike, VE3FFK. All repeaters were in working order.

The Lanark Highlands Forest Car Rally and the CN Cycle for CHEO (Children's Hospital of Eastern Ontario) will be held on the same weekend in May. The former involves a few Amateurs from the local area deployed to Lanark County, while the latter requires many Amateurs on bicycles, on foot and in cars deployed throughout much of the urban parts of Ottawa. There will be more about both events in next TCA, but I'm off bright and/or early this morning to the car rally.

Prescott-Russell-ARES Group submitted by GC Lance, VA3LP

The Prescott-Russell (PR)-ARES Group has gained access to their Alfred repeater VA3PRA. Harry, VA3ZAK and Norm, VE3NPL, were instrumental in getting the repeater back on the air. Although some low power stations in the far west end of Prescott-Russell have difficulty getting access to it, it's generally working quite well.

PR-ARES meets at the Chamberland Centre in Rockland on Thursday evenings. We usually have access to Wi-Fi from TV22, a local cable station co-located in the Chamberland Centre, and we use this connection to access data for our meetings and projects. TV22 has changed access to their Wi-Fi and we must submit a formal request. A letter was sent to TV22 Rockland Inc to request Internet access and we are waiting patiently for a reply and access.

Since we no longer have access to the Internet at the Chamberland Centre clubhouse site, some members are bringing in projects to work on. This included working on the Alfred repeater controller by Harry, VE3ZAK. Norm, VA3NPL, built a "Pixie" QRP transceiver. Jim, VA3KV, has also downloaded videos from Ham Radio Now and

Ham Nation for screenings at Triode Thursday meetings.

In April, the meetings were filled with discussions on antenna building, upcoming equipment purchases and plans to go to the Dayton Hamvention as well as the Smith's Falls hamfest. Also, Field Day is just around the corner.

RCE-ARES Group submitted by GC Debra, VE3IEH

On March 10, a team of members of the Renfrew County East (RCE)-ARES Group made a site visit to the Arnprior Fire Department in order to determine why repeater VE3YYX was not functioning. The team consisted of GC Debra, VE3IEH, Graham, VE3AMN, Sandy, VE3AAC, Allen, VE3JGU, Steve, VE3FTS, Wayne, VE3JSQ, and Rick, VA3RWH.

The UHF repeater VE3YYX equipment is on a table in a small room that is also used for firefighter training (several people in a completely dark smoke-filled space). The room is located on the top floor of the Arnprior Fire Department. The antenna was tested and it is fine and the coax and connectors are in good condition. The repeater was examined and tested and several loose connections were observed and corrected. During testing it was noted that the duplexer was intermittent. A temporary fix was made by adjusting its angle ever so slightly, but that needs further examination. Wires were wiggled and a couple of those connections were made more firm. All in all, the repeater is up and running albeit with the ongoing intermittent problem. A few local Arnprior group members will continue to monitor the repeater.

During that time we met with the Arnprior Fire Chief. It was proposed that a shelf be installed high on the wall to house the repeater in order to avoid interference from bodies moving around during training. The lack of backup power was mentioned and the Chief is prepared to have an electrician add the repeater to the generator. The Chief was supplied with an overview document about ARES. He is prepared to report to his superiors on the repair success and to discuss with them how to proceed (to do more complex testing and preferably to remove the repeater to a bench to perform a few repairs).

The Renfrew County East (RCE)-ARES Group and the Champlain Regional Repeater Association (CRRRA) groups met for breakfast with members of the Almonte ARC in Arnprior on the April 15. There

RAC FIELD ORGANIZATION REPORTS

National Traffic System (NTS) Net Reports

Net (Manager)	Sessions	QNI	QTC
March 2015:			
BCEN (VE7XLH)	31	234	25
BCYTN (VE7WJ)	31	458	81
Laurentian	31	461	0
MEPN (VE4JS)	31	753	2
MMWXN (VA4GD)	31	486	1
MRS (VE4HK)	9	285	0
MSMN (VE4AEW)	22	547	0
OPN (VE3XRC)	31	36	0
April 2015:			
BCEN (VE7XLH)	30	220	25
BCYTN (VE7WJ)	30	439	27
Laurentian	30	455	30
MEPN (VE4JS)	29	599	1
MMWXN (VA4GD)	30	471	1
MRS (VE4HK)	9	228	0
MSMN (VE4AEW)	22	561	0
OPN (VE3XRC)	30	36	1

were 18 people present who enjoyed the fare served at PJs Restaurant and the lively conversation. Although the groups only meet two or three times a year, it is always an enjoyable time as we share common practices and fellowship.

After breakfast, a small team consisting of GC Debra, VE3IEH, Graham, VE3AMN, Rob, VE3JA and Rick, VA3RWH, attended at the Arnprior Fire Department where repeater VE3YYX was removed for intensive testing and diagnosis of a plaguing intermittent problem. A 2m transceiver was also removed in order for it to be tested and set up as an alternate system to be re-installed at the Fire Department. The suspect duplexer was confirmed as the source of the problem by Sandy, VE3AAC, (Technical Director to the CRRRA) and he will be exploring either a repair or a replacement at the earliest possible opportunity.

RCW-ARES Group submitted by GC Bob, VE3YX

The Renfrew County West (RCW)-ARES Group held five Wednesday evening nets this month. All of the RCW-ARES laptops have been updated with the latest Version 3.0 of Outpost.

We will be participating in a Nuclear Emergency Plan exercise on May 20. This exercise will only be exercising the Municipal Emergency Operations Centre (MEOC), the Joint Traffic Control Centre (JTCC) and the Emergency Workers Centre.

We will have stations set up in the EOC, the JTCC and the Red Cross in Pembroke. There is no foreseen

need for ARES communications for the Emergency Workers Centre. We will be using 2m voice and packet with Outpost. If required, we might also use Winlink/Winmor on HF for long distances such as to the Provincial Emergency Operations Centre (PEOC) in Toronto.

SD&G ARES Group submitted by GC Earle, VE3IMP

The Stormont Dundas & Glengarry (SD&G)-ARES Group continues to read ARES bulletins each Monday, at 7 pm local, on the club's 2m net conducted on VE3SVC (147.180 MHz+). Amateurs are also asked to then check in on the VE3MTA (UHF) repeater.

Occasionally, we also call for checkins on a new ARES repeater located in Cornwall (VE3VSW) and VE3SVR in Morrisburg. This process confirms the serviceability of nearby SVARC repeater systems at least once a week should they be required by SD&G ARES.

The Seaway Valley Amateur Radio Club (SVARC), where most ARES members come from, held its last meeting on March 25. Aside from the bulletins and club meeting things have been very quiet on the SD&G ARES front.

Districts reporting: Eastern Ontario ECs (GCs) or Assistants reporting:

VE3IMP, VE3FFK, VE3YX, VE3IEH and VA3LP

DECs reporting: VA3LP

OBS reporting: VE3YX, VE3KII, VE3VY, VE3ZJS and VE3IQZ

– 73, Michael Hickey, VE3IPC



COMING EVENTS

THE HAMFEST AND FLEAMARKET CALENDAR

The following events are listed by date. Some dates and details are tentative. For more Hamfests and Fleamarkets please go to <http://rac.eton.ca/events/upcoming.php>

52ND INTERNATIONAL HAMFEST

Date: Saturday, July 11.

Place: US Lodge in the International Peace Garden; south of Brandon on the Canada-US border.

Description: Fleamarket. Rabbit Hunts. Prizes. Mobile Judging. Food Concession. Homebrew Contest. Saturday night Dance. Free Saturday lunch for those registered. Campers please identify yourself at the gate for special camping rates.

Cost: Registration fee is \$15 per person.

Info: Contact Richard Holder, VE4QK, at ve4ihf@mts.net or 204-268-1702.

Web: www.mts.net/~holderr/ihf.htm

ONTARIO HAMFEST 41st ANNIVERSARY

Sponsor: Burlington Amateur Radio Club
Date: Saturday, July 11.

Time: Inside & Commercial Vendors: 7 am at the Robert St Gate; Tailgate Vendors: 8 am at the Robert St Gate; Public: 9 am at the Thomas Street Gate only.

Place: Milton, Ontario; the entrance to the General Admission parking is just opposite the JM Denyes Public School, 215 Thomas Street.

Description: Special Guest Greg Jurens, K5GJ, Vice-President Sales & Business Development at FlexRadio Systems, courtesy of Radioworld.

Cost: General Admission \$7.

Tables: \$14 each; Tailgate Permit: \$7 per space.

Talkin: 146.520 Simplex – Ontario Hamfest

Info: Contact Hamfest Chairman: Bryce Lee, VA3TRN at ontariohamfest@barc.ca. For Vendor Registration Forms and Hamfest Flyers contact Vendor Coordinator: Norm Freidin, VE3CZI at ontariohamfesttables@barc.ca

Web: <http://ontariohamfest.ca>

7TH ANNUAL JUNK-IN-THE-TRUNK EVENT

Date: Saturday, August 22.

Time: 7:30 am until 12 noon.

Place: Newmarket, Ontario; in the paved parking lot of the Newmarket Theatre at 505 Pickering Crescent near Leslie Street and Mulock Drive.

Description: Junk in the Trunk outdoor Amateur Radio Garage Sale Hamfest. Bring any or all of your surplus radio related items. Great Venue. Rain or Shine. Over 45 vendors attended last year!

Cost: Free admission; Vendors \$5 per space per car and additional spaces \$5. All money is donated to the Newmarket Theatre group.

Talkin: 146.520 local repeater is 147.225.

Info: Nick, VE3NJG, at nickve3njg@rogers.com or Mike, VE3MKX at mkx@bell.net.

VHARA SWAP MEET

Sponsor: Victoria-Haliburton Amateur Radio Association

Date: Saturday, August 29.

Time: Vendors 7 am; Public 8 am to 11 am.

Place: Lindsay, Ontario; Masonic Temple at 10 Ridout Street (Mill Street Entrance).

Description: Maple Leaf Communications will be one of the Vendors at the Swap Meet. Lots of free parking. Refreshments and food will be available.

Cost: Free admission; Vendors: 6-foot Indoor Vendor Space \$7. (You must bring your own table and chairs) Outdoor Tailgate Space \$5. (Price is for floor space only!) Registration at the Door.

Talkin: VE3LNZ Repeater 147.195 MHz +.

Info: Contact Glen Glisinski, VA3GTH, at glenglisinski@gmail.com or 647-498-4231.

Web: <http://www.vhara.ca>

VANCOUVER ISLAND HAM HAPPENINGS

Sponsor: Cowichan Valley Amateur Radio Society

Date: Sunday, August 30.

Time: Vendors: 8 am; Public: 9 am to 12 noon.

Place: Duncan, British Columbia; Island Savings Centre, 2687 James Street.
Description: The largest Amateur Radio fleamarket on Vancouver Island. Door prize. Raffle prizes. 50/50. Commercial Vendors. Plenty of free parking / tailgating.

Concession will be open, fast food restaurants next door. Plenty of room for mingling.

Cost: Entry is \$5 and includes a door prize ticket. Tables are \$20 and include one entry.

Talkin: Mt. Sicker Repeater, 145.470 (Tone: 127.3).

Info: For tables and other information contact Gabor Horvath, ve7jh@rac.ca or call 250 715-8634.

Web: <http://www.cvras.com>

OTTAWA (CARP) 18TH ANNUAL HAMFEST

Sponsor: Ottawa Amateur Radio Club, Inc.
Date: Saturday, September 12.

Time: Vendors 7:30 am; Tailgaters: 8 am. Indoor Fleamarket open: 9 am to noon.

Place: Ottawa (Carp), Ontario; at the Carp Agricultural Fairgrounds, 3832 Carp Road (in the W. Erskine Johnston Arena at the north end of the fairgrounds).

Description: The region's largest fleamarket and hamfest. All of the big Ham Radio retailers are going to be there! Major door prize draws! Breakfast, coffee, and lunch concession. Volunteer organizations and displays. Onsite Amateur Radio licence exams. Get your licence, or upgrade during the hamfest! Note: if you are upgrading, bring the 11-digit certificate number on your licence to speed processing.



Maple Leaf
Communications

Since  1989

<http://www.mapleleafcom.com>

- VHF & UHF Mobile & Base Antennas
- HF Monoband Vertical Antennas
- HF Multiband Dipoles (G5RV types)
- 70' 40/80m Dualband Dipole (no traps)
- 39' 40/20m Dualband Dipole (no traps)
- 6m Yagis (3 & 4-element) & Verticals
- Portable J-Pole Antennas (6m/2m/70cm)
- Zeus Lightning Surge Suppressors
- RF Connectors & Adapters
- Coaxial Cables (50, 75, 93, 125, & 36 Ohm)
- Ladder Line (300, 440, & 450 Ohm)
- Antenna Wire (bare, tinned, & insulated)
- Baluns 1:1, 4:1, 6:1 (stainless hardware)
- RF Coaxial Chokes (160m thru 6m)
- Fiberglass Rods & Tubes
- Dacron Rope (3/32" to 5/16" dia.)
- Aluminum tubing (telescopic)
- Custom Antennas
- Duplexers for 70cm and 23cm

Box 1471, Everett, ON L0M 1J0
Tel: (705) 435-2819
Fax: (705) 435-2996



email: info@mapleleafcom.com

Cost: Public \$6; Tables \$14 plus admission, \$5/tailgate (plus admission).

Talkin: VE2CRA, 146.94-, 100 Hz.

Info: Ed Sich, VE3WGO, phone or text msg to: 613-853-2281, fleamarket at oarc.net or see the ad on page 27.

Web: <http://www.oarc.net/fleamarket>

LONDON ARC 38TH ANNUAL HAMFEST

Sponsor: London Amateur Radio Club Inc.
Date: Sunday, September 20.

Time: 9 am to 12 noon.

Place: London, Ontario; Hellenic Community Centre, 133 Southdale Road West.

Description: Sale of new and used radios, etc. Free parking, Coffee and muffins for small fee. Commercial Dealers and wheelchair access.

Cost: Admission \$8; Tables \$15 first one; \$10 for each extra table.

Talkin: VA3LON, 147,060 PL 114.8

Info: Contact larchamfest@gmail.com

Web: <http://www.larc.ca>



HARC HAMFEST 2015

Sponsor: Hamilton Amateur Radio Club

Date: Saturday, October 3.

Time: Public 9 am; Vendors 7 am.

Place: Ancaster, Ontario; Ancaster Fair Grounds in the School Fair Building, 630 Trinity Road.

Description: An Amateur Radio, computer, and electronics fleamarket. Parking and Mobile food truck onsite.

Cost: Public \$7; Tables \$12 each.

Mail payment to: The Hamilton Amateur Radio Club, 117-350 King Street East, PO Box 75073, Hamilton, Ontario L8N 4G6. Tables are reserved upon receipt of payment on a first come basis. Please book in advance to avoid disappointment.

Talkin: 146.76 (-) with tone 131.8 VE3NCF

Info: General info: Paul Fleck, VE3HTF ve3htf@hamiltonarc.ca or 289-431-1030

Vendor liaison: Mardy Eedson, VE3QEE

ve3qee@hamiltonarc.ca or 905-648-0187

Web: <http://www.hamiltonarc.ca>

COMFEST 2015 SWAP MEET

Sponsor: Delta Amateur Radio Society

Date: Sunday, October 4.

Time: Doors open to the public at 10 am.

Place: Delta, British Columbia; Just south of highway 17 and 56th Street in Tsawwassen.

Cost: Public \$5 per person.

Info: Contact gi@deltaamateurradio.com

Web: <http://www.deltaamateurradio.com>

MONTREAL SOUTH SHORE HAMFEST

Sponsor: Club Radio Amateur Rive-Sud de Montréal

Date: Saturday, October 17.

Time: Vendors 6 am; Public 9 am.

Place: Longueuil, Quebec (10 minutes from downtown Montreal); Place Desaulniers, 1023 Taschereau Boulevard.

Description: The biggest Hamfest in Quebec. Restaurant. Free parking. ATM onsite Accessible to handicapped persons.

Cost: Public \$7; Table \$10 (admission not included).

Talkin: 145.390 MHz (-) 103.5 Hz, VE2RSM

Info: Noël Marcil, VE2BR, 450-691-2009 or hamfest@ve2clm.ca

Web: <http://www.ve2clm.ca/articles.php?lng=fr&pg=120>

WINNIPEG ARC FALL FLEAMARKET

Sponsor: Winnipeg Amateur Radio Club

Date: Sunday, October 18.

Time: Coffee, snacks and eyeball QSOs

9:30 am; Vendor setup: 9:45-10:30 am;

Buying begins: 10:30 am; Prize draws

begin: 11:30 am.

Place: Winnipeg, Manitoba; Heritage Victoria Community Club, 950 Sturgeon Road.

Description: #1 Fall social event for old and new hams, and tables filled with exciting bargains.

Cost: Public: \$5 per person, exact change preferred; Tables: \$5 each for WARC members, others \$10 each.

Info: Contact Ruth, VE4XYL, 204-837-6915 or ve4se@mts.net to book your table.

Contact Dick Maguire, VE4HK, at 204-256-3143 or ve4hk@rac.ca for further information.

Talkin: 147.39 MHz positive offset, 127.3 tone.

Web: http://winnipegarc.org/flea_market.html

39TH YORK REGION HAMFEST

Sponsor: York Region Amateur Radio Club

Date: Saturday, October 31.

Time: Vendors: 6:30 am to 8:30 am.

General public is admitted to the indoor gathering area commencing at 7:30 am. No more braving the elements while waiting for the event to open! Have breakfast on site.

Doors open to the vendor areas at 9 am.

Place: Markham, Ontario; 10801 McCowan Road.

Description: Vendors galore in two separate halls, plus a separate hall for admissions and refreshments Free tea and coffee. Breakfast and refreshments are available. Wide aisles for scooters and wheelchairs. Exhibits and demonstrations. Lots of parking. Great door prizes. Grand Prizes. DXCC, WAS & VUCC Card Checking. Licensing Examinations (register with Hamfest Coordinator prior to Hamfest to ensure we bring enough exams.)

Cost: \$7 per person and this includes a door prize ticket – exact change preferred. Children 12 and under admitted free.

Vendor tables are \$33 each for a table 8-feet long. Grand Prize tickets are \$5 each, three for \$10.

PRE-INVENTORY SALE

MFJ Analyzers from \$259

Ainco DJ-V17T 5W Handheld \$129

Ham IV Rotor \$849

Cushcraft A4S Triband \$895

Ham IV & A4S package deal \$1,595

1/8 inch Dacron rope .22 ft 200 feet \$35

TRYLON TOWERS

TITAN TOWERS

Up to 96 feet free standing

Super Titan Towers

Up to 190 feet Self-supporting

CSA compliant

25T Towers

20' – 80' when bracketed

Up to 110 feet when guyed

STG Series

Guyed up to 480 feet

ROHN

ROHN

H.C. MacFarlane Electronics Ltd.

R.R. 2 Battersea, ON KOH 1H0
Call Harold, VE3BPM, or Tom, VE3UXP.
Phone 613-353-2800 Fax 613-353-1294
Email: macfld@kos.net
www.macfarlaneelectronics.on.ca

Talkin: VE3YRA 145.350 MHz (-) T: 103.5 Hz or VE3YRC 147.225 MHz (+) T: 103.5 Hz

Info: Contact yrarc.hamfest@gmail.com

Web: <http://yrarc.org>

MAPLE RIDGE SWAP MEET

Sponsor: Maple Ridge Amateur Radio Club

Date: Sunday, November 1.

Time: Vendors 7:30 am; Public 9 am;

Open for pancake breakfast 8 am.

Place: Pitt Meadows, British Columbia; 12460 Harris Road, 1 Block South of the Lougheed Highway in the old REC Building.

Description: Come one come all! Ham Radio & computer Swapmeet. The largest in the Fraser Valley. Great prices lots of stuff. Pancake breakfast between 8 am and 9 am. Concession will remain open during the event.

Cost: Tables \$20 includes 1 entry and chance to win a radio. Entry \$5 includes chance to win a radio.

Talkin: 146.800 -600 + Tone 156.7

Info: Call Nick at 604 465-9476 or contact ve7te@mrarc.net.

Web: <http://www.mrarc.net>

Note: the deadline for the upcoming issues of TCA are July 15, September 15 and November 15. Please send your submissions to tcamag@yahoo.ca

CZ2F: 50TH ANNIVERSARY OF THE CANADIAN MAPLE LEAF FLAG

CZ2F will be special event station, sponsored by Robert Emerson, VE3RHE, which will operate from Grid FN76vs (IOTA NA-029) to celebrate the 50th Anniversary of the Canadian Maple Leaf Flag.

The event will begin on Wednesday, August 19 at 1500 UTC and end on Monday, August 24 at 1500 UTC. This will be a paper operation.

Frequencies: HF bands (40m to 10m) with a focus on 12m and 17m

QSL via VE3RHE (Direct or Bureau). Send QSL request and SASE (or one green stamp for USA, three green stamps for International) to: Robert Emerson, 6950 Summer Heights Drive, Mississauga, Ontario, Canada L5N 7E9

For more information please contact Robert at ve3rhe@rac.ca or visit the Canada 150th website at <http://www.canada-150th.ca>



**SPECIAL
DEAL FOR
RAC
MEMBERS**



10% OFF BOOKS at the *RSGB* *Bookshop*

Simply insert
the following code:

RACdiscount

(Excludes Postage)



***Get great books delivered
to your door, and benefit
the RAC in the process***



Radio Society of Great Britain www.rsgbshop.org

3 Abbey Court, Priory Business Park, Bedford, MK44 3WH. Tel: 01234 832 700 Fax: 01234 831 496

Radioworld

4335 Steeles Ave. West, Toronto, ON M3N 1V7

Phone 416-667-1000 Fax 416-667-9995

email: sales@radioworld.ca

Authorized
Dealer

KENWOOD

Factory
Service Centre

Nothing But Performance!

The TS-590S

HF/50 MHz All Mode Transceiver



Kenwood has essentially redefined HF performance with the TS-590S compact HF transceiver. The TS-590S RX section offers "top of the line" IMD (intermodulation distortion) characteristics. Best in class dynamic range when handling unwanted, adjacent off-frequency signals.*

- HF-50MHz 100W with Built-in Antenna Tuner
- Advanced DSP from the IF stage forward
- 500Hz and 2.7KHz roofing filters included
- Heavy duty TX section
- 2 Colour LCD



TS-990S



TS-2000



TM-D710A



TS-480HX/480SAT



TM-V71A



TM-281A



TH-D72A TH-K20A TH-F6A

Great Selection | Great Service | Competitive Prices

central Radioworld

8, 711 48th Ave., S.E., Calgary, AB. T2G4X2

Phone 403-239-1400 Fax 403-239-1408

email: sales@radioworldcentral.ca